

Tyre pressure monitoring system (TPMS)

TYRE PRESSURE MONITORING SYSTEM (TPMS)

⚠ TPMS provides a low pressure warning and does not re-inflate your tyres. Tyre pressures should be checked regularly, using an accurate pressure gauge when the tyres are cold.

⚠ TPMS can NOT register damage to a tyre. Regularly check the condition of your tyres, especially if the vehicle is driven off-road.

! When inflating tyres, care should be taken to avoid bending or damaging the TPMS valves. Always make sure of correct alignment of the inflation head to the valve stem.

! To avoid damage to TPMS valves, it is recommended not to use rigid tyre inflation wands. This is to avoid the risk of excess leverage and sideways pressure on the valve.

Note: Non-approved accessories may interfere with the system. If this occurs, **TYRE PRESSURE MONITORING FAULT** is displayed in the Message centre.

Note: Different types of tyre may affect TPMS performance. Always replace tyres in accordance with recommendations.

TPMS constantly monitors the tyre pressure in each wheel, including the full size spare. Temporary-use spare tyres are not monitored.

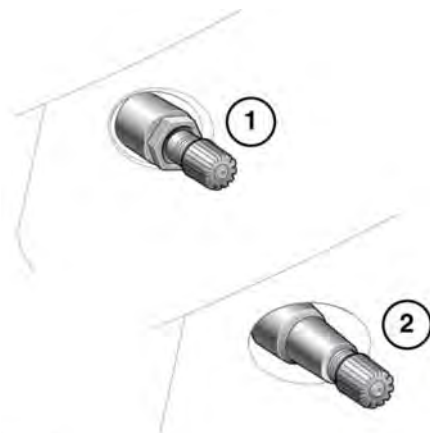

Wheels fitted with TPMS can be visually identified by the external metal lock nut and valve (1). All Land Rover non-TPMS wheels have a rubber valve fitted (2).

Note: At each tyre change, a special service kit is required for each TPMS valve.

Tyre pressures should be checked regularly when the tyres are cold, and adjusted as necessary. The presence of TPMS does not remove the need to check tyre pressures as part of a vehicle safety check.

The tyre pressure warning lamp (see **61, TYRE PRESSURE MONITORING SYSTEM (YELLOW)**) illuminates when one or more of the tyres are significantly under-inflated, accompanied with a message in the Message centre. Stop and check the tyres as soon as possible and inflate them to the recommended pressure for the vehicle's loading condition.