

## HEADLAMP REMOVAL

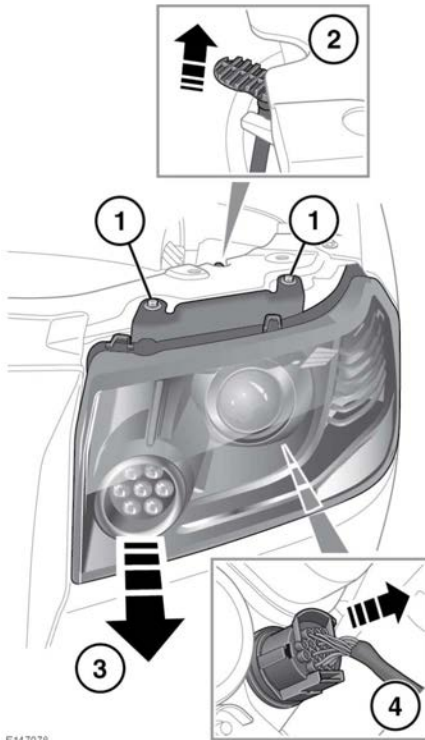

**!** Do not place the removed lamp unit face down on hard or abrasive surfaces. Doing so may scratch the surface of the lens.

1. Undo and remove the 2 retaining bolts.
2. Pull up the locking lever to release the headlamp unit.
3. Pull the headlamp unit forward to allow access to the rear of the unit.
4. Disconnect the electrical connector from the back of the unit, by pressing the tab and pulling the connector.

## HEADLAMP BULB IDENTIFICATION

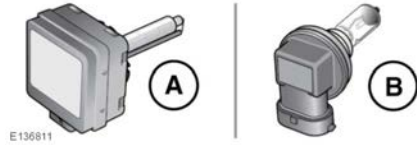

- A. Xenon bulb.
- B. Halogen bulb.

## HALOGEN BULBS

Dependent on vehicle specification, halogen bulbs may be used for high beam, dipped beam, and front fog lamps. Take care not to touch the glass part of the bulb with your fingers; always use a cloth to handle the bulb. If necessary, use methylated spirits to remove finger prints.

## XENON LAMPS

**!** Replacement or maintenance of xenon lamps should only be carried out by suitably qualified personnel.

**!** High voltage is required to ignite the gas and metal vapour which are used to power xenon lamps. Contact with this voltage can cause serious injury.

**!** Xenon lamp units operate at a very high temperature. Make sure the lamp units have cooled before attempting to touch them.



Seek advice about the correct disposal of xenon lamp units from a Dealer/Authorised Repairer, or your local authority.