

Wheel changing

WHEEL CHANGING

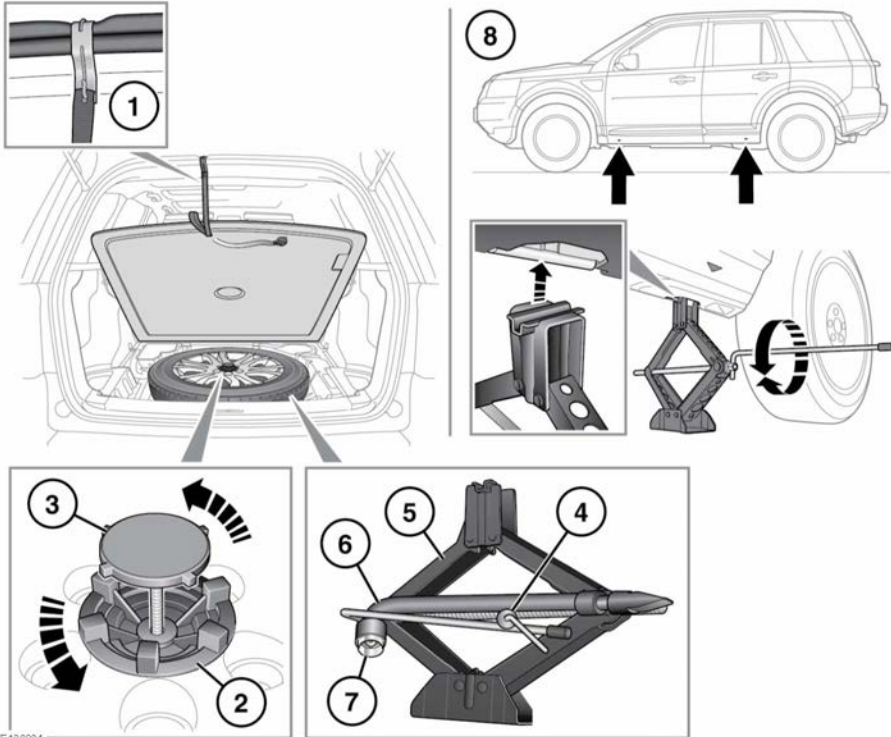

E136834

⚠ The spare wheel is heavy and if handled incorrectly may cause injury. Use extreme caution when lifting or manoeuvring the wheels.

⚠ Always secure the spare wheel, or the removed wheel, in the correct position using the retaining bolt.

⚠ Always remove the spare wheel before jacking the vehicle.

⚠ **WARNING - THAT NO PERSON SHOULD PLACE ANY PORTION OF THEIR BODY UNDER A VEHICLE THAT IS SUPPORTED BY A JACK.**

Note: Before removing the spare wheel, take note of its stowage position. The wheel to be changed must be correctly stowed in its place.

Note: Examine the jack occasionally, clean and grease the moving parts, particularly the screw thread, to prevent corrosion.

1. To access the spare wheel, lift the floor panel and fit the retaining strap hook to the taildoor guttering.
2. Slacken the locking ring by turning anticlockwise.
3. Undo and remove the retaining bolt and then lift out the spare wheel.