





Wheel changing

 If jacking the vehicle on a slight slope is unavoidable, place the chocks on the downhill side of the 2 opposite wheels.

 Take care when lifting the spare wheel, and removing the punctured wheel. The wheels are heavy and can cause injuries if not handled correctly.

 Remove the spare wheel prior to jacking the vehicle, to avoid destabilising the vehicle when raised.

 Take care when loosening the wheel nuts. The wheel brace may slip off if not properly attached, and the wheel nuts may give way suddenly. Either unexpected movement, may cause an injury.

 **WARNING - THAT NO PERSON SHOULD PLACE ANY PORTION OF THEIR BODY UNDER A VEHICLE THAT IS SUPPORTED BY A JACK.**

IMPORTANT – USE OF SPARE TYRE

 Always adhere to the instructions given on the temporary-use spare wheel warning label. Failure to comply can be dangerous.

 The temporary-use spare wheel is **FOR TEMPORARY USE ONLY**. Drive with caution while the temporary spare wheel is fitted. Make sure an original size wheel and tyre are fitted as soon as possible.

 Do not fit more than one temporary spare wheel on the vehicle at any one time.

 Do not exceed 80 km/h (50 mph) while the temporary spare wheel is fitted.

 The tyre pressure in the temporary spare wheel should be 4.2 Bar (60 psi, 420 kPa).

 **DSC must be switched on while the temporary spare wheel is in use.**

 **Traction devices, such as snow chains, cannot be used with a temporary spare wheel.**

LOCKING WHEEL NUTS

Locking wheel nuts can only be removed using the special adaptor provided in the tool kit.

Note: When the vehicle is first supplied, the adaptor may be stored in the glove box. It should be removed and stored in the tool kit as soon as possible.

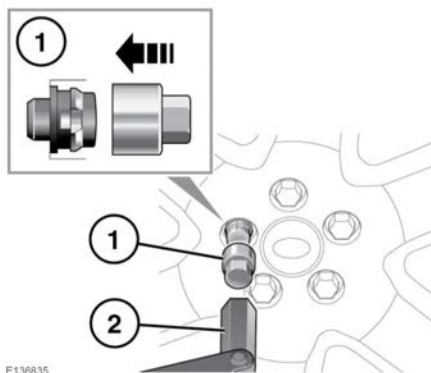

E136835

1. Insert the adaptor into the locking wheel nut, making sure that it is fully engaged.
2. Using the wheel brace, unscrew the wheel nut and adaptor.

Note: A code number is stamped onto the underside of the adaptor. This number must be recorded on the security card supplied with the literature pack. If a replacement adaptor is required, you will be asked to quote this number. The security card must be kept safe, but should not be kept with the vehicle.