

DIMENSIONS

Defender 90

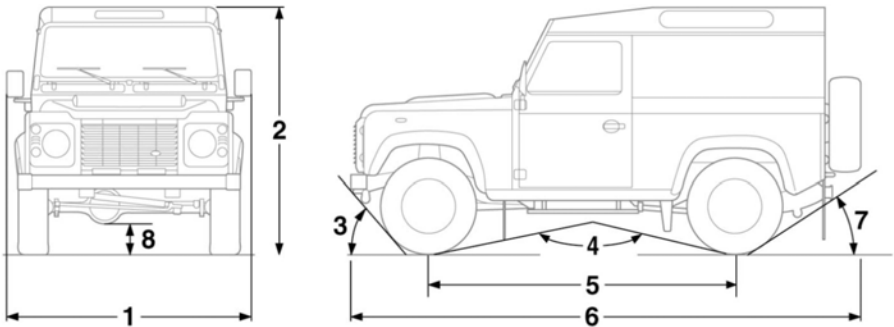

E135746

Item	Description	mm (inches)	Degrees
1	Width including mirrors	1992 (78)	-
1	Width with mirrors folded	1790 (70)	-
2	Maximum height - Soft Top / Pick up	2000 (79)	-
2	Maximum height - Station wagon / Hard Top	2182 (86)	-
3	Approach angle	-	47°
4	Breakover / Ramp angle	-	147°
5	Wheelbase	2360 (93)	-
6	Overall length - Soft Top / Pick up	3722 (147)	-
6	Overall length - Station Wagon / Hard Top	3880 (153)	-
7	Departure angle without tow hitch	-	47.1°
8	Ground clearance with 235 tyres	250 (9.8)	-
-	Maximum wading depth	500 (20)	-
-	Maximum gradient	-	45°
-	Maximum traverse angle	-	35°

Technical specifications

Defender 110

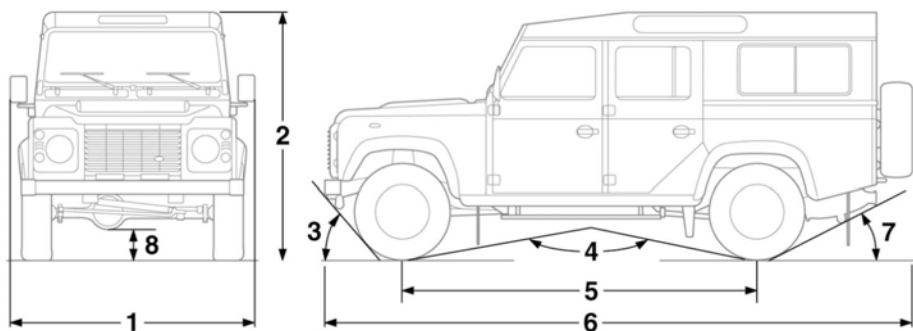

E135747

Item	Description	mm (inches)	Degrees
1	Width including mirrors	1992 (78)	-
1	Width with mirrors folded	1790 (70)	-
2	Maximum height - Soft Top / Pick up	2079 (82)	-
2	Maximum height - Station wagon / Hard Top / Double cab	2181 (86)	-
2	Maximum height - HCPU	2035 (80)	-
3	Approach angle	-	48.7°
4	Breakover / Ramp angle	-	149.7°
5	Wheelbase	2794 (110)	-
6	Overall length - Soft Top / Pick up / Double cab	4439 (175)	-
6	Overall length - Station Wagon / Hard Top	4626 (182)	-
6	Overall length - HCPU	4631 (182.3)	-
7	Departure angle without tow hitch	-	35.6°
8	Ground clearance with 235 tyres	250 (9.8)	-
-	Maximum wading depth	500 (20)	-
-	Maximum gradient	-	45°
-	Maximum traverse angle	-	35°

Defender 130

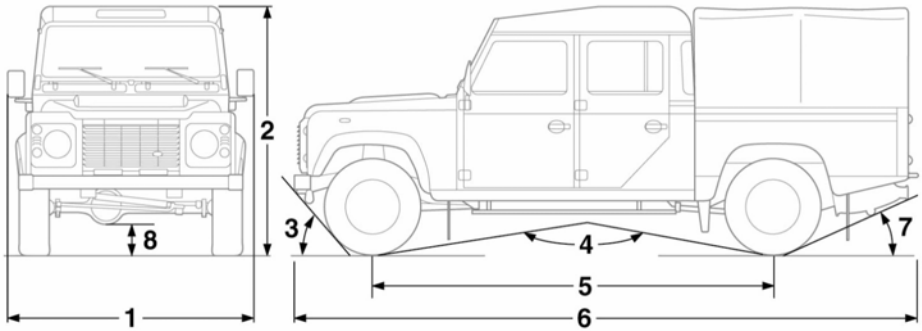

E135748

Item	Description	mm (inches)	Degrees
1	Width including mirrors	1992 (78)	-
1	Width with mirrors folded	1790 (70)	-
2	Maximum height	2181 (86)	-
3	Approach angle	-	49°
4	Breakover / Ramp angle	-	152.5°
5	Wheelbase	3226 (127)	-
6	Overall length - double cab HCPU	5157 (203)	-
7	Departure angle without tow hitch	-	35.2°
8	Ground clearance with 7.50 tyres	250 (9.8)	-
-	Maximum wading depth	500 (20)	-
-	Maximum gradient	-	45°
-	Maximum traverse angle	-	35°