

DIMENSIONS

Defender 90

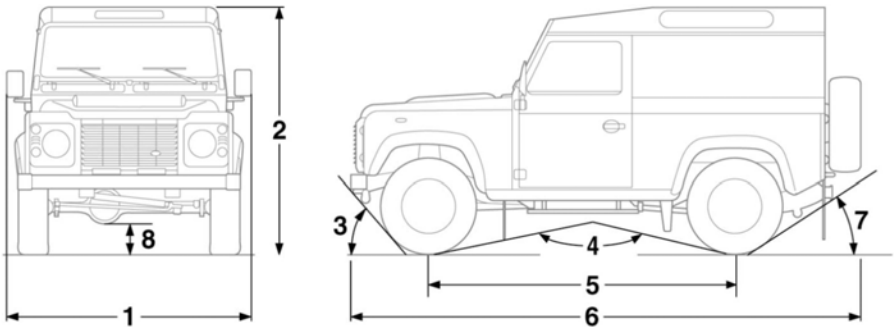

E135746

| Item | Description | mm (inches) | Degrees |
|------|---|-------------|---------|
| 1 | Width including mirrors | 1992 (78) | - |
| 1 | Width with mirrors folded | 1790 (70) | - |
| 2 | Maximum height - Soft Top / Pick up | 2000 (79) | - |
| 2 | Maximum height - Station wagon / Hard Top | 2182 (86) | - |
| 3 | Approach angle | - | 47° |
| 4 | Breakover / Ramp angle | - | 147° |
| 5 | Wheelbase | 2360 (93) | - |
| 6 | Overall length - Soft Top / Pick up | 3722 (147) | - |
| 6 | Overall length - Station Wagon / Hard Top | 3880 (153) | - |
| 7 | Departure angle without tow hitch | - | 47.1° |
| 8 | Ground clearance with 235 tyres | 250 (9.8) | - |
| - | Maximum wading depth | 500 (20) | - |
| - | Maximum gradient | - | 45° |
| - | Maximum traverse angle | - | 35° |

Technical specifications

Defender 110

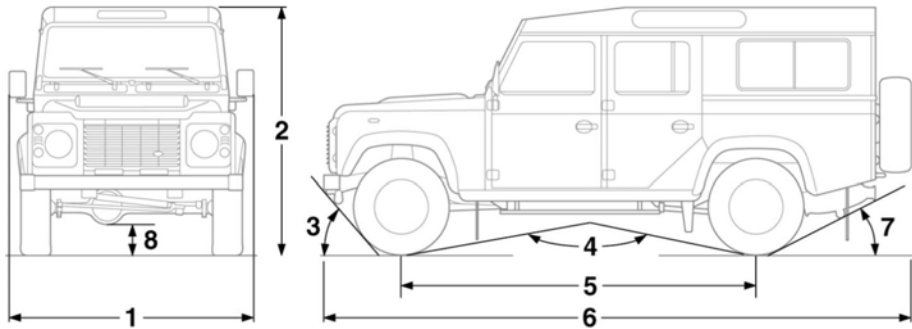

E135747

| Item | Description | mm (inches) | Degrees |
|------|--|--------------|---------|
| 1 | Width including mirrors | 1992 (78) | - |
| 1 | Width with mirrors folded | 1790 (70) | - |
| 2 | Maximum height - Soft Top / Pick up | 2079 (82) | - |
| 2 | Maximum height - Station wagon / Hard Top / Double cab | 2181 (86) | - |
| 2 | Maximum height - HCPU | 2035 (80) | - |
| 3 | Approach angle | - | 48.7° |
| 4 | Breakover / Ramp angle | - | 149.7° |
| 5 | Wheelbase | 2794 (110) | - |
| 6 | Overall length - Soft Top / Pick up / Double cab | 4439 (175) | - |
| 6 | Overall length - Station Wagon / Hard Top | 4626 (182) | - |
| 6 | Overall length - HCPU | 4631 (182.3) | - |
| 7 | Departure angle without tow hitch | - | 35.6° |
| 8 | Ground clearance with 235 tyres | 250 (9.8) | - |
| - | Maximum wading depth | 500 (20) | - |
| - | Maximum gradient | - | 45° |
| - | Maximum traverse angle | - | 35° |

Defender 130

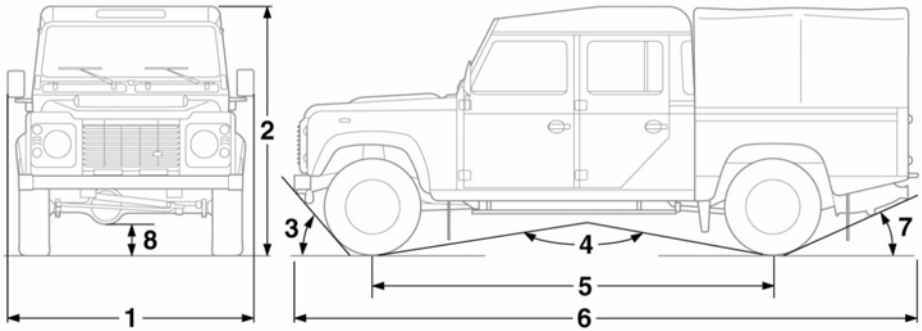

E135748

| Item | Description | mm (inches) | Degrees |
|------|-----------------------------------|-------------|---------|
| 1 | Width including mirrors | 1992 (78) | - |
| 1 | Width with mirrors folded | 1790 (70) | - |
| 2 | Maximum height | 2181 (86) | - |
| 3 | Approach angle | - | 49° |
| 4 | Breakover / Ramp angle | - | 152.5° |
| 5 | Wheelbase | 3226 (127) | - |
| 6 | Overall length - double cab HCPU | 5157 (203) | - |
| 7 | Departure angle without tow hitch | - | 35.2° |
| 8 | Ground clearance with 7.50 tyres | 250 (9.8) | - |
| - | Maximum wading depth | 500 (20) | - |
| - | Maximum gradient | - | 45° |
| - | Maximum traverse angle | - | 35° |