

Entering the vehicle

UNLOCKING THE VEHICLE

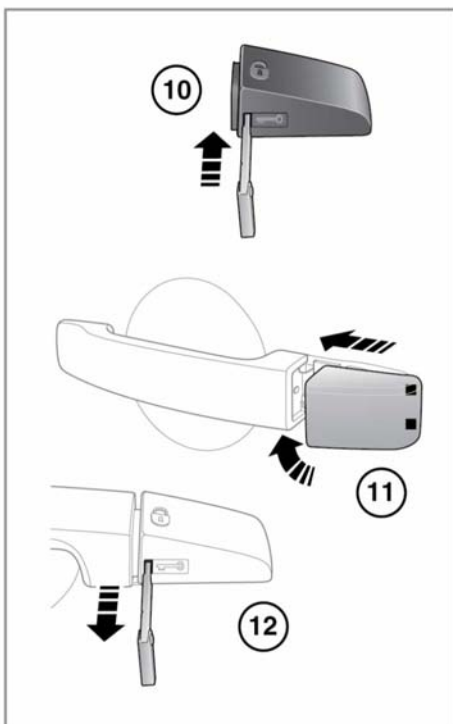

E145482

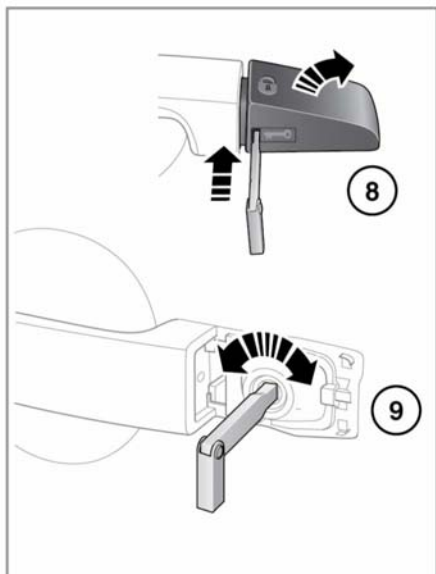
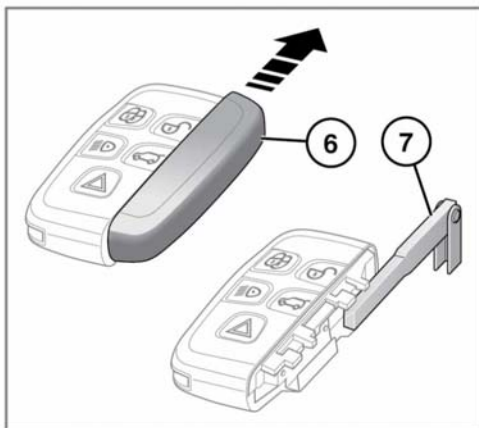
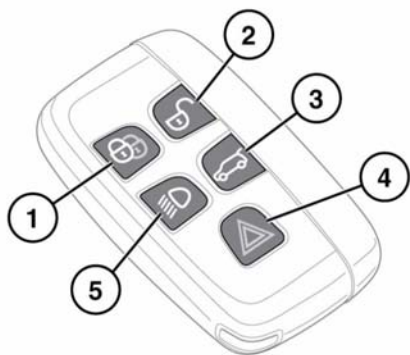

Any implanted medical device should be kept at a distance, of at least 22 cm (9 inches) away, from any of the vehicle transmitters/receivers during their normal operation. This is to avoid any possibility of interference between the vehicle's system and the medical device. For locations of vehicle mounted transmitters/receivers, see 207, SMART KEY TRANSMITTER LOCATIONS.



To prevent accidental operation, never leave the Smart key in the vehicle if children or animals are also left in the vehicle.

***Note:** The operational range of the Smart key will vary considerably depending on atmospheric conditions and interference from other transmitting devices.*

***Note:** If any door or the taildoor is unlocked 10 times within a short period, the latch is disabled for approximately one minute.*

1. Lock:

- Press to secure the vehicle. The vehicle can be Single or Double locked. See **8, SINGLE LOCKING**. See **8, DOUBLE LOCKING**.
See also **8, GLOBAL CLOSING**.

2. Unlock:

- Press briefly to unlock the vehicle and deactivate the alarm. The hazard warning lamps will flash twice to indicate that the vehicle is unlocked and the alarm has been deactivated. The interior lamps and puddle lamps will illuminate to assist entry to the vehicle. Power-fold mirrors will unfold (if enabled).
Press and hold to open all of the windows.

- The vehicle will unlock in 1 of 2 ways. Single point entry will unlock the driver's door and fuel filler flap only. A second press is required to unlock the remaining doors and taildoor.

Multi point entry unlocks all doors, the fuel filler flap, and the taildoor on the first press.

3. Taildoor release:

- Press briefly to release the taildoor. If the vehicle is locked and armed, the security system will remain active while the taildoor is open, but intrusion and inclination sensing systems will be disabled.

When closing the taildoor again, if the vehicle is already locked and armed, the hazard warning lamps will flash after a few seconds to confirm the full alarm system has been reactivated. There will also be an audible sound if the vehicle was Double locked.



Make sure the Smart key does not remain in the vehicle prior to closure. If the vehicle is in an area of localised Radio Frequency (RF) interference or the Smart key is shielded by metal objects, the vehicle may close and lock with no means of opening again.

4. Panic alarm:

- Press and hold for 3 seconds (or press 3 times within 3 seconds) to activate the horn and the hazard lamps.
- Once active for more than 5 seconds, the alarm can be cancelled by pressing the button and holding for 3 seconds (or pressing 3 times within 3 seconds).
- The panic alarm will also be cancelled if a valid Smart key is present when the START/STOP button is pressed.

5. Approach illumination: