

CHILD SAFETY LOCKS

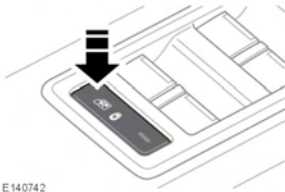

E140742



If children are to be carried in the rear seat positions, it is recommended that the rear door interior handles are disabled.

Press the switch to activate the child door locks and inhibit the rear windows. The LED indicator will illuminate when active and a message will display in the Message centre.

To switch off, press the switch again. The LED will extinguish and a message will display in the Message centre.

CHILD SEATS



For optimum safety, children should travel in the rear of the vehicle at all times; front passenger seat travel is not recommended. However, if it is essential that a child travels in the front (not permitted in Australia), set the vehicle seat fully rearward and seat the child in an approved forward-facing child seat. Do not use a rear-facing child seat - an inflating airbag could impact with the seat and cause serious injury.



Do not use a forward facing child seat until the child using it is above the minimum weight of 9 kg (20 lb.) and able to sit up unaided. Up to the age of 2, a child's spine and neck are not sufficiently developed to avoid injury in a frontal impact.



Do not allow a baby or infant to be held or carried on the lap. The force of a crash can increase effective body weight by as much as thirty times, making it impossible to hold onto the child.



Children typically require the use of a booster seat appropriate to their age and size, thereby enabling the seat belts to be properly fitted, reducing the risk of injury in a crash. Children could be endangered in a crash if their child restraints are not properly secured in the vehicle.



Do not use a child seat that hooks over the seat back. This type of seat cannot be satisfactorily secured and is unlikely to be safe for your child.



NEVER use a rearward facing child restraint on a seat protected by an ACTIVE AIRBAG in front of it, DEATH or SERIOUS INJURY to the CHILD can occur.

The seat belts fitted to your vehicle are designed for adults and larger children. For their safety it is very important for all infants and children under 12 years of age to be restrained in a suitable child safety seat appropriate to their age and size.

The following symbols warn against the use of a rear-facing child seat in the front passenger seat, when a front passenger airbag is fitted and is operational.



E132097

Child safety

This symbol is fixed to the end of the fascia on the passenger side.



E145193

This symbol is fixed to the passenger side sun-visor.

If it is essential that a child travels in the front passenger seat (and national legislation permits this), Land Rover recommends that the following preparations are made before fitting the child restraint.

- Disable the front passenger airbag.
- Adjust the front passenger seat fully rearwards.
- Adjust the lumbar support to its minimum support position.
- Adjust the seat cushion to its highest position. If cushion rake adjustment is possible, adjust it to its lowest position.
- Adjust the seat back to the fully upright position.
- Adjust the seat belt adjustable upper anchorage to its lowest position.

CHILD RESTRAINT CHECK LIST

Every time a child travels in the vehicle observe the following:-

- Carefully follow the instructions provided by the manufacturer of the restraint system.
- Always use the appropriate child restraints and adjust harnesses for every child, every trip.

- Adjust the harnesses for every child on every trip.
- Ensure that all slack is removed from the adult seat belt.
- Always attach the top tether when installing an ISOFIX seat.
- Always check the security of the child restraint.
- Do not dress a child in bulky clothing, or place any objects/padding between the child and the restraint.
- Regularly check the fit and condition of child restraints. If the fit is poor, or wear/damage is visible replace the restraint immediately.
- Set a good example - always wear your seat belt.



Child restraint anchorages are designed to withstand only those loads imposed by correctly fitted child restraints. Under no circumstances are they to be used for adult seat belts, harnesses or for attaching other items or equipment to the vehicle.

CHILD SEAT POSITIONING



Information given within the table is correct at the time of going to press. However, availability of child restraints may change. Please consult your Dealer/Authorised Repairer for the latest recommendation.

Note: The information contained in the following table may not be applicable to all countries. If you are in any doubt regarding the type and fitment of child seats seek advice from your Dealer/Authorised Repairer.



Crash statistics show that children are safest when properly restrained in a child or infant restraint system that is secured in a rear seating position.

Note: Ages given are approximate. In case of doubt, the child's weight, not age, should be used when considering an appropriate child seat.

Note: The legislation which governs how and where children should be carried when travelling in a vehicle, is subject to change. It is the responsibility of the driver to comply with all regulations in force.

Seating position	Mass group				
	0 = Up to 10 kg (22 lb) 0-9 months	0+ = Up to 13 kg (29 lb) 0-18 months	I = 9-18 kg (20-40 lb) 9 months to 4 years	II = 15-25 kg (33-55 lb) 4-9 years	III = 25-36 kg (55-80 lb) 8-12 years
Front passenger*	U	U	U	U	U
Rear seats	U	U	U	U	U

- U = Suitable for universal category restraints approved for this mass group.

* Always ensure that the passenger airbag has been disabled before using a child restraint in this seating position. The seat back needs to be adjusted to the fully upright position. If the head restraint has been removed, ensure it is refitted before the seat is used by a passenger.

Child size/age	Recommended seat
Group I	Britax/Römer Duo Plus
Group II and III	Britax/Römer Kid Plus

RECOMMENDED CHILD SEATS

Child size/age	Recommended seat
Groups 0 and 0+	Britax/Römer Baby Safe Plus

ISOFIX ANCHOR POINTS (not Australia)

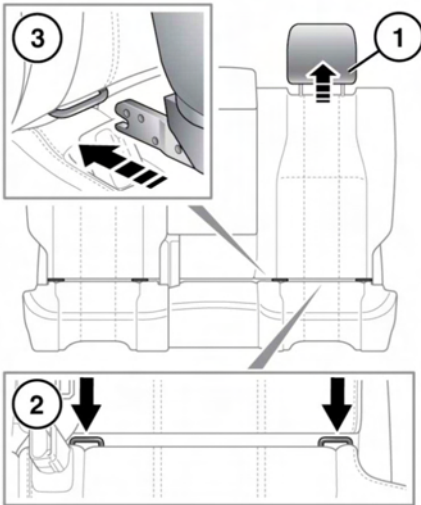

Both of the outer seat positions on the rear seat are equipped to accept ISOFIX restraints.



This symbol is shown on a label sewn into the seats to indicate the position of the ISOFIX lower anchorages.

To install an ISOFIX child seat:-

1. Raise or remove the head restraint.
2. ISOFIX anchor points are in the fold of the seats.
3. Slide the child seat locking mechanism into the anchor point.
4. Upper tether anchorages are provided on the rear of the 2 outer rear seats.
5. Hook the tether to the tether anchorage and tighten to secure.

Note: Always ensure that if an upper tether is provided, it is fitted and tightened correctly.

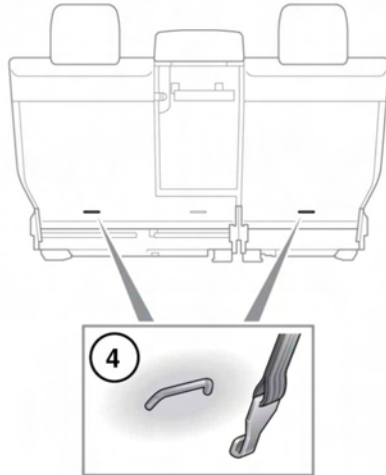

Test the security of the child restraint. To do this, attempt to pull the restraint away from the vehicle seat and twist the restraint from side to side. Even if the restraint appears secure, you should still check the anchor points visually, to ensure correct attachment.



Do not attempt to fit ISOFIX restraints to the centre rear seating position. The anchor bars are not designed to hold an ISOFIX restraint in this position.



If the restraint is not correctly anchored, there is a significant risk of injury to the child in the event of a collision or emergency braking.

Note: Always refit a removed head restraint after the child restraint is removed. See 25, **HEAD RESTRAINT REMOVAL.**

ISOFIX child seat positions

Mass group as shown on child restraint	Size classes	Fixtures	Rear outboard seats
Carrycot	F/G	ISO L1/L2	X
0 = Up to 10 kg (22 lb) 0-9 months	E	ISO R1	IL*
0+ = Up to 13 kg (29 lb) 0-18 months	C/D/E	ISO R1/R2/R3	IL*
I = 9 to 18 kg (20 to 40 lb) 9 months - 4 years	C/D	ISO R2/R3	X
	A/B1/B	ISO F2/F2X/F3	IUF
II = 15 to 25 kg (33 to 55 lb) 4-9 years	N/A	N/A	N/A
III = 22 to 36 kg (49 to 80 lb) 8-12 years	N/A	N/A	N/A

- IUF = Suitable for ISOFIX forward child restraint systems of universal category approved for use in the mass group.
- IL = These ISOFIX child restraint systems are of the specific vehicle, restricted or semi-universal categories.
- X = Not suitable for ISOFIX child restraint fitment in this mass group.
- * = Child seat suitable for use in these locations, is the Britax/Römer Baby Safe Plus ISOFIX.

Note: Ages given are approximate. In case of doubt, the child's weight not age should be used when considering an appropriate child seat.

Note: The information contained in the table may not be applicable to all countries. If you are in any doubt regarding the type and fitment of child seats seek advice from your Dealer/ Authorised Repairer.

Note: ISOFIX anchorages are provided for rear outer seating positions. ISOFIX child restraints should be securely attached following the manufacturers instructions at these locations only.

INSTALLING TETHER ANCHORAGE CHILD RESTRAINTS



Child restraint anchorages are designed to withstand only those loads imposed by correctly fitted child restraints. Under no circumstances are they to be used for adult seat belts, harnesses or for attaching other items or equipment to the vehicle.



Always follow the child seat or restraint system manufacturer's instructions when fitting tether straps.



When fitting a child seat or restraint system, always pass the tether strap over the top of the seat back and beneath the head restraint.



If a child seat or restraint system is to be fitted to the centre seating position, the centre armrest must be in the stowed position (folded into the seat).

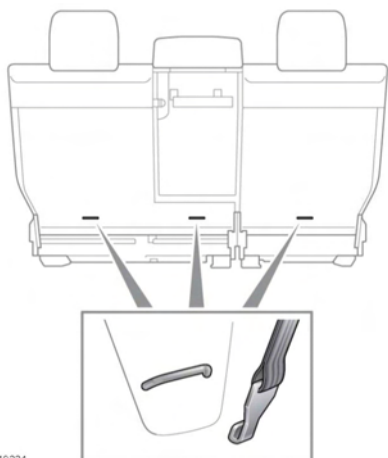

E149221

Your vehicle is equipped with anchorage points on the back of the second row seat frames. These should be used to attach straps from child seats or restraint systems.

- Install the child restraint securely in 1 of the rear seating positions.
- Pass the tether strap over the seat back and beneath the head restraint for the outer seat positions.

Note: For the centre seat position, pass the tether strap over the fixed head restraint.

- Attach the tether strap hook to the tether anchor point on the back of the seat. Ensure that the tether strap hook is facing the correct way (see illustration).
- Tighten the tether strap according to the child restraint manufacturer's instructions.

Note: A tether anchorage is provided for the centre seat position. Do not use this anchor position with an ISOFIX child seat.

BOOSTER SEATS

In a situation where a child is too large to fit into a child safety seat but is still too small to safely use just the 3 point belt, a booster seat is recommended for maximum safety. Follow the manufacturer's instructions for fitting and use, then adjust the seat belt to suit. See **33, CHILD SEAT POSITIONING**.