

# Tire pressure monitoring system (TPMS)

## TIRE PRESSURE MONITORING SYSTEM

### **⚠ WARNING**

TPMS provides a low pressure warning and does not re-inflate your tires. Tire pressures should be checked regularly using an accurate pressure gauge when the tires are cold.

### **⚠ WARNING**

TPMS can NOT register damage to a tire. Regularly check the condition of your tires, especially if the vehicle is driven off-road.

### **NOTICE**

*When inflating tires, care should be taken to avoid bending or damaging the TPMS valve. Always ensure correct alignment of the inflation head to the valve stem.*

**Note:** Non-approved accessories may interfere with the system. If this occurs, **TIRE PRESSURE MONITORING FAULT** is displayed in the Message center.

**Note:** Different types of tire may affect TPMS performance. Always replace tires in accordance with recommendations.

Your vehicle is equipped with a TPMS which monitors pressure in each tire, including the full-size spare tire. Compact spare tires are not fitted with sensors and are consequently not monitored. See **217, TEMPORARY USE SPARE WHEEL AND TIRE CHANGE**.

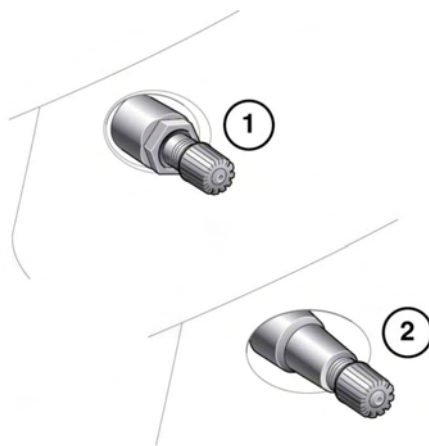

E132513

Wheels fitted with TPMS can be visually identified by the external metal lock nut and valve (1). All Land Rover non-TPMS wheels have a rubber valve fitted (2).

**Note:** At each tire change, a special service kit is required for the TPMS valve.

Each tire, including the spare (if provided), should be checked monthly when cold and inflated to the inflation pressure on the vehicle placard or tire inflation pressure label. (If your vehicle has tires of a different size than the size indicated on the vehicle placard or tire inflation pressure label, you should determine the proper tire inflation pressure for those tires.) See **220, TIRE PRESSURE LABEL**.

As an added safety feature, your vehicle has been equipped with a tire pressure monitoring system (TPMS) that illuminates a low tire pressure telltale when one or more of your tires is significantly under-inflated, accompanied with a message in the Message center.

## Tire pressure monitoring system (TPMS)

Accordingly, when the low tire pressure telltale illuminates, you should stop and check your tires as soon as possible, and inflate them to the proper pressure. Driving on a significantly under-inflated tire causes the tire to overheat and can lead to tire failure. Under-inflation also reduces fuel efficiency and tire tread life, and may affect the vehicle's handling and stopping ability.

Please note that the TPMS is not a substitute for proper tire maintenance, and it is the driver's responsibility to maintain correct tire pressure, even if under-inflation has not reached the level to trigger illumination of the TPMS low tire pressure telltale.

Your vehicle has also been equipped with a TPMS malfunction indicator to indicate when the system is not operating properly.

The TPMS malfunction indicator is combined with the low tire pressure telltale. When the system detects a malfunction, the telltale will flash for approximately one minute and then remain continuously illuminated. This sequence will continue upon subsequent vehicle start-ups as long as the malfunction exists.

When the malfunction indicator is illuminated, the system may not be able to detect or signal low tire pressure as intended. TPMS malfunctions may occur for a variety of reasons, including the installation of replacement or alternate tires or wheels on the vehicle that prevent the TPMS from functioning properly. Always check the TPMS malfunction telltale after replacing one or more tires or wheels on your vehicle to ensure that the replacement or alternate tires and wheels allow the TPMS to continue to function properly.

### VEHICLE LOADING

When the vehicle is delivered, tire pressures will be set to those displayed on the tire placard. See **220, TIRE PRESSURE LABEL**. These pressures are suitable for loading the vehicle up to GVW (Gross Vehicle Weight). The TPMS will be set to monitor these tire pressures.

It is possible to select a TPMS light load level that corresponds to a set of reduced tire pressures. This light load setting is referred to as the Comfort setting and ride comfort will be improved providing the weight restriction for passengers and luggage is not exceeded. See **221, TIRE PRESSURES**.

TPMS levels can be set via the **Vehicle Set-Up** menu in the Message center. See **73, INSTRUMENT PANEL MENU**.

**Note:** *The TPMS setting must correspond with the current tire pressures.*

**Note:** *Make sure that the tire pressures are correct for the vehicle load.*

When the ignition is switched on, a TPMS message will be displayed in the Message center to indicate which pressure setting is being monitored. The message will be either **TPMS Set For Heavy Load** or **TPMS Set For Light Load**.

### **NOTICE**

*If the monitored TPMS setting does not match the current tire pressures, action must be taken immediately to ensure that they do match. Adjust tire pressures to match or change the TPMS monitoring setting.*

# Tire pressure monitoring system (TPMS)

## FULL SIZE SPARE WHEEL AND TIRE CHANGE

The system will automatically recognize any changes in wheel positions. The vehicle must be stationary for 15 minutes during the wheel and tire change, to ensure that the system can detect the change. After driving above 18 mph (25 km/h) any deflation warning should clear within approximately 5 minutes.

## TEMPORARY USE SPARE WHEEL AND TIRE CHANGE

If the temporary use spare wheel is fitted, the system will automatically recognize the change in wheel positions. After approximately 10 minutes of driving above 18 mph (25 km/h), the message **FRONT[REAR] RIGHT[LEFT] TIRE PRESSURE NOT MONITORED** will be displayed, accompanied by illumination of the warning lamp.

The warning lamp will first flash and then illuminate continuously. Extended use of the temporary use spare wheel will trigger the message **TIRE PRESSURE MONITORING SYSTEM FAULT**.

This TPMS display sequence will be activated at every ignition cycle until the temporary spare wheel is replaced by a full-size road wheel with a TPMS sensor fitted.

***Note:** If in use, always replace the temporary spare wheel before having a TPMS fault investigated.*

## TYPE APPROVAL NUMBERS

TPMS

### United States of America

This device complies with part 15 of the FCC rules. Operation is subject to the following two conditions:

(1) this device may not cause harmful interference, and

(2) this device must accept any interference received, including interference that may cause undesired operation.

### Canada

This device complies with Industry Canada Standard IC - RSS-210. Operation is subject to the following two conditions:

(1) this device may not cause interference, and

(2) this device must accept any interference, including interference that may cause undesired operation of the device.

***Note:** Changes or modifications not expressly approved by the manufacturer could void the user's authority to use the equipment.*

The TPMS radio frequency approval numbers for the USA and Canada are:

<b>USA FCC ID:</b>	KR5S120123
	KR5S180021
	5WK49097
<b>Canada IC:</b>	267T-S120123
	267T-S180021
	267T-5WK49097