

# Wheel changing

11. With all wheels on the ground and the jack removed, fully tighten the wheel nuts. The wheel nuts must be tightened in sequence (see illustration) to the correct torque of 133 Nm (98 lb.ft).

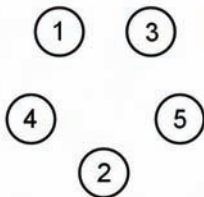





E132675

**Note:** If it is not possible to torque the wheel nuts when a wheel is replaced, they should be set to the correct torque as soon as possible.

If an alloy spare wheel is to be fitted, using a suitable blunt tool, knock the centre cap out of the removed wheel. Using hand pressure only, press the centre cap into the newly fitted spare. Check and adjust the tyre pressure as soon as possible.

## IMPORTANT – USE OF SPARE TYRE

-  Adhere to the instructions on the temporary spare warning label, affixed to the wheel.
-  Where fitted the temporary use spare wheel is **FOR TEMPORARY USE ONLY**. Drive with caution while the temporary spare wheel is fitted. Ensure that an original size wheel and tyre are fitted as soon as possible.
-  Do not fit more than one temporary spare wheel.
-  Do not exceed 80 km/h (50 mph) while the temporary spare wheel is fitted.
-  The tyre pressure in the temporary spare wheel should be 420 kPa (4.2 Bar/60 psi).



DSC must be switched on while the temporary spare wheel is in use.



Traction devices such as snow chains cannot be used with a temporary spare wheel.

## STOWING THE CHANGED WHEEL

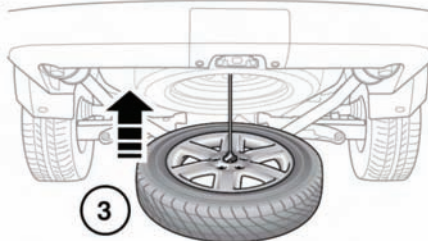
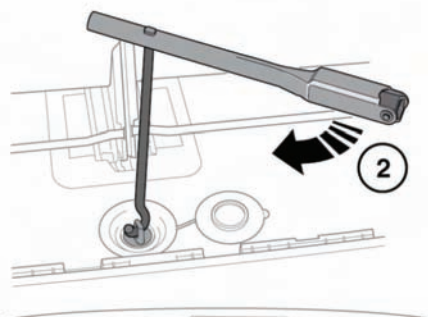
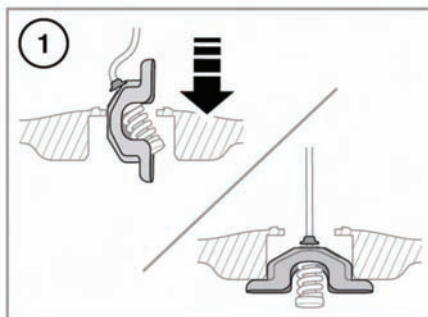

E147458



Do not stow the wheel while the vehicle is raised on the jack.



Do not use power tools to raise the spare wheel. Doing so may damage the mechanism.

- Place the wheel under the vehicle with the styled face uppermost.
- Place the lifting lug through the centre of the wheel **(1)** and locate it in position.
- Winch up the wheel using the jack handle and wheel brace to turn the wheel hoist winch spindle anti-clockwise. **(2)**.
- Continue to wind up until the wheel hoist reaches its upper position **(3)**. This is indicated by an audible noise from the winch and a distinct movement, which will be felt through the jack handle and wheel brace.
- Check that the wheel has returned to the same position as the spare wheel was in before it was removed. If in doubt, lower the winch slightly, adjust the wheel position and repeat the previous step above.

The wheel **must** be securely retained in its correct position by the winch mechanism, or it could become loose.

- Replace the cover over the wheel winch spindle. As the underside of the cover is exposed to the same conditions as the underside of the vehicle, ensure that it is firmly in place.

Replace all the tools into the vehicle tool kit, see **217, TOOL KIT**. Make sure they are stowed securely.

**Note:** *If for any reason, the spare wheel, or the replaced wheel is not to be fitted back in the vehicle's hoist, the wheel hoist should be rewound as follows.*

*Position the lifting lug level on the cable, and wind up the hoist mechanism until it reaches its uppermost position. This is indicated by an audible noise from the winch and a distinct movement, which will be felt through the jack handle and wheel brace.*