





## HEAD RESTRAINTS

-  Adjust, so that the top of the head restraint is the same height as the top of the seat occupant's head. Incorrect adjustment increases the risk of death or serious injury in the event of a collision.
-  It is possible to swivel the head restraint forwards or backwards. For greater protection in the event of a collision, the head restraint should be adjusted so that it is as close to the back of the head as possible.
-  Do not drive, or carry passengers with the head restraints removed from occupied seats. The absence of a correctly adjusted head restraint increases the risk of neck injury in the event of a collision.
-  Never adjust the head restraints while the vehicle is in motion.
-  Always store a removed head restraint securely.

## ELECTRIC HEAD RESTRAINTS

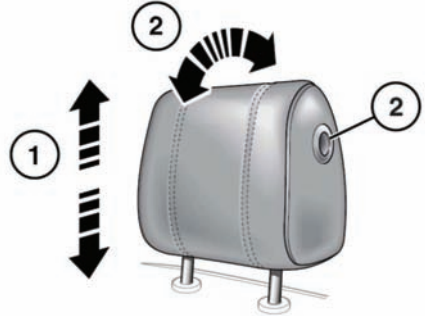

E139074

1. To adjust the height of the head restraint.
  - Front (see **16, ELECTRIC SEATS**).
  - Rear (see **19, BUSINESS CLASS SEATS**).
2. To adjust the angle of the head restraint, press the locking button on the side of the restraint and tilt to the desired position.

**Note:** There is no angle adjustment on headrests where a rear media screen is fitted.

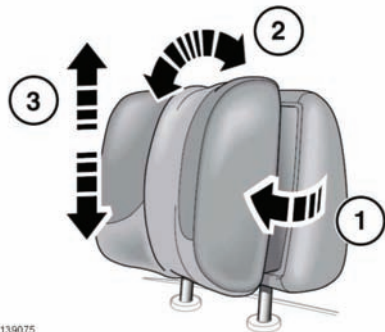

E139075

1. Pull the wing heads forward to the first or second position.
2. Tilt the head restraint to adjust the angle.