

## TOPPING UP THE OIL

- ❗ Your vehicle warranty may be invalidated if damage is caused by using oil that does not meet the required specification.
- ❗ Failure to use an oil that meets the required specification could cause excessive engine wear, a build up of sludge and deposits, and increase pollution. It could also lead to engine failure.
- ❗ Overfilling with oil could result in severe engine damage. Oil should be added in small quantities and the level re-checked to ensure that the engine is not overfilled.

1. Remove the oil filler cap.
2. Add oil as instructed by the display.
3. Clean up any oil spilled during topping-up.
4. Check the oil level again after 10 minutes.

It is essential to use the correct specification oil, and to ensure it is suitable for the climatic conditions in which the vehicle is to be operated. See **210, LUBRICANTS AND FLUIDS**.

**Note:** The approximate quantity of oil required to raise the level from **MIN** to **MAX** is 1.5 litres (2.6 pints).

## CHECKING THE COOLANT LEVEL

- ❗ Running the engine without coolant will cause serious engine damage.

The coolant level in the expansion tank should be checked at least weekly (more frequently in high mileage or arduous operating conditions). Always check the level when the system is cold.

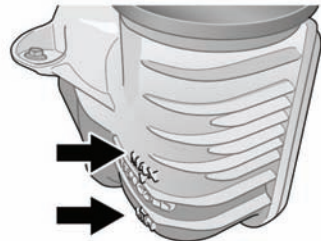
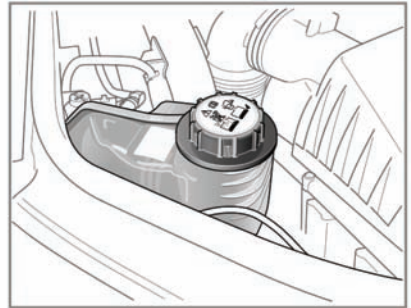
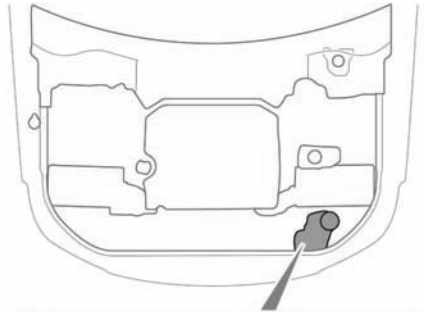

E139214

Ensure the coolant level remains between the **MIN** and **MAX** indicator marks located on the side of the expansion tank. Ignore any coolant