

## ISOFIX ANCHOR POINTS (not Australia)

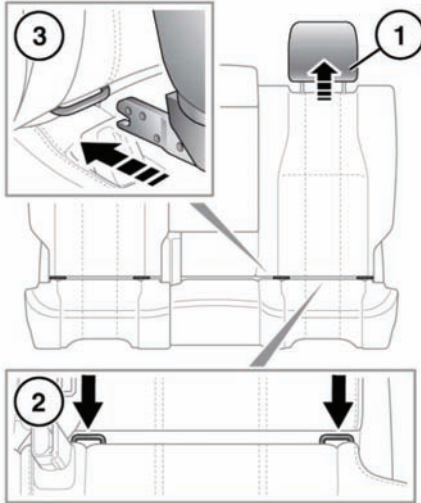

E143653

Both of the outer seat positions on the rear seat are equipped to accept ISOFIX restraints.



This symbol is shown on a label sewn into the seats to indicate the position of the ISOFIX lower anchorages.

To install an ISOFIX child seat:-

1. Raise or remove the head restraint.
2. Lift the velcro flap to expose the ISOFIX locking mechanism.
3. Slide the child seat into the locking mechanism.
4. Upper tether anchorages are provided behind the two outer rear seats.  
Lower the flap(s) covering the tether anchorages
5. Secure the tether to the tether anchorage.

**Note:** Always ensure that if an upper tether is provided, it is fitted and tightened correctly.

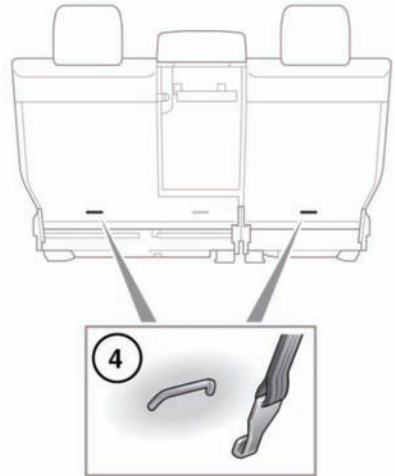

Test the security of the child restraint. To do this, attempt to pull the restraint away from the vehicle seat and twist the restraint from side to side. Even if the restraint appears secure, you should still check the anchor points visually, to ensure correct attachment.



**Do not attempt to fit ISOFIX restraints to the centre rear seating position. The anchor bars are not designed to hold an ISOFIX restraint in this position.**



**If the restraint is not correctly anchored, there is a significant risk of injury to the child in the event of a collision or emergency braking.**

**Note:** Always refit a removed head restraint after the child restraint is removed. See **24, HEAD RESTRAINT REMOVAL.**

## ISOFIX child seat positions

Mass group as shown on child restraint	Size classes	Fixtures	Rear outboard seats
Carrycot	F/G	ISO L1/L2	X
0 = Up to 10 kg (22 lb) 0-9 months	E	ISO R1	IL*
0+ = Up to 13 kg (29 lb) 0-18 months	C/D/E	ISO R1/R2/R3	IL*
I = 9 to 18 kg (20 to 40 lb) 9 months - 4 years	C/D A/B1/B	ISO R2/R3 ISO F2/F2X/F3	X IUF
II = 15 to 25 kg (33 to 55 lb) 4-9 years	N/A	N/A	N/A
III = 22 to 36 kg (49 to 80 lb) 8-12 years	N/A	N/A	N/A

- IUF = Suitable for ISOFIX forward child restraint systems of universal category approved for use in the mass group.
- IL = These ISOFIX child restraint systems are of the specific vehicle, restricted or semi-universal categories.
- X = Not suitable for ISOFIX child restraint fitment in this mass group.
- \* = Child seat suitable for use in these locations, is the Britax/Römer Baby Safe Plus ISOFIX.

**Note:** Ages given are approximate. In case of doubt, the child's weight not age should be used when considering an appropriate child seat.

**Note:** The information contained in the table may not be applicable to all countries. If you are in any doubt regarding the type and fitment of child seats seek advice from your Dealer/ Authorised Repairer.

**Note:** ISOFIX anchorages are provided for rear outer seating positions. ISOFIX child restraints should be securely attached following the manufacturer's instructions at these locations only.