

## TOWING EYES



The towing eyes at the front and rear of the vehicle are designed for on-road recovery only. If they are used for any other purpose, it may result in vehicle damage and serious injury.



Remove the front and rear towing eye covers before driving off-road, to prevent damage or loss.

The front and rear towing points are located behind removable covers.

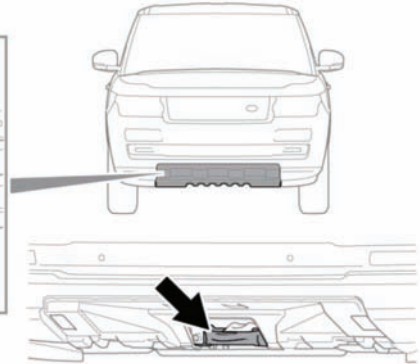
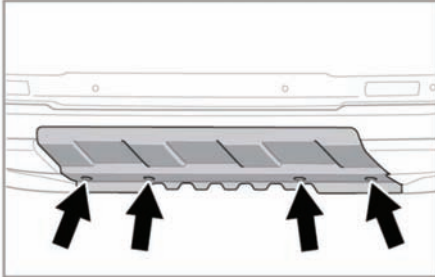

E142344

1. To release the front cover, rotate each of the fasteners 90 degrees counter clockwise with a coin (or similar).
2. To remove the cover, lower the top edge and then pull the cover forward. When refitting, first ensure the two lugs at the bottom edge of the cover engage with the holes in the body panel then secure in position by rotating each of the fasteners 90 degrees clockwise.

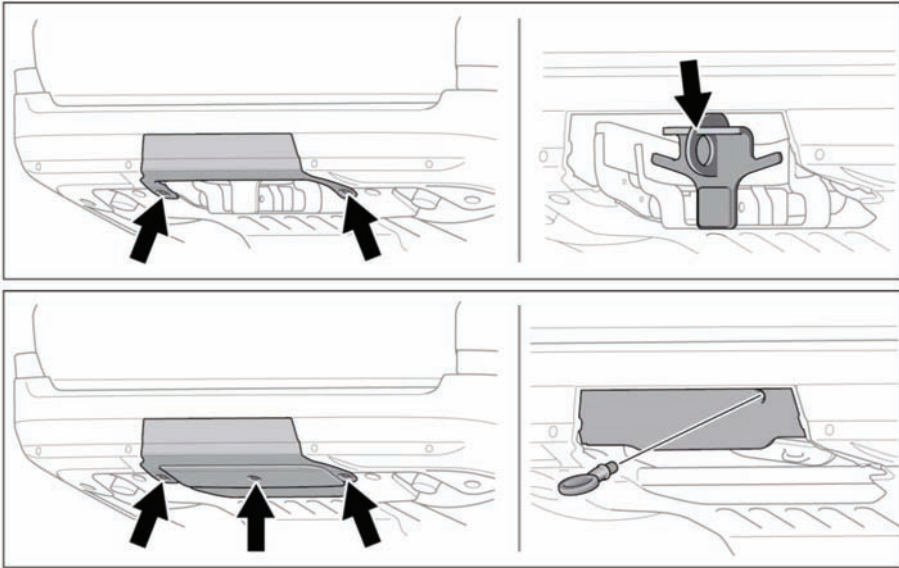
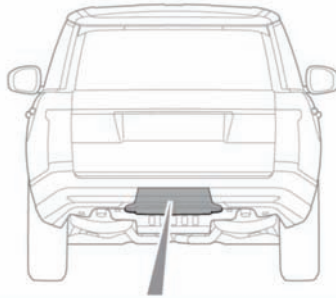

E143679

1. To release the rear cover, rotate each of the fasteners 90 degrees counter clockwise with a coin (or similar), to release the lower edge.
2. Rotate the cover to release the hooks at the top. Remove the cover.
3. Vehicles fitted with Powered tow bar, a towing eye is included in the tool kit, located in the under-floor area of the loadspace.
4. Screw the towing eye anticlockwise into its fixing, until secure.
5. When refitting the rear cover, ensure that the four hooks on the top edge of the cover engage in the body panel then secure in position by rotating each of the fasteners 90 degrees clockwise.

The rear towing point may be used to tow another vehicle if required.