

POWERED TOW BAR

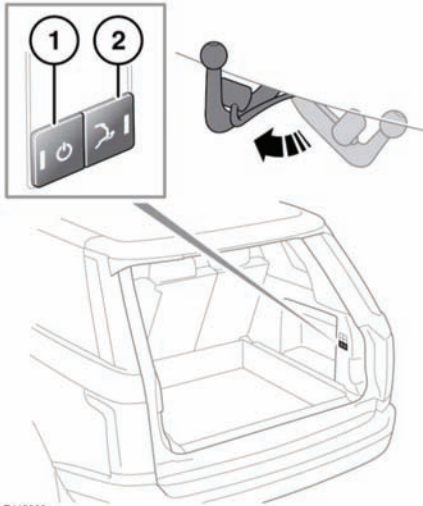

E142363

The electrically deployable tow bar is hidden in its stowed position behind the bumper. It can be deployed using the buttons located on the right side of the loadspace.

Before activating the tow bar the ignition must be switched off. Always check for obstructions to the tow bar.



Make sure the tow bar is fully deployed before connecting a trailer/caravan.

1. Press tow bar on/off button (1). The green LED will illuminate on deploy/stow button (2).
2. Press and release the deploy/stow button (2), the tow bar will move into position. Alternatively, press and hold the deploy/stow button (2), to increase the speed of tow bar deployment.

During movement a series of long warning beeps will sound, also the green LED will flash. Full deployment is confirmed with a short double beep and all LEDs will extinguish.

To stow the tow bar, repeat the above procedure using the tow bar on/off button (1) and deploy/stow button (2).

Note: To stop movement of tow bar press either button during deployment.

Note: During movement if an obstruction/stall occurs, the green LED will flash and a 10 second beep will sound. Pressing the deploy/stow button while the green LED is flashing will reverse the movement of the tow bar in order to avoid the obstruction.

Note: If there is debris on the mechanism (e.g. ice), pressing and holding the deploy/stow button will increase power output.

Note: If the tow bar does not move or is impacted but not damaged, it may need to be reset. In cases of damage refer to your Land Rover Dealer/Authorised Repairer.

Powered tow bar reset

If the tow bar movement stops unexpectedly and is partially deployed or stowed, it will need to be reset. This procedure must be completed within 2 minutes and begin from a stowed position.

1. Firmly depress the brake pedal.
2. Switch the engine on and off.
3. Release the brake pedal.
4. Switch the ignition on and off.
5. Press tow bar on/off button (1). The green LED will illuminate on the deploy/stow button (2).
6. Press and release the deploy/stow button (2), until the tow bar moves into the deployed position.
7. Press and release the deploy/stow button (2) again, until the tow bar moves into the stowed position.

During movement, a series of long warning beeps will sound, and the green LED will flash. The tow bar is now reset.