

Technical specifications

GTW = Maximum permissible weight of vehicle and braked trailer including their respective loads.

Variant	Weight	Market applicability
90	6005 kg - 13239 lb	UK and Europe
110 Standard Duty	6550 kg - 14440 lb	UK and Europe
110 Heavy Duty	7000 kg - 15432 lb	UK and Europe
130 DC Cab	6880 kg - 15167 lb	UK and Europe
90 Standard Duty	5900 kg - 13007 lb	Rest of World
90 Heavy Duty	6050 kg - 13338 lb	Rest of World
110 Standard Duty	6550 kg - 14440 lb	Rest of World
110 Heavy Duty	7000 kg - 15432 lb	Rest of World
130 DC Cab	7000 kg - 15432 lb	Rest of World

DIMENSIONS

Defender 90

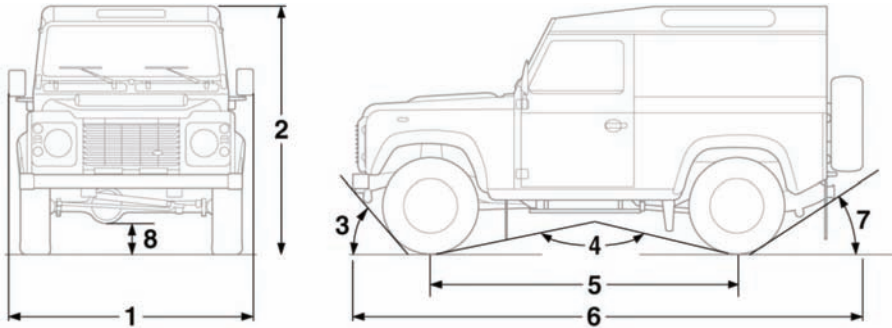

E135746

Item	Description	mm / inches	Degrees
1	Width including mirrors	1992 / 78	-
1	Width with mirrors folded	1790 / 70	-
2	Maximum height - Soft Top	2035 / 80	-
2	Maximum height - Station wagon	2021 / 79.5	-
3	Approach angle	-	47°
4	Breakover / Ramp angle	-	147°
5	Wheelbase	2360 / 93	-
6	Overall length - Soft Top	3649 / 144	-

Item	Description	mm / inches	Degrees
6	Overall length - Station Wagon	3940 / 155	-
7	Departure angle without tow hitch	-	47°
8	Ground clearance with 235 tyres	250 / 9.8	-
-	Maximum wading depth	500 / 20	-
-	Maximum gradient	-	45°
-	Maximum traverse angle	-	35°

Defender 110

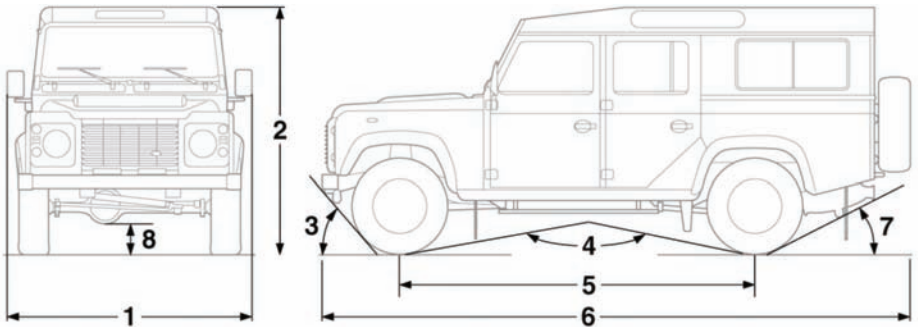

E135747

Item	Description	mm / inches	Degrees
1	Width including mirrors	1992 / 78	-
1	Width with mirrors folded	1790 / 70	-
2	Maximum height - Soft Top	2035 / 80	-
2	Maximum height - Station wagon	2021 / 79.5	-
3	Approach angle	-	49°
4	Breakover / Ramp angle	-	150°
5	Wheelbase	2794 / 110	-
6	Overall length - Soft Top	4370 / 172	-
6	Overall length - Station Wagon	4685 / 184.5	-
6	Overall length - HCPU	4631 / 182.3	-
6	Overall length - Double cab	4438 / 174.7	-
7	Departure angle without tow hitch	-	35°
8	Ground clearance with 235 tyres	250 / 9.8	-

Technical specifications

Item	Description	mm / inches	Degrees
-	Maximum wading depth	500 / 20	-
-	Maximum gradient	-	45°
-	Maximum traverse angle	-	35°

Defender 130

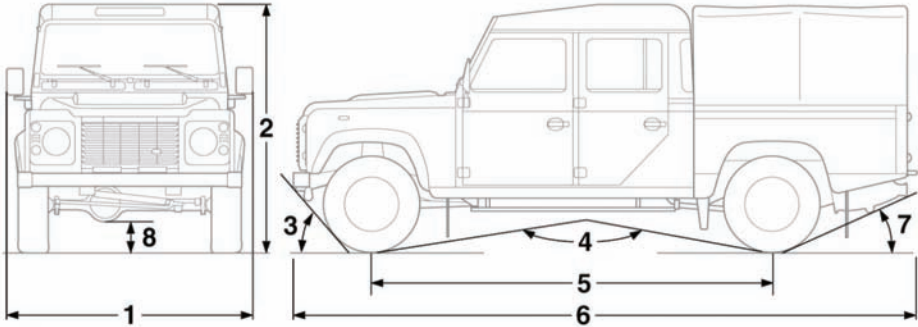

E135748

Item	Description	mm / inches	Degrees
1	Width including mirrors	1992 / 78	-
1	Width with mirrors folded	1790 / 70	-
2	Maximum height	2035 / 80	-
3	Approach angle	-	49°
4	Breakover / Ramp angle	-	153°
5	Wheelbase	3225 / 127	-
6	Overall length - double cab HCPU	5170 / 204	-
7	Departure angle without tow hitch	-	35°
8	Ground clearance with 7.50 tyres	250 / 9.8	-
-	Maximum wading depth	500 / 20	-
-	Maximum gradient	-	45°
-	Maximum traverse angle	-	35°