

THE EXTERIOR

- ❗ Remove any heavy deposits of mud and dirt with a hose before washing the vehicle.
- ❗ Never aim a hose water jet directly at the engine air intake, heater air intakes, body seals or at any components which may be damaged.
- ❗ Do not use a high pressure washer or steam cleaner in the engine compartment.
- ❗ Following cleaning of the vehicle exterior (particularly with a pressure washer), it is recommended that the vehicle is taken for a short drive to dry out the brakes.
- ❗ Substances which are corrosive, such as bird droppings and tree resin, can damage the vehicle's paintwork and should be removed as soon as possible.
- ❗ Use only cleaning products approved for use on vehicles.
- ❗ Camera lenses must be treated with care. Clean with a low pressure hose and wipe with a damp cloth.

Stubborn stains such as tar spots and grease on the paintwork may require the use of white spirit. After use, ensure the area is washed immediately with warm soapy water to remove all traces of the spirit.

Note: Do not apply polish to any unpainted areas of the bumper mouldings. It will become ingrained in the textured finish.

SENSORS

- ❗ When washing the vehicle do not aim high pressure water jets directly at any of the sensors. Do not use abrasive materials or hard/sharp objects to clean the sensors. Only use approved vehicle shampoo.

Park assist and Parking aids sensors should be kept clean to maintain accuracy and performance.

UNDER BODY MAINTENANCE

Regularly flush the underbody with plain water, and pay particular attention to areas where mud and debris collect.

If damage or corrosion are detected, have the vehicle checked by your Dealer/Authorised Repairer as soon as possible.

AFTER OFF-ROAD DRIVING

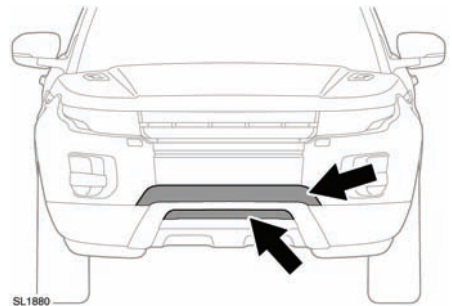

- ❗ Ensure that the areas around air intakes and the front grille are clean and clear of debris. Pay particular attention to the lower grille and radiator. Failure to do so may cause the engine to overheat, leading to severe engine damage.

Ensure that the vehicle underside is cleaned as soon as possible after driving off-road.