

When activated, the yellow misfuel protector will be visible inside the filler neck. It will prevent fuel flow into the tank. Before fuelling can continue with the correct fuel, the device will need to be reset.

The reset tool is located in the luggage compartment.

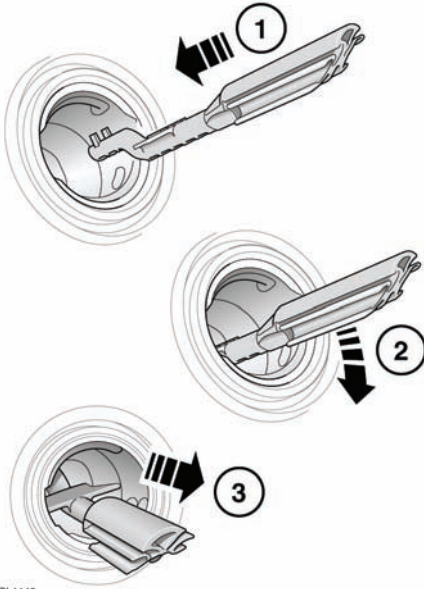

Reset the misfuel protection device as follows:

1. Insert the reset tool with the teeth uppermost, as far as it will go into the filler neck.
2. Locate the teeth by pushing down the top of the reset tool.
3. With the top of the tool pressed down and the teeth engaged, slowly pull the tool out of the filler neck to reset the device.

⚠ Do not twist the device, once the teeth have engaged.

Note: The yellow part of the protection device should no longer be visible in the filler neck.

Return the reset tool to the luggage compartment.

FUEL TANK CAPACITY

Avoid the risk of running out of fuel and never intentionally drive the vehicle when the fuel gauge indicates that the tank is empty. When refuelling your vehicle after the fuel gauge reads empty, you may not be able to add the fuel quantity, as there will be a small reserve remaining in the tank. See 217, **CAPACITIES**.

FUEL SPECIFICATION

Petrol	91-98 RON
Diesel	EN 590

⚠ Diesel vehicles in Algeria, Egypt, Libya, Morocco, India, Pakistan and Tunisia must only use premium diesel fuel.