

KEYLESS ENTRY

Keyless entry allows the vehicle to be opened if a Smart Key is within 1.0 m (3 ft) of the door handle or the tailgate external switch.

- ⚠ The Smart Key may not be detected if it is placed within a metal container or if it is shielded by a device with a back-lit LCD screen, such as a smart phone, laptop (including in a laptop bag), games console etc. Keep the Smart Key clear of such devices when attempting Keyless entry or Keyless starting.

Note: *The Smart Key needs only to be on the driver's person or in a non-metallic bag or briefcase. It does not need to be exposed or handled.*

To enter the vehicle, just pull the door handle. The alarm will be disarmed and the doors unlocked according to the current unlock/entry setting (Single or Multi-Point). The hazard warning lamps will flash twice as 'unlock' confirmation. Power folded mirrors will fold out (if enabled).

Note: *If Single Point Entry is the current security setting and a door other than the driver's door is opened first, all doors will unlock.*

SMART KEY CHECK

If the ignition is on or the engine is running and there is no Smart Key inside the vehicle when the last door is closed, the message **Smart Key Not Found Refer to Handbook** will be displayed in the message centre.

- ⚠ Ensure that the Smart Key is in the vehicle before it is driven to another location. Without the Smart Key, if the ignition is turned off, it cannot be turned on again.

If only the ignition is on and the Smart Key is removed from the vehicle and the driver's door is the last to be closed, the ignition will switch off.

Note: *The engine cannot be started without the Smart Key inside the vehicle.*

DISARMING IF THE SMART KEY AND KEYLESS ENTRY FAIL

The vehicle can still be unlocked and the alarm disabled. To unlock the vehicle:-

1. Unlock the left front door using the key blade. The alarm will be triggered.
2. Position the Smart Key against the underside of the steering column cover with the buttons facing downwards.

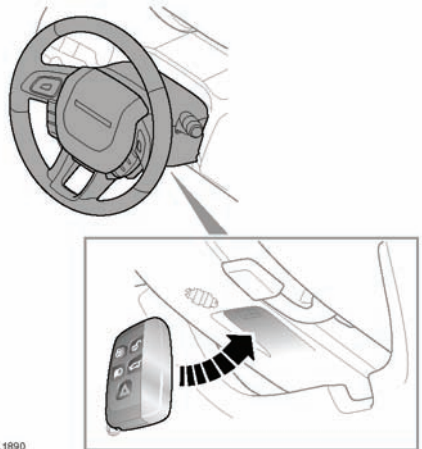

3. Now press the START/STOP button.