

UNDER BONNET COVERS - REMOVAL

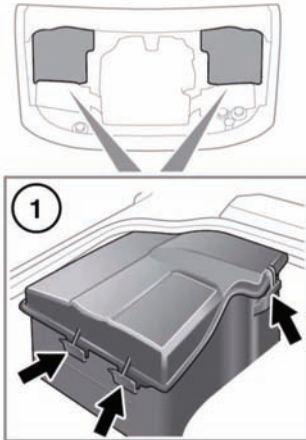

E134967

1. Press the tabs to release the cover from the casing.

Note: Releasing the inboard tab on the front edge of the cover first will make it easier to release the remaining tabs.

2. Lift the front edge of the cover and slide forwards to remove.

UNDER BONNET COVERS - REFITTING

- ⚠ Before refitting the underbonnet covers, ensure that no pipes, cables or other items, have been trapped between the cover and casing.

1. Slide the rear edge of the cover under the rubber trim fitted to the scuttle panel.
2. Make sure the front edge of the cover is flush to the casing, and then press down until the cover clicks into place.

UNBLOCKING WASHER JETS

- ⚠ **Do not operate the washer jets during unblocking or adjustment. Windscreen washer fluid may cause irritation to the eyes and skin. Always read and observe the washer fluid manufacturers instructions.**

If a washer jet becomes blocked, use a thin strand of wire to unblock the jet by inserting the wire into the jet. Ensure that the wire is completely removed after unblocking. The washer jet position may also be adjusted by inserting the point of a needle into the jet and gently repositioning it.

CHANGING A BULB

- ⚠ Before attempting a bulb change, ensure that the ignition and the affected lamp are turned off.
- ⚠ Always replace bulbs with the correct type and specification. If you are in any doubt contact your Land Rover Dealer/Authorised Repairer for advice.

Note: In certain territories it is a legal requirement to carry spare bulbs. A replacement bulb kit is available as an approved accessory from your dealer.

Note: After replacing a headlamp bulb, headlamp alignment should be checked with the appropriate equipment.