

USING VOICE CONTROL

Note: The voice system has been designed to recognise a number of languages. However, Land Rover cannot guarantee the system will be compatible with every accent group within those languages. Please speak to your Dealer/Authorised Repairer about testing the Voice System for compatibility with a particular accent group.

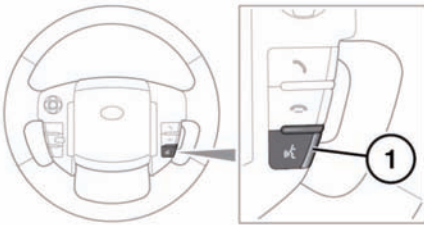

E142207

1. Voice button: Press briefly to start a voice session. A pop up will appear on the touch screen. Press and hold to cancel a voice session.

Note: Briefly press the Voice button during a voice session, to interrupt audible feedback. Wait for the tone to sound before giving the next command.

2. Voice symbol: Indicates that a command is available. Wait for the symbol to appear and a tone to sound before using the command.
3. Command list: Appears on the pop up panel, providing feedback and available commands at each stage of the voice session. Say an available command.

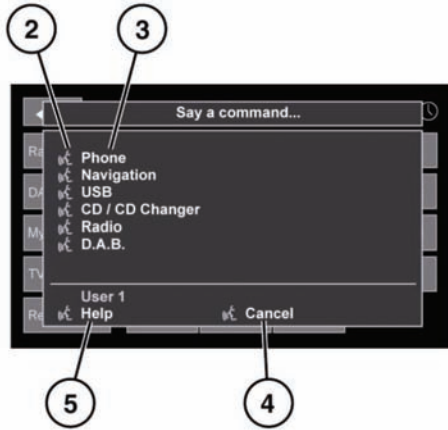

Note: As the commands are listed before the system is ready to listen, it is important to wait for the voice symbol to appear alongside the relevant command, before using the command.

4. When displayed, say **Cancel** to cancel the current voice session.
5. When displayed, say **Help** to get assistance during a voice session.

Note: The currently selected user (User 1 or User 2) is identified at the bottom of the command list.

Note: If a listed item is longer than the available space on the menu, ...> will appear. Use the seek controls on the steering wheel to view the entire entry. See **108, AUDIO/VIDEO CONTROLS**.