

SINGLE LOCKING

Press the lock button on the remote control briefly to single lock the vehicle. The hazard warning lamps will flash to confirm. Single locking secures the vehicle and prevents the doors from being opened from outside. The doors may still be unlocked and opened from inside the vehicle. In this state, only the perimeter alarm is activated.

Note: *The fuel filler flap can only be opened when the vehicle is unlocked.*

PERIMETER ALARM

When activated, the perimeter alarm will sound if:

- The bonnet, tailgate or a door are opened.
- The vehicle battery is disconnected.
- An attempt is made to disconnect the alarm siren.

Note: *This setting should be used in circumstances such as travelling on a ferry, when pets are to be left in the vehicle, or if a window must be left open etc.*

DOUBLE LOCKING



Never double lock the vehicle with people, children, or pets inside. In the event of an emergency they would be unable to escape and the emergency services would be unable to release them quickly.

Press the lock button twice briefly to double lock the vehicle. Double locking secures the vehicle and prevents the doors being opened from inside or outside of the vehicle. The doors cannot be unlocked or opened from inside the vehicle when double locked.

This provides additional security if the vehicle is left unattended. The vehicle cannot be opened by breaking a window and operating the door locks from inside.

Additionally, double locking also activates the full alarm system.

Note: *The fuel filler flap can only be opened when the vehicle is unlocked.*

FULL ALARM

When activated, the full alarm will sound if:

- The bonnet, tailgate or a door are opened.
- Movement is detected within the vehicle interior.
- A window, front or rear windscreen or sunroof glass are broken.
- The vehicle is raised or tilted.
- The vehicle battery is disconnected.
- An attempt is made to disconnect the alarm system.

Note: *In this state, an open window or sunroof will cause the alarm to sound due to the movement of air currents. For this reason, ensure all windows and the sunroof are fully closed before double locking the vehicle.*

GLOBAL CLOSING



Ensure that no children, pets, or obstructions are in any open aperture before operating global closing. Safety mechanisms are in place to prevent serious injury, however injuries can still occur.

Note: *For safety reasons the sunroof does not close automatically. It should be closed in the normal way before exiting the vehicle.*

Press and hold the lock button for 3 seconds. The vehicle will single lock and the full alarm will be activated immediately. After 3 seconds any open windows will be closed.

DOOR LOCKS AND RELEASE LEVERS

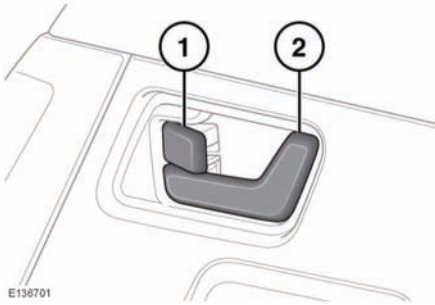

From inside the vehicle, all the doors can be locked by pressing either the driver or passenger lock lever (1).

Each rear door can be individually locked by pressing the appropriate locking lever.

To unlock and open a front door, pull the door handle (2). To unlock and open a rear door, first operate the lock lever, then pull the door handle.

MISLOCK

When attempting to lock the vehicle, if one or more of the doors, the bonnet or the tailgate are not fully closed, the vehicle will fail to lock and the horn will sound. The vehicle will not fully lock until all doors, the bonnet and the tailgate are completely closed.