

# Load Carrying

## LUGGAGE ANCHOR POINTS

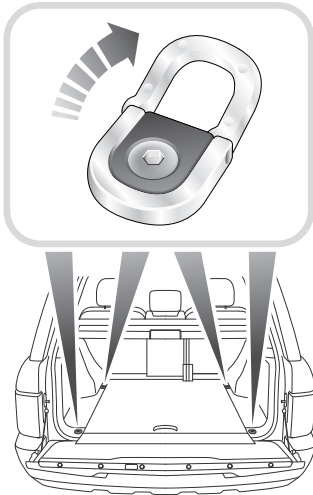

H4185

Four fixing points are provided in the rear luggage compartment floor, to assist in safely securing large items of luggage. Land Rover provide a range of approved luggage retention accessories.

### WARNING



**Do not carry unsecured equipment, tools or luggage which could move and cause personal injury in the event of an accident or emergency manoeuvre either on or off-road.**

## ROOF RACKS

A range of roof rack systems is available as Land Rover approved accessories. For further information about roof rack systems approved for use with your vehicle and advice as to which system would suit your requirements best, please consult your Land Rover Dealer/Authorised Repairer.

**Always observe the following precautions:**

- The **maximum** load for approved roof rack systems is 100 kg (220 lb) for normal road use and 50 kg (110 lb) off-road. The above weights include the mass of the roof rack system.
- Only fit roof racks that have been designed for your vehicle. If in doubt, consult your Land Rover Dealer/Authorised Repairer.
- All loads should be evenly distributed, side to side, with any weight bias towards the front of the roof rack system.
- Ensure all loads are secured within the periphery of the roof rack system.
- Check to ensure the roof rack and load are secure after 50 km (30 miles) of any journey.

### WARNING



**To avoid the risk of personal injury or death, do not permit children or any other person to travel on the roof rack (or access ladder) whilst the vehicle is in motion.**



**A loaded roof rack can reduce the stability of the vehicle, particularly when cornering and encountering cross winds.**



**Driving off-road with a loaded roof rack is not recommended. If it is necessary to stow luggage on the roof rack while driving off-road, all loads must be removed before traversing side slopes.**