

## WHEEL CHANGING SAFETY

Before raising the vehicle or changing a wheel, ensure that you read and comply with the following warnings.

### **⚠WARNING**

Always find a safe place to stop, off the highway and away from traffic.

Ensure that the vehicle and jack are both on firm level ground. Do not jack the vehicle if it is over a metal grating or manhole cover.

Apply the parking brake and engage Park (P).

Ensure the air suspension is set to off-road height.

Switch on the hazard warning lamps.

Ensure that the front wheels are in the straight ahead position.

Disconnect trailer from vehicle.

Ensure that all passengers and animals are out of the vehicle and in a safe place, away from the highway.

Place a warning triangle at a suitable distance behind the vehicle, facing towards oncoming traffic.

Never place anything between the jack and the ground, or between the jack and the vehicle.

Always position the jack from the side of the vehicle, in line with the appropriate jacking point.

Always use the complete jacking lever assembly throughout the tire changing process, to minimize any chance of accidental injury.

Take care when loosening the wheel nuts. The wheel brace may slip off if not properly attached and the wheel nuts may give way suddenly. Either unexpected movement, may cause an injury.

Take care when lifting the spare wheel, and removing the punctured wheel. The wheels

are heavy, and can cause injuries if not handled correctly.

After wheel changing, always secure tools, chocks, jack and replaced wheel in their correct stowage positions. Such objects, if not properly stowed, can become flying missiles in a crash or rollover, potentially causing injury or death.

## TOOL KIT

*Note: Tool types and positions may vary from the illustrations.*

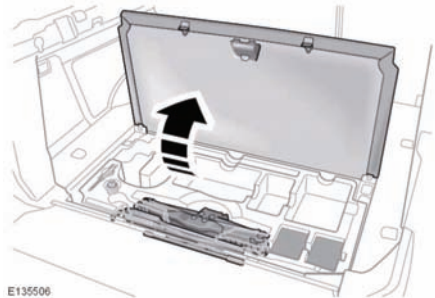

**5-seat vehicles:** The tool kit is located under a panel set in the loadspace floor.

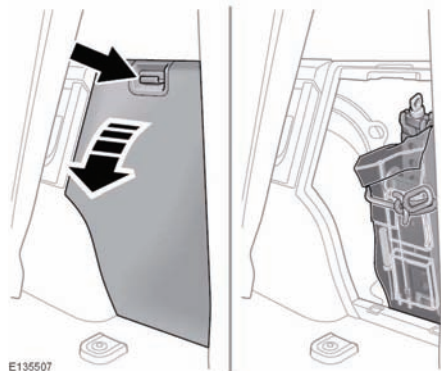

**7-seat vehicles:** The tool kit is stowed behind an access cover in the loadspace area.

## Wheel changing

**Note:** Take careful note of the stowage position for each tool, as it is important to return them to their correct position after use.

### REMOVING THE SPARE WHEEL

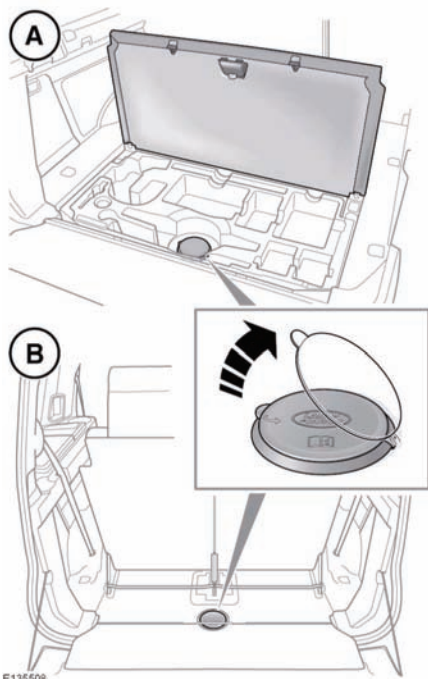

E135508

### **⚠**WARNING

Remove the spare wheel prior to jacking the vehicle, to avoid destabilizing the vehicle when raised.

The spare wheel is heavy and if handled incorrectly may cause injury. Use extreme caution when lifting or maneuvering the wheels.

Secure the spare wheel (or the removed wheel) in the correct position using the retaining bolt.

Always remove the spare wheel before jacking the vehicle. On 5-seat vehicles (A) the spare wheel lowering winch is under the rear loadspace floor. On 7-seat vehicles (B) the winch is directly under a cover behind the 3rd row seats.

**Note:** Before removing the spare wheel, take note of its stowage position. The wheel to be changed must be correctly stowed in its place.

Open the spare wheel access hatch in the loadspace area.

5-seat vehicles - remove the vehicle jack from the tool tray.

Lift the cap covering the spare wheel hoist winch nut.

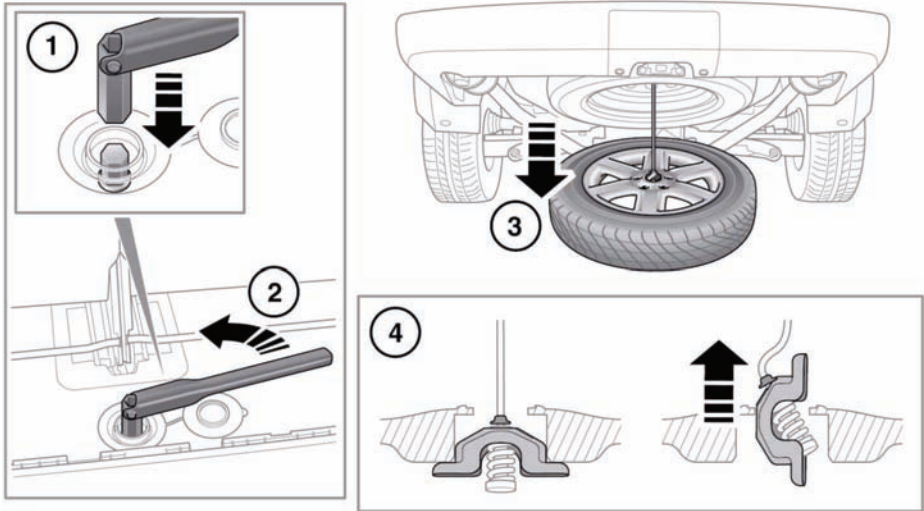

E135174

## **NOTICE**

*Do not use power tools to lower the spare wheel. Doing so may damage the mechanism.*

1. Fit the wheel nut brace to the wheel hoist winch nut.
2. Rotate the wheel nut brace counter-clockwise to lower the spare wheel.
3. Continue to turn the wheel hoist winch nut, until the wheel is on the ground and the hoist cable is slack. Do not attempt to turn the winch nut past its physical stop.
4. Hold the cable and tilt the lifting lug until it can be passed through the hole in the wheel, as shown.

## USING WHEEL CHOCKS

### **⚠ WARNING**

Always chock the wheels using suitable wheel chocks. Place the chocks on both sides of the wheel diagonally opposite the wheel to be changed.

### **⚠ WARNING**

If jacking the vehicle on a slight slope is unavoidable, place the chocks on the downhill side of the two opposite wheels.

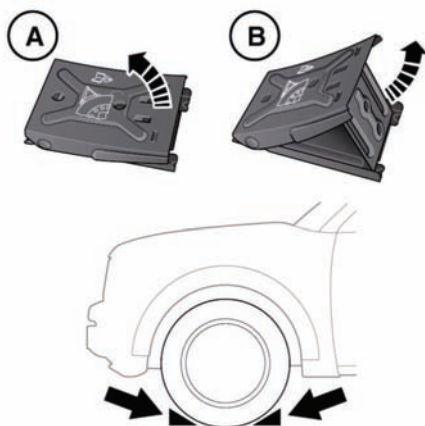

E135175

Wheel chocks are stowed in the tool kit.

1. Remove the chocks from the tool kit and lift the folded section (A) to assemble chock.
2. Lift support section (B) of chock until it locks into place.
3. Position the vehicle on level ground.

Both chocks must be used. Position them on opposite sides of the wheel and fully push them home against the tire.

**Note:** If jacking the vehicle on a slope is unavoidable, place the chocks on the downhill side of both wheels on the axle not being raised.

## JACKING POINTS

### **⚠WARNING**

The jack is designed for wheel changing only. Never work beneath the vehicle with the jack as the only means of support. Always use correctly rated vehicle support stands, before putting any part of your body beneath the vehicle.

### **NOTICE**

Only jack the vehicle using the jacking points described, or damage to the vehicle could occur.

## OPERATING THE JACK

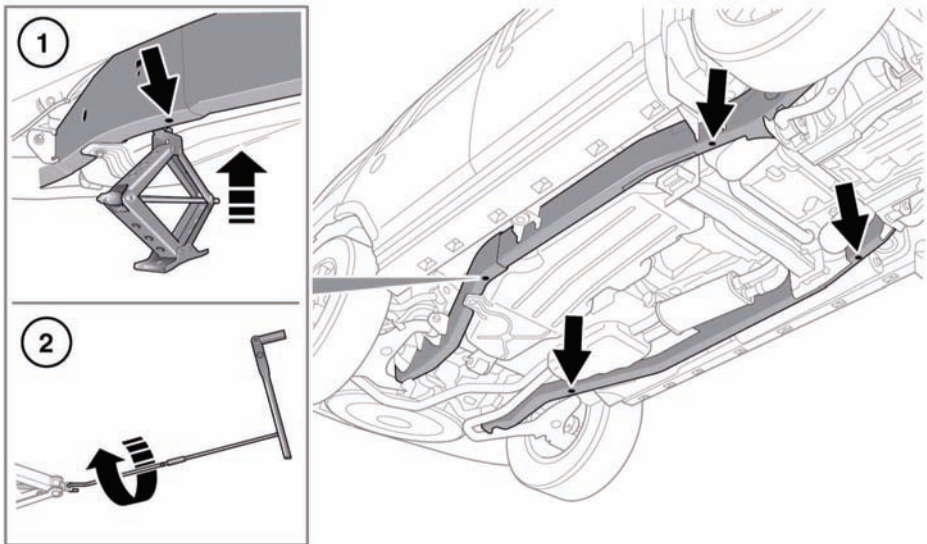

E135321

1. Locate the jack under the recommended jacking point.
2. Attach the cranking lever to the jack using the adaptor. Fit the wheel nut brace to the end of the cranking lever and rotate clockwise to raise the vehicle.

# Wheel changing

## LOCKING WHEEL NUTS

Locking wheel nuts can only be removed and installed using the special adapter provided in the tool kit.

**Note:** When the vehicle is first supplied, the adapter may be stored in the glove compartment. It should be removed and stored in the tool kit as soon as possible.

**Note:** A code number is stamped onto the underside of the adapter. This number must be recorded on the security card supplied with the literature pack. If a replacement adapter is required, you will be asked to quote this number. The security card must be kept safe, but should not be kept with the vehicle.

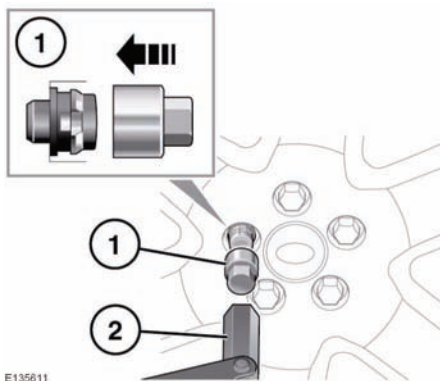

To release:

1. Insert the wheel nut adapter into the locking wheel nut, ensuring that it is fully engaged.
2. Use the wheel brace to turn the wheel nut and adapter.

**Note:** After use store the wheel nut adapter correctly in the tool kit.

## WHEEL CHANGING

1. Read and observe the warnings in **Wheel changing safety**.

2. Before raising the vehicle, use the wheel nut brace to slacken the wheel nuts half a turn counter-clockwise.
3. Position the jack under the relevant jacking point under the chassis.
4. Turn the jack lever clockwise to raise the jack cradle until it engages with the jacking point. Ensure that the base of the jack is in full contact with the road surface.
5. Raise the vehicle using the jack with a slow steady operation. Avoid rapid, jerky actions as they may cause the vehicle/jack to become unstable.
6. Remove the wheel nuts and place them together where they cannot roll away.
7. Remove the wheel and place to one side. Do not lay the wheel on its face, as this may damage the finish.
8. Fit the spare wheel to the hub.
9. Re-fit the wheel nuts, and lightly tighten them. Ensure that the wheel is making contact with the hub evenly.
10. Ensure that the space under the vehicle is clear of obstructions, and lower the vehicle slowly and smoothly.
11. With all wheels on the ground and the jack removed, fully tighten the wheel nuts. The wheel nuts must be tightened in sequence (see illustration) to the correct torque of 98 lb.ft (133 Nm).

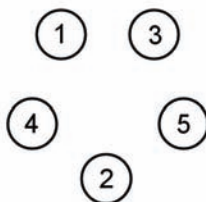

**Note:** If it is not possible to torque the wheel nuts when a wheel is replaced, they should be set to the correct torque as soon as possible.

If an alloy spare wheel is to be fitted, using a suitable blunt tool, knock the center cap out of the removed wheel. Using hand pressure only, press the center cap into the newly fitted spare.

Check and adjust the tire pressure as soon as possible.

## IMPORTANT – USE OF SPARE TIRE

### ⚠ WARNING

Adhere to the instructions on the temporary spare warning label, affixed to the wheel.

### ⚠ WARNING

When fitted the temporary use spare wheel is **FOR TEMPORARY USE ONLY**. Drive with caution while the temporary spare wheel is fitted. Ensure that an original size wheel and tire are fitted as soon as possible.

### ⚠ WARNING

Do not fit more than one temporary spare wheel on the vehicle at any one time.

### ⚠ WARNING

Do not exceed 50 mph (80 km/h) while the temporary spare wheel is fitted.

### ⚠ WARNING

The tire pressure in the temporary spare wheel should be 60 psi (4.2 Bar/420 kPa).

### ⚠ WARNING

DSC must be switched on while the temporary spare wheel is in use.

### ⚠ WARNING

Traction devices such as snow chains cannot be used with a temporary spare wheel.

## STOWING THE CHANGED WHEEL

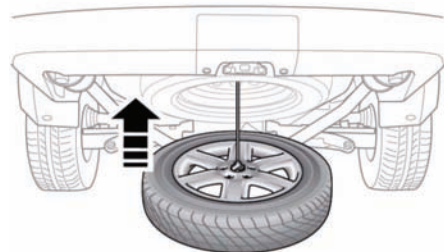
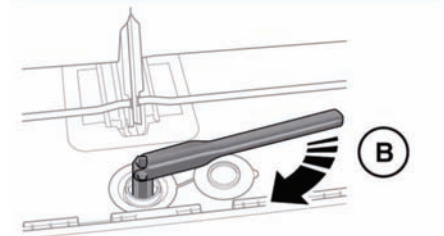
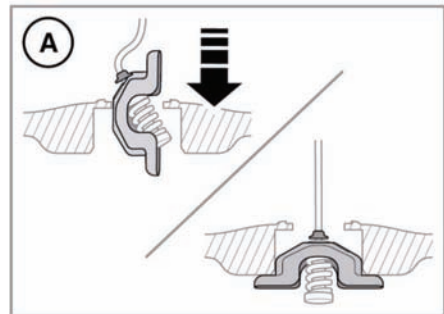

E135176

### ⚠ WARNING

Do not stow the wheel while the vehicle is raised on the jack.

### NOTICE

Do not use power tools to raise the spare wheel. Doing so may damage the mechanism.

1. Place the wheel under the vehicle with the styled face uppermost.

## Wheel changing

2. Place the lifting lug through the center of the wheel, as shown, and locate it in position **(A)**.
3. Winch up the wheel using the wheel-hoist mechanism **(B)**.
4. Continue to wind up, until the mechanism reaches its upper position. This is indicated by clear physical jerk from the wheel nut brace and an audible noise.
5. Check that the wheel has returned to the same position as the spare wheel was in before it was removed. If in any doubt, lower the winch slightly, adjust the wheel position and repeat step 4.

The wheel **must** be securely retained in its correct position by the winch mechanism, or it could become loose.

6. Replace the locking cap over the wheel hoist nut. As the underside of the cap is exposed to the same conditions as the underside of the vehicle, ensure that it is firmly in place.

**Note:** *If for any reason, the spare wheel is not to be fitted back in its hoist, the wheel hoist should be rewound as follows.*

*Position the lifting lug level on the cable, and wind up the hoist mechanism until it reaches its uppermost position. This is indicated by a clear physical jerk from the wheel nut brace and an audible noise.*