

DISABILITY MODIFICATIONS

⚠WARNING

Occupants with disabilities that may require the vehicle to be modified must contact a Land Rover Retailer/Authorized Repairer before any modifications are made.

Modifications may adversely affect the vehicle which can lead to loss of control, resulting in a crash.

(USA only) If you are considering modifying your vehicle in any way to accommodate a disability, for example by altering or adapting the driver's or passenger's seat(s) or air bag system, please contact:

Jaguar Land Rover North America
Customer Relations Center
555 MacArthur Blvd

Mahwah

New Jersey 07430-2327

1-800-637-6837, option #9.

PARTS AND ACCESSORIES

⚠WARNING

The fitting of non-approved parts and accessories, or the carrying out of non-approved alterations or conversions, may be dangerous and could affect the safety of the vehicle and occupants and also invalidate the terms and conditions of the vehicle warranty.

⚠WARNING

Land Rover will not accept any liability for death, personal injury or damage to property which may occur as a result of fitment of non-approved accessories or the carrying out of non-approved conversions to Land Rover vehicles.

AIR BAG SYSTEM

⚠WARNING

The components that make up the air bag system are sensitive to electrical or physical interference, either of which could easily damage the system and cause inadvertent operation or a malfunction of the air bag module.

⚠WARNING

Certain components of this vehicle such as air bag modules and seat belt pretensioners may contain Perchlorate Material - Special handling may apply for service or vehicle end of life disposal. See www.dtsc.ca.gov/hazardouswaste/perchlorate.

To prevent malfunction of the air bag system always consult your Land Rover Retailer/Authorized Repairer before fitting any of the following:

- Electronic equipment such as a mobile phone, two-way radio or audio system.
- Accessories attached to the front of the vehicle.
- Any modification to the front of the vehicle.
- Any modification involving the removal or repair of any wiring or component in the vicinity of any of the air bag system components, including the steering wheel, steering column, instrument or facia panels.
- Any modification to the facia panels or steering wheel.

OWNER MAINTENANCE

NOTICE

Any significant or sudden drop in fluid levels, or uneven tire wear, should be reported to a qualified technician without delay.

In addition to the routine maintenance, a number of simple checks must be carried out more frequently.

DAILY CHECKS

- Operation of lamps, horn, direction indicators, wipers, washers and warning lamps.
- Operation of seat belts and brakes.
- Look for fluid deposits underneath the vehicle that might indicate a leak.

WEEKLY CHECKS

- Engine oil level.
- Engine coolant check.
- Brake fluid level.
- Power steering fluid level.
- Windshield washer fluid level.
- Tire pressures and condition.
- Operate air conditioning.

Note: *The engine oil level should be checked more frequently if the vehicle is driven for prolonged periods at high speeds.*

ARDUOUS DRIVING CONDITIONS

When a vehicle is operated in extremely arduous conditions, more frequent attention must be paid to servicing requirements.

Arduous driving conditions include:

- Driving in dusty and/or sandy conditions.
- Driving on rough and/or muddy roads and/or wading.
- Driving in extremely hot conditions.

- Towing a trailer or driving in mountainous conditions.

Contact a Land Rover Retailer/Authorized Repairer for advice.

ROAD TESTING DYNAMOMETERS (ROLLING ROADS)

It is essential that any dynamometer testing is carried out only by a qualified person, familiar with the dynamometer testing and safety procedures practiced by Land Rover Retailer/Authorized Repairers.

SAFETY IN THE GARAGE

⚠ WARNING

If the vehicle has been driven recently, do not touch the engine, exhaust and cooling system components until the engine has cooled.

⚠ WARNING

Never leave the engine running when the vehicle is in a garage. Exhaust gases are poisonous and can unconsciousness and death if inhaled.

⚠ WARNING

Do not work beneath the vehicle with the wheel changing jack as the only means of support.

⚠ WARNING

Keep your hands and clothing away from drive belts, pulleys and fans. Some fans may continue to operate after the engine has stopped.

⚠ WARNING

Remove metal wrist bands and jewellery, before working in the engine compartment.

⚠ WARNING

Do not touch electrical leads or components while the engine is running, or with the ignition turned on.

⚠ WARNING

Do not allow tools or metal parts of the vehicle to make contact with the battery leads or terminals.

FUEL SYSTEM

⚠ WARNING

Under no circumstances should any part of the fuel system be dismantled or replaced by anyone other than a suitably qualified vehicle technician.

⚠ WARNING

Ensure sparks and naked lights are kept away from the engine compartment.

⚠ WARNING

Wear protective clothing, including, where practicable, gloves made from an impervious material.

POISONOUS FLUIDS

Fluids used in motor vehicles are poisonous and should not be consumed or brought into contact with open wounds.

For your own safety, always read and obey all instructions printed on labels and containers.

USED ENGINE OIL

Prolonged contact with engine oil may cause serious skin disorders, including dermatitis and cancer of the skin. Always wash thoroughly after contact.



It is illegal to pollute drains, water courses or soil. Use authorized waste disposal sites to dispose of used oil and toxic chemicals.

OPENING THE HOOD

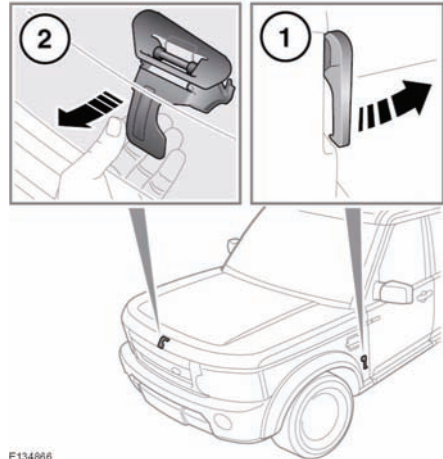

E134866

1. Pull the hood release lever, located in the left-hand front footwell.
2. Lift the hood safety catch lever, located below the center point of the hood, then raise the hood.

CLOSING THE HOOD

⚠ WARNING

Do not drive with the hood retained by the safety catch alone.

1. Lower the hood until the safety catch engages. Using both hands, press the hood down until the catches click.
2. Check that both catches are engaged, by trying to lift the front edge of the hood.

ENGINE COMPARTMENT OVERVIEW

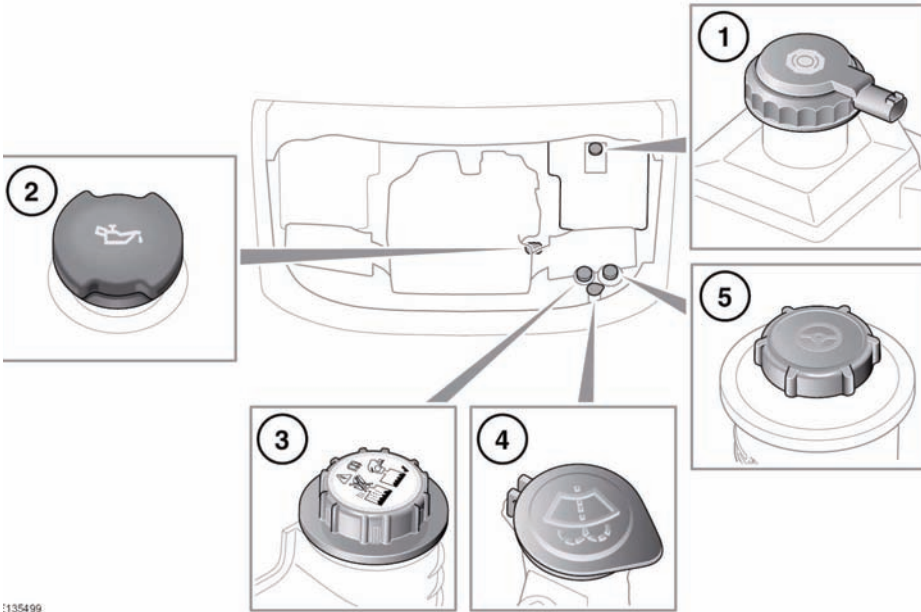

1. Brake fluid reservoir cap.
2. Engine oil filler cap.
3. Engine coolant filler cap.
4. Windshield washer fluid filler cap.
5. Power steering fluid filler cap.

⚠️WARNING

While working in the engine compartment, always observe the safety precautions. See 158, SAFETY IN THE GARAGE.

⚠️WARNING

Do not drive if there is a possibility that leaked fluid will come into contact with a hot surface, such as the exhaust.

UNDER HOOD COVERS - REMOVAL

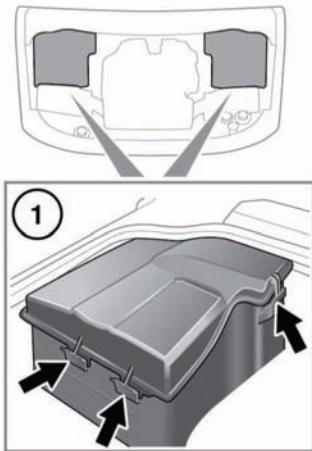

E134967

1. Press the tabs to release the cover from the casing.

Note: Releasing the inboard tab on the front edge of the cover first will make it easier to release the remaining tabs.

2. Lift the front edge of the cover and slide forwards to remove.

UNDER HOOD COVERS - REFITTING

NOTICE

Before refitting the underhood covers, ensure that no pipes, cables or other items, have been trapped between the cover and casing.

1. Slide the rear edge of the cover under the rubber trim fitted to the scuttle panel.
2. Make sure the front edge of the cover is flush to the casing, and then press down until the cover clicks into place.

UNBLOCKING WASHER JETS

CAUTION

Do not operate the washer jets during unblocking or adjustment. Windshield washer fluid may cause irritation to the eyes and skin. Always read and observe the washer fluid manufacturer's instructions.

If a washer jet becomes blocked, use a thin strand of wire to unblock the jet by inserting the wire into the jet. Ensure that the wire is completely removed after unblocking. The washer jet position may also be adjusted by inserting the point of a needle into the jet and gently repositioning it.

CHANGING A BULB

NOTICE

Before attempting to replace a bulb, ensure that both the affected lamp and the vehicle's ignition are turned off. If the circuit remains live, a short circuit can occur which may damage the vehicle's electrical system.

NOTICE

Always replace bulbs with the correct type and specification. If you are in any doubt contact your Land Rover Retailer/Authorized Repairer for advice.

Note: In certain territories it is a legal requirement to carry spare bulbs. A replacement bulb kit is available as an approved accessory from your Land Rover Retailer/Authorized Repairer.

HEADLAMP REMOVAL

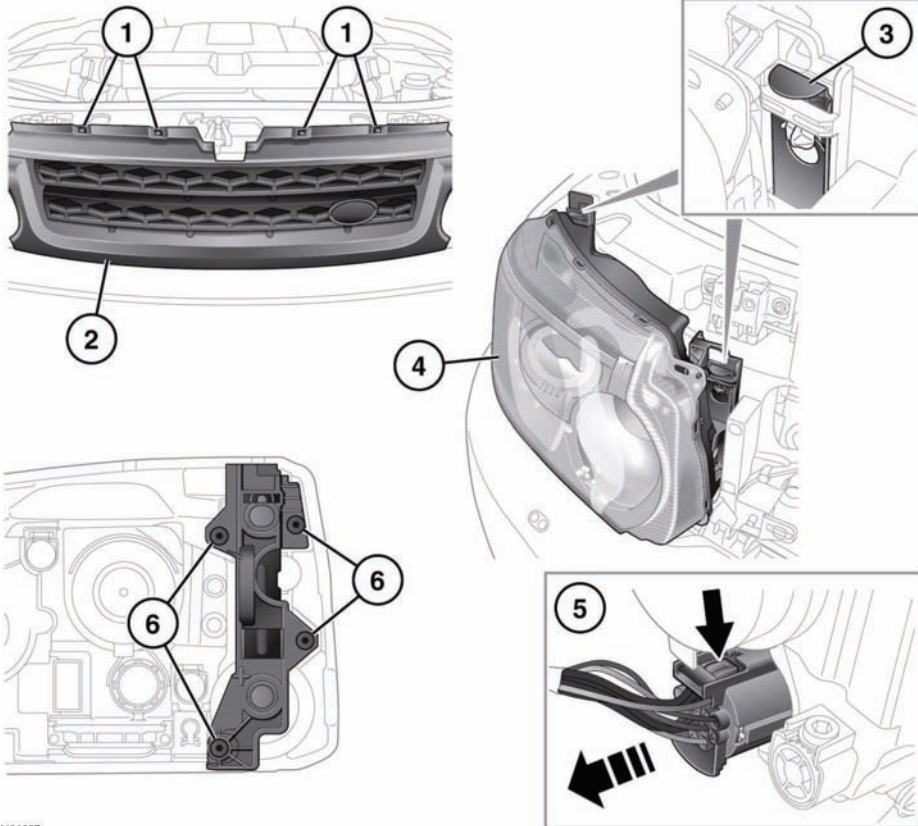

134867

⚠ WARNING

Do not attempt to change any bulb with the lighting switched on. If the lighting has just been switched off, give the bulbs time to cool down. Handling them in a hot condition may cause personal injury.

NOTICE

Do not place the removed lamp unit face down on hard or abrasive surfaces. Doing so may scratch the surface of the lens.

1. Press down on the four upper clips, and gently pulling the grill forwards.
2. Lift the grille clear of the vehicle and place where it will not be damaged.
3. Carefully lever up the locking tabs securing the rear of the headlamp. Hold the headlamp in position while doing so.

4. Holding the front of the lamp, lift forwards and clear of the body.

Note: The locking tabs (3) can be levered too far up, preventing the headlamp being released. If this happens ease the tabs down until the headlamp can be moved forward.

5. Disconnect the electrical connector from the back of the unit and remove the unit from the vehicle.

Note: Place face down on a flat surface covered in a soft material to prevent damage to the units lenses

6. To access the direction indicator, static bending lamp and side lamp, the headlamp unit locking slide assembly must be completely removed from the unit.

To remove the slide assembly, remove the four screws (arrowed). When refitting the slide, do not overtighten the screws.

Note: Refitting the headlamp unit is the reverse of removal.

HEADLAMP BULB IDENTIFICATION

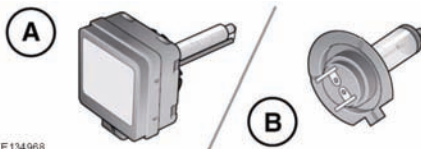

E134968

- A. Xenon bulb.
- B. Halogen bulb.

HALOGEN BULBS

Dependent on vehicle specification, halogen bulbs may be used for high beam, low beam, and front fog lamps. Take care not to touch the glass part of the bulb with your fingers; always use a cloth to handle the bulb. If necessary use methylated spirits to remove finger prints.

XENON LAMPS

⚠ WARNING

High voltage is required to ignite the gas and metal vapor which are used to power Xenon lamps. Contact with this voltage can cause serious injury. Replacement or maintenance of Xenon lamps should only be carried out by suitably qualified personnel.

⚠ WARNING

Xenon lamp units operate at a very high temperature. Ensure that the lamp units have cooled before attempting to touch them.

⚠ WARNING

Xenon lamp units contain Mercury which is highly toxic and can be extremely harmful.



Seek advice about the correct disposal of Xenon lamp units from a Land Rover Retailer/Authorized Repairer, or your local authority.

XENON HEADLAMP BULB REPLACEMENT

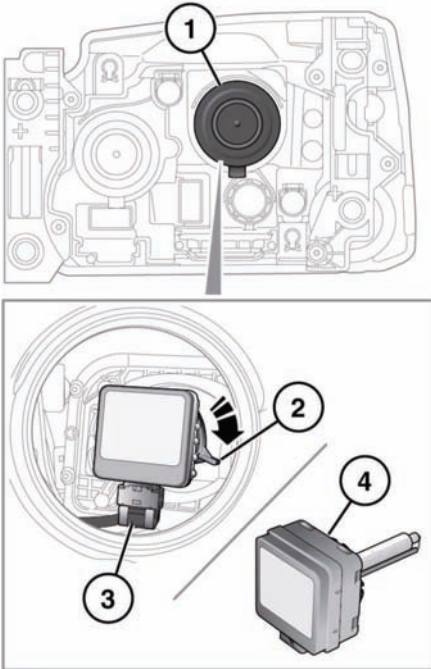

E135155

1. Twist and lift off the domed cap.
2. Rotate the collar securing the bulb to the lamp and release the bulb.
3. Pull off the electrical connector and remove the bulb.
4. Insert the new bulb unit and reverse the above procedure. Ensure that the lugs on the cap are in contact with the bulb base.

HEADLAMP BULB REPLACEMENT - HALOGEN LOW BEAM

NOTICE

Take care not to touch this type of bulb with your fingers; always use a cloth to handle them. If necessary, clean the bulb with methylated spirits to remove fingerprints.

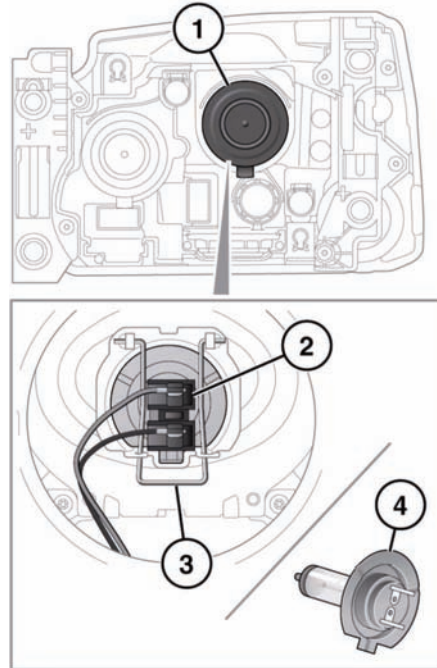

E134970

1. Twist and lift off the domed cap.
2. Pull off the electrical connector.
3. Release the spring clip securing the bulb to the lamp and remove the bulb.
4. Insert the new bulb and repeat the above procedure in reverse order.

HEADLAMP BULB REPLACEMENT - HALOGEN HIGH BEAM

NOTICE

Take care not to touch this type of bulb with your fingers; always use a cloth to handle them. If necessary, clean the bulb with methylated spirits to remove fingerprints.

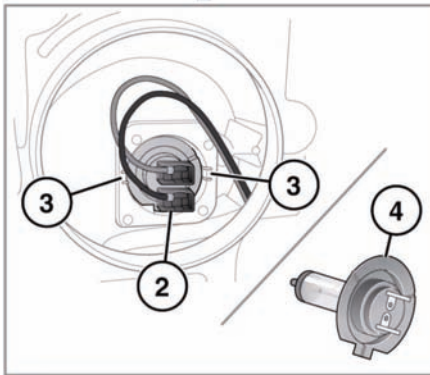
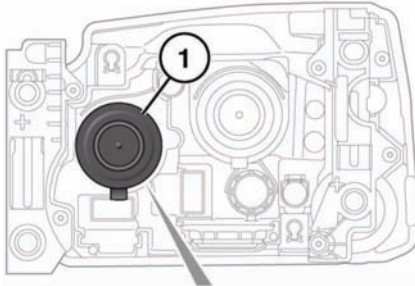

E134971

1. Twist and lift off the domed cap.
2. Pull off the electrical connector.
3. Release the bulb from the retaining tags and remove bulb.
4. Insert the new bulb and repeat the above procedure in reverse order.

SIDE LAMP BULB REPLACEMENT

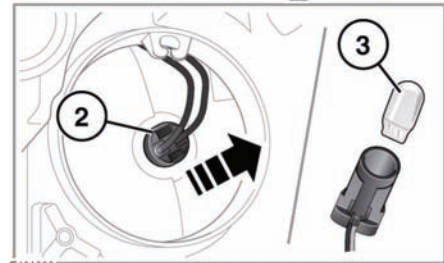
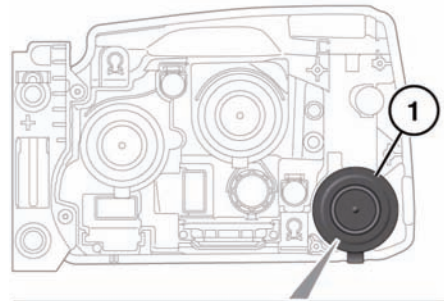

E134868

1. Twist and lift off the domed cap.
2. Press the two tabs and pull bulb holder from lamp.
3. Pull bulb from holder to remove.

FRONT FOG LAMP BULB REPLACEMENT

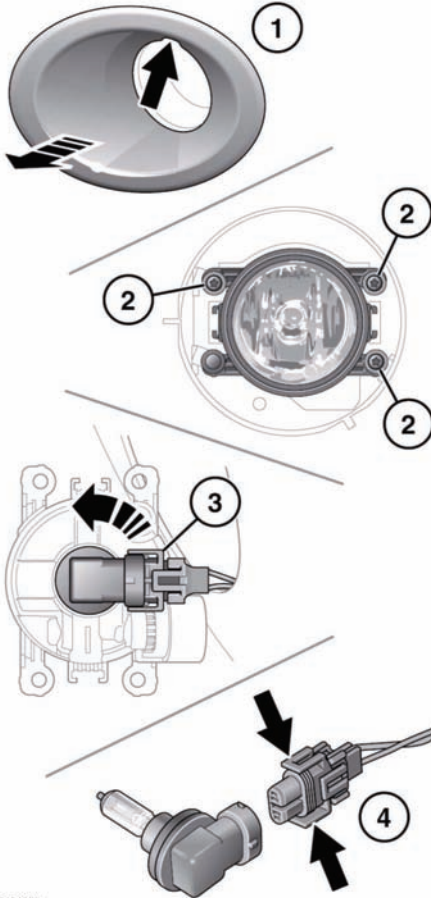

E134973

1. Using the finger slot at the top of the lamp surround, pull to remove.
2. Undo the three retaining screws, and remove the lamp unit.
3. Rotate the bulb holder (counter-clockwise) and remove from the lamp unit.
4. Press the two clips together, and remove the electrical connector.

DIRECTION INDICATOR BULB REPLACEMENT

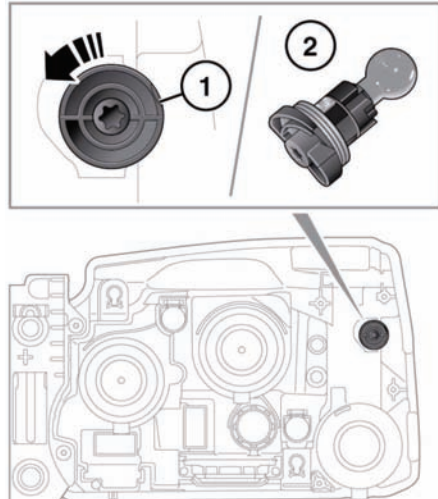

E134889

1. Rotate the bulb holder 45 degrees counter-clockwise.
2. Remove the bulb assembly from the lamp. Push and twist to remove the bulb.

REAR LAMP REMOVAL

To change any of the rear bulbs, it is necessary to completely remove the lamp unit from the vehicle.

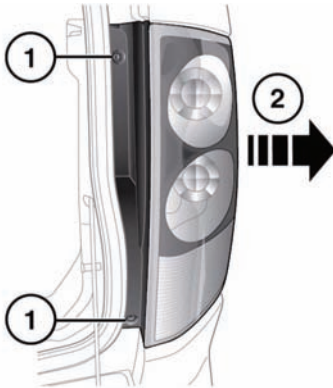

E134870

1. With the tailgate open, remove the two screws from the inner edge of the unit.
2. Pull the unit carefully away from the vehicle.
3. Disconnect the electrical connector and remove the unit from the vehicle. Place face down on a flat surface covered in soft material to prevent damage.

REAR LAMP - BULB REPLACEMENT

Note: The direction indicator lamp, stop lamp, and tail lamp are LED units, and cannot be serviced.

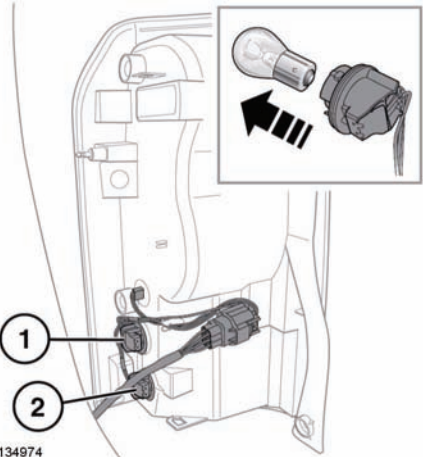

E134974

1. Reversing lamp
2. Rear fog lamp.

Twist the relevant bulb unit and pull to access the bulb. Push, twist and pull to remove the bulb.

SIDE REPEATER LAMP BULB REPLACEMENT

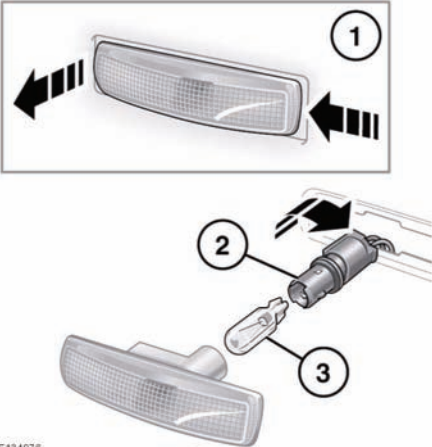

E134976

Follow the steps illustrated. Insert a new bulb and refit the components.

LICENSE PLATE LAMP BULB REPLACEMENT

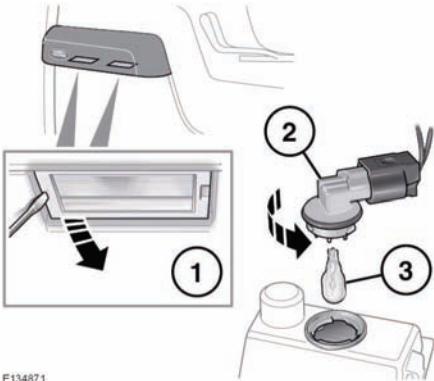

E134871

Follow the steps illustrated. Insert a new bulb and refit the components.

INTERIOR LAMP BULB REPLACEMENT

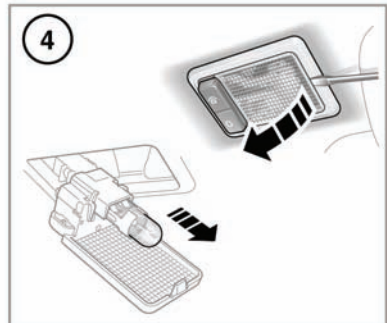
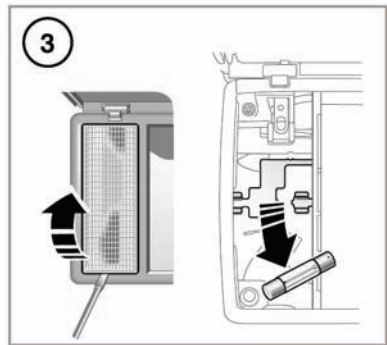
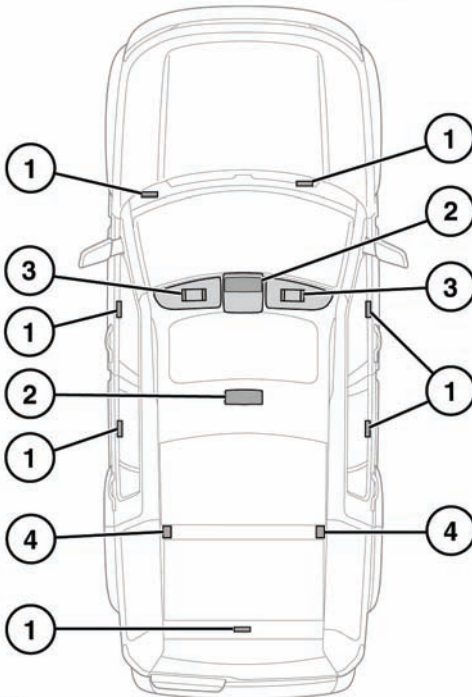
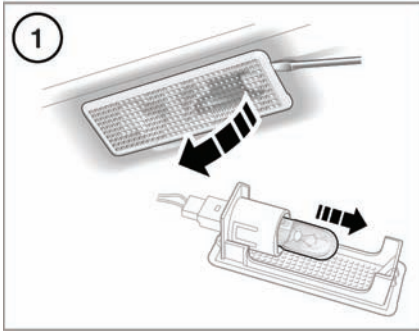

I135501

Follow the steps illustrated. Insert a new bulb and refit the components.

1. Footwell, puddle and loadspace lamps.
2. Front and rear courtesy lamps and map lamps.

3. Vanity mirror lamps.
4. Third row seat courtesy lamps.

WINDOW RESET

The windows will need to be reset if the battery is disconnected, becomes discharged or power supply is interrupted.

Reset as follows:

1. Close the window fully.
2. Release the switch, then lift it to the close position and hold for 1 second.
3. Repeat the procedure on each window.

SUNROOF RESET

If the battery is disconnected or the power supply is interrupted while the sunroof is partially open, it will need to be recalibrated.

Once the battery is reconnected or the power supply is restored, recalibrate the sunroof as follows:

1. Switch the ignition on.
2. With the sunroof closed, press and release the front of the switch. The sunroof will move to the tilted position.
3. Press the front of the sunroof switch and hold for 20 seconds.
4. After 20 seconds, the sunroof will begin to move. Keep the front of the switch pressed until the fully open/close cycle has completed.
5. Once the sunroof has stopped moving, release the switch.

The sunroof can now be operated as normal.

CLEANING THE EXTERIOR

NOTICE

Following cleaning of the vehicle exterior (particularly with a pressure washer), it is recommended that the vehicle is taken for a short drive to dry out the brakes.

NOTICE

Some high pressure cleaning systems are sufficiently powerful to penetrate door/window seals and damage trim and door locks. Never aim the water jet directly at the engine air intake, heater air intakes, body seals (doors, sunroof, windows etc.) or at any components which may be damaged (lights, mirrors, exterior trim etc.).

NOTICE

Do not use a power wash system in the engine bay area as it may cause damage.

NOTICE

Ensure that you read and comply with all warnings and product instructions supplied with any cleaning products.

NOTICE

Never use cleaning products that are not approved for use on vehicles.

NOTICE

Substances which are corrosive, such as bird droppings, can damage the vehicle's paintwork and should be removed as soon as possible.

UNDER BODY MAINTENANCE

Regularly flush the underbody with plain water, and pay particular attention to areas where mud and debris collect.

If damage or corrosion are detected, have the vehicle checked by a Land Rover Retailer/ Authorized Repairer as soon as possible.

CLEANING AFTER OFF-ROAD DRIVING

NOTICE

Ensure that the areas around air intakes and the front grille are clean and clear of debris. Pay particular attention to the lower grille and radiator. Failure to do so may cause the engine to overheat, leading to severe engine damage.

Ensure that the vehicle underside is cleaned as soon as possible after driving off-road.

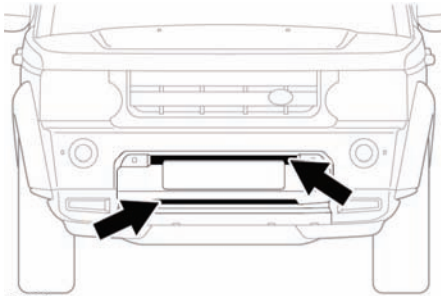

E134978

Using a hose pipe, direct clean water through the front bumper (where shown), to remove mud on the radiator and air conditioning condenser.

CLEANING THE INTERIOR

⚠ CAUTION

Some cleaning products contain substances that are harmful and can cause health problems if used incorrectly and may cause damage to the interior.

CLEANING FABRIC UPHOLSTERY

⚠ WARNING

Do not polish the instrument panel. Polished surfaces are reflective, and may interfere with the drivers view.

Clean plastic or cloth faced surfaces with warm water and non-detergent soap. Then wipe clean with a soft cloth.

CLEANING LEATHER UPHOLSTERY

NOTICE

Only use cleaning products specifically designed for use on leather. Do not use chemical, alcohol, or abrasive materials, as they will cause rapid deterioration of the leather. The use of products which are not approved will invalidate your warranty. If you are in any doubt as to which products to use, consult your Land Rover Retailer/ Authorized Repairer.

NOTICE

Some materials/fabrics are prone to dye transfer, which can cause unsightly discoloration of lighter colored leathers. Affected areas should be cleaned and re-protected as soon as possible.

Leather should be cleaned and protected at least every six months.

To prevent ingrained dirt and staining, inspect the seat upholstery regularly, and clean every 1 to 2 months as follows:

1. Wipe off fine dust from the seat surfaces using a clean, damp, non-colored cloth. Avoid over wetting the leather.
2. If this is not sufficient, use a cloth which has been dampened with warm soapy water and then wrung out. Use only mild non-caustic soap.
3. Use Land Rover leather cleaner for heavily soiled areas. Dry off and rub the with a clean soft cloth, changing surfaces regularly.

Use Land Rover leather cleaner several times a year to maintain the leather's suppleness and appearance. The cleaner will nourish and moisturize and help to improve the surface protection film against dust and substances.

- Dark clothing may stain leather seats just like other upholstery products.

- Sharp objects such as belts, zippers, rivets etc can leave permanent scratches and scratch marks on the leather surface.
- Unless spillages such as tea, coffee or ink are washed away immediately, permanent staining may have to be accepted.

If a valet service is used, ensure that the specialist concerned is aware of, and follows, these instructions precisely.

SEAT BELTS

⚠ WARNING

Do not allow any water, cleaning products, or fabric from cloths to enter the seat belt mechanism. Any substance which enters the mechanism may affect the performance of the seat belt in an impact.

Extend the seat belts fully, then use warm water and a non-detergent soap to clean. Allow the seat belts to dry naturally while fully extended.

***Note:** While cleaning the seat belt, take the opportunity to examine the webbing for damage/wear. Any wear or damage should be reported to, and rectified by, a Land Rover Retailer/Authorized Repairer.*

AIR BAG MODULE COVERS

⚠ WARNING

Air bag covers should only be cleaned using a slightly dampened cloth, and a small amount of upholstery cleaner.

⚠ WARNING

Do not allow the air bag covers, or surrounding areas, to become contaminated with liquids. Any substance which enters the mechanism can prevent correct deployment of an air bag during an impact.

CLEANING THE TOUCH SCREEN

- Clean with a lightly moistened cloth.
- Do not use chemical agents or domestic cleaners.
- To prevent errors occurring, ensure that only one finger at a time is in contact with the screen.
- Do not use excessive pressure.
- Do not allow sharp, hard or abrasive objects to make contact with the screen.
- Avoid exposing the screen to direct sunlight for long periods.