

UNLOCKING THE VEHICLE

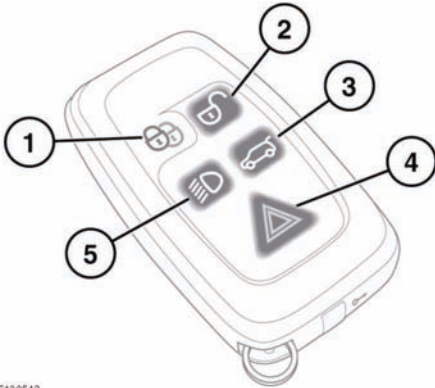

E138542

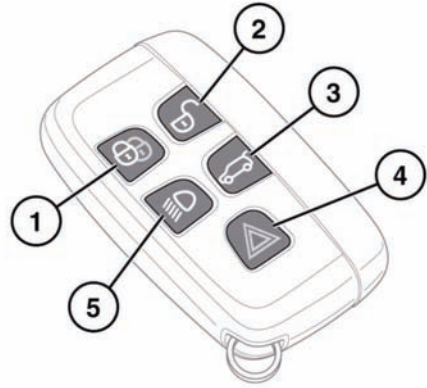

⚠ WARNING

To prevent accidental or unauthorized operation, never leave the Smart Key unattended in the vehicle. Never leave children or animals unattended in the vehicle. The vehicle can be operated when the Smart Key is inside the vehicle.

Note: There are two designs of Smart Key, refer to the information which is relevant to the design of Smart Key supplied with the vehicle.

Note: The operational range of the Smart Key will vary considerably depending on atmospheric conditions and interference from other transmitting devices.

Note: If any door or the tailgate is unlocked 10 times within a short period, the latch is disabled for approximately one minute.

The vehicle is supplied with 2 Smart Keys. The Smart Keys act as remote controls for the locking and alarm system, and allow the vehicle to be locked, unlocked and driven without the use of a conventional key. See **12, KEYLESS ENTRY, 16, KEYLESS LOCKING** and **74, STARTING THE ENGINE.**

1. Lock:

Press once to single lock the vehicle. All doors and the tailgate will lock (but can still be unlocked from inside) and the perimeter alarm will arm. See **16, LOCKING AND ARMING THE ALARM.**

2. Unlock:

Press briefly to unlock the vehicle and deactivate the alarm. The hazard warning lamps will flash twice to indicate that the vehicle is unlocked and the alarm has been deactivated. The interior lamps will illuminate to assist entry to the vehicle. Also see **12, GLOBAL OPENING.**

When you press the unlock button, your vehicle will unlock in one of two ways:

- Single Point Entry: Unlocks the driver's door only. A second press is required to unlock the remaining doors and the tailgate.
- Multi Point Entry: Unlocks all doors and the tailgate on the first press.

Single point entry can be disabled on individual Smart Keys by unlocking the vehicle then simultaneously pressing and

Entering the vehicle

holding the lock and unlock buttons for 3 seconds. The vehicle will lock and then unlock and the hazard warning lights will flash twice to confirm the change. You can now unlock all doors with a single press. Repeating the procedure will re-enable Single point entry. This feature may also be set via the **Vehicle Set-up** menu (see **55, INTERACTIVE CONTROLS**).

Note: *If a door or the tailgate are not opened within 1 minute of unlocking the vehicle, they will lock again automatically.*

3. Tailgate release:

Press briefly to release the tailgate. The vehicle security system will remain active while the tailgate is open, but intrusion and inclination sensing systems will be disabled.

On closing of the tailgate, the hazard warning lamps will flash after a few seconds to confirm the full alarm system has been reactivated (if previously armed).

4. Panic alarm:

Press and hold for 3 seconds (or press 3 times within 3 seconds) to activate the horn and the hazard lamps. The horn and hazard lamps will switch off automatically after 2 minutes and 45 seconds.

Once active for more than 5 seconds, the alarm can be cancelled by pressing the button and holding for 3 seconds (or pressing 3 times within 3 seconds).

The emergency alarm will also be cancelled if a valid smart key is present when the START/STOP button is pressed.

5. Approach lighting:

When approaching the vehicle during darkness, press to switch on the approach illumination. Press again to turn the approach lamps off.

The approach illumination period set at the factory is 30 seconds. This delay period may be configured to provide illumination lasting between 0 and 180 seconds. See the **Vehicle Set-up** menu **55, INTERACTIVE CONTROLS**.

Note: *A replacement Smart Key can only be obtained from your Land Rover Retailer/Authorized Repairer. The Retailer/Authorized Repairer will require proof of ownership.*

Notify your Land Rover Retailer/Authorized Repairer immediately if a Smart Key is lost or stolen.

Note: *The fuel filler flap can only be opened when the vehicle is unlocked.*

EMERGENCY KEY

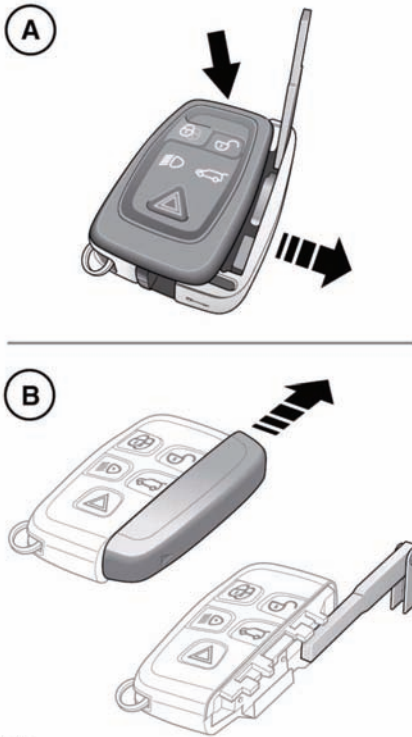

E136543

Note: There are two designs of Smart Key, refer to the information which is relevant to the design of Smart Key supplied with the vehicle.

- A.** Press emergency key release button and pull out side cover to release the key.
- B.** Slide and remove cover to expose the emergency key.

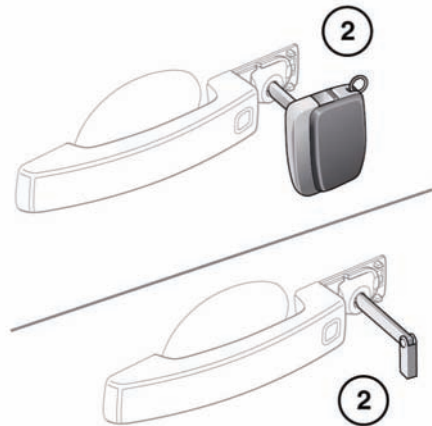
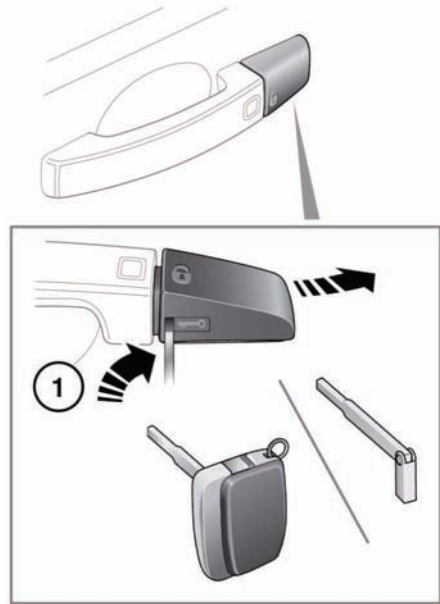

E136544

- 1.** Insert the key blade into the slot at the base of the door lock cover and gently lever the key blade upwards.
Carefully twist the key blade, to lever the cover off the retaining clips.

Entering the vehicle

2. Insert the key blade into the exposed lock to operate.

If the vehicle is unlocked using the emergency key blade with the security system armed, the alarm will sound when the door is unlocked. The alarm will continue to sound until the remote key fob is positioned correctly. See **74, IF THE ENGINE FAILS TO START.**

GLOBAL OPENING

Press and hold the unlock button for 3 seconds to unlock the vehicle and open all of the windows.

To cancel global opening, press any of the buttons on the smart key or operate the driver's window switch. To stop a particular window opening, operate the relevant window switch.

This feature can be enabled/disabled via the **Vehicle set-up** menu (see **55, INTERACTIVE CONTROLS.**

KEYLESS ENTRY

NOTICE

The Smart Key may not be detected if it is placed within a metal container or if it is shielded by a device with a back-lit LCD screen, such as a smart phone, laptop (including laptop bag), games console etc. Keep the Smart Key clear of such devices when attempting Keyless entry or Keyless starting.

Keyless entry allows the vehicle to be unlocked or disarmed, simply by operating any door handle. For keyless entry to activate, the Smart Key must be within 3 feet (1.0 m) of the door handle when it is operated. When keyless entry operates, the alarm will be disarmed and the doors unlocked according to the current security setting (single or multipoint entry). The hazard warning lamps will flash twice as confirmation (in some markets an audible warning will sound twice).

Note: *The Smart Key needs only to be on the driver's person or in a non-metallic bag or briefcase. It does not need to be exposed or handled.*

Note: *If single point entry is the current security setting, and a door other than the driver's door is opened first, the vehicle will behave as if multi-point entry is active (i.e. all doors will unlock).*

REMOTE KEY FOB SYSTEM TRANSMITTERS

⚠ WARNING

Any person fitted with an implanted medical device should be kept at a distance of at least 8.7 inches (22 cm) away from any transmitter mounted in the vehicle. This is to avoid any possibility of interference between the system and the device. Interference may cause the implanted medical device to malfunction, causing serious injury or death. For information concerning the locations of the security system transmitters, see 186, REMOTE KEY FOB TRANSMITTER LOCATIONS.

DRIVE-AWAY LOCKING

Drive-away locking automatically locks all the doors when the vehicle is in motion. This feature can be enabled/disabled via the **Vehicle Set-up** menu (see **55, INTERACTIVE CONTROLS.**

Note: *Pressing the lock or unlock button on the Smart Key will override drive-away locking for the current journey.*

OPENING AND CLOSING THE TAILGATE

NOTICE

Ensure there is minimum space of 39 in (1.0 m) above the rear of the vehicle before operating the tailgate. Insufficient space may result in damage to the vehicle.

Do not operate the tailgate if a cycle rack is fitted to the tailgate. Remove any cycles and/or racks before operating the tailgate.

There are two types of tailgate, powered and manual.

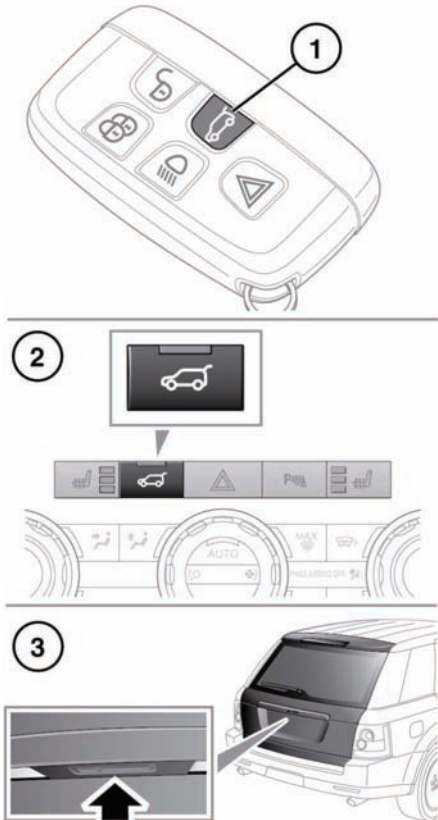

E135074

There are three possible ways to open the tailgate (powered and manual):

- Press the button on the Smart Key.
- Press the internal release switch.
- Press and release the external release switch.

NOTICE

If the Smart Key is inadvertently left inside the loadspace and the vehicle is locked and the alarm set, an audible warning will sound and the tailgate will re-open after three seconds.

Note: The tailgate will not open if the vehicle is traveling at or above approximately 3.1 mph (5 km/h).

Note: When using the external release switch, all doors must be unlocked and the gear selector in the Park (P) position.

Manual tailgate: After the tailgate is opened, lift the tailgate to the desired height.

Manually close the tailgate when required.

Powered tailgate: After the tailgate is opened to its set height, it can be manually raised or lowered. If the tailgate fails to open correctly, close it manually then press the tailgate release switch again.



E135434

Press the tailgate close switch (see above) to close the tailgate.

Entering the vehicle

As the closing tailgate reaches its lowest position, it will 'soft close' to the fully closed position. If the vehicle was previously locked, all doors will re-lock automatically to the previous locked state and the alarm will re-arm.

Note: *If a tailgate switch is pressed while the tailgate is opening or closing, all movement will stop. However, if a switch is pressed during the 'soft close' stage, the open request will be ignored.*

⚠ WARNING

Before operating the tailgate, ensure that anyone in the vicinity does not have any part of their body in a position where it could be trapped. Note that the 'soft close' action does not incorporate object detection. Death or serious injury could occur, even with an object detection system.

While the tailgate is open, the locking platform and latch are exposed. Do not manually close the latch as it may also automatically 'soft close' and trap items or body parts.

Object detection while opening: If an object is detected that would interfere with the tailgate opening, tailgate movement will stop. Remove any obstructions and press the tailgate switch again to open.

Object detection while closing: If an object is detected that would interfere with the tailgate closing, tailgate movement will stop and then reverse a short distance. An audible warning will be given to indicate a mislock. Remove any obstruction and press the tailgate switch again to close.

TAILGATE OPENING HEIGHT

It is possible to set the maximum height to which a powered tailgate will open. This is useful in parking areas with very low roofs or just for ease of use.

1. Open the tailgate to the position which you want to set as the maximum height.
Press any tailgate control to stop movement or position manually.
2. Ensure that the tailgate is stationary for at least three seconds.
3. To set the opening height: Press and hold the tailgate close button until you hear a chime.
4. Close the tailgate, then open again to check that it opens to the programed height.

Note: *If, after performing part 3 of the process the tailgate closes automatically, the required height has not been set. Repeat the process ensuring that all steps are adhered to.*

To reset the maximum opening height to full, repeat the process, but fully open the tailgate reaches its current programed height, manually move it to the fully open position before pressing and holding the button.

Programed position loss: The powered tailgate may lose its position memory if there are multiple object detections or if the battery voltage is low. Powered operation may be inhibited.

To reset the tailgate:

1. Manually close the tailgate.
2. Press a tailgate release switch.
3. Allow the tailgate to power fully open or to the previously set position.
4. Press and release the close switch.
5. Allow the tailgate to power close fully.

The tailgate programed position memory will now be restored.

REMOTE KEY FOB BATTERY REPLACEMENT

Note: There are two designs of Smart Key, refer to the information which is relevant to the design of Smart Key supplied with the vehicle.

When the battery needs renewing, there will be a significant decrease in the effective range and the message **SMART KEY BATTERY LOW** will be displayed in the message center.

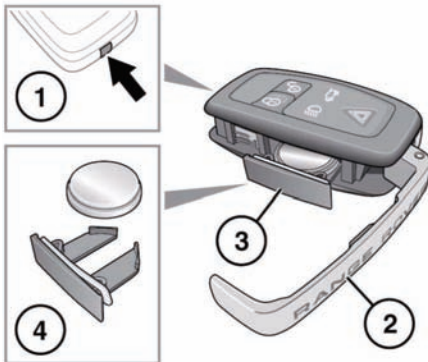

E134815

To renew the battery:

1. Press and hold the release button.
2. Open the side cover.
3. Remove the battery drawer and remove the battery.
4. Fit a new CR2032 type battery (available from your Land Rover Retailer/Authorized Repairer), with the positive (+) side upwards.

When the battery needs renewing, there will be a significant decrease in the effective range and the message **SMART KEY BATTERY LOW** will be displayed in the message center.

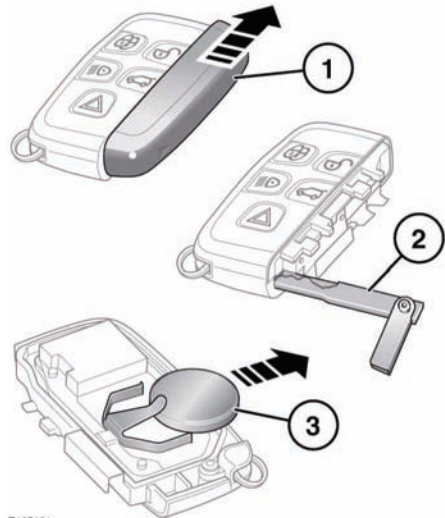

E135421

To renew the battery:

1. Slide the cover in the direction of the arrow until a click is heard. Remove the cover.
2. Use the emergency key blade to separate the Smart key body.
3. Fit a new CR2032 type battery (available from your Land Rover Retailer/Authorized Repairer), with the positive (+) side upwards.

Note: Avoid touching the new battery, as moisture/oil from fingers can reduce battery life and corrode the contacts.

Refit the parts in reverse order, ensuring that they click securely into place.



Battery disposal: Used batteries must be disposed of correctly, as they contain harmful substances. Seek advice on disposal from your Land Rover Retailer/Authorized Repairer and/or your local authority.