

Entering the vehicle

UNLOCKING THE VEHICLE

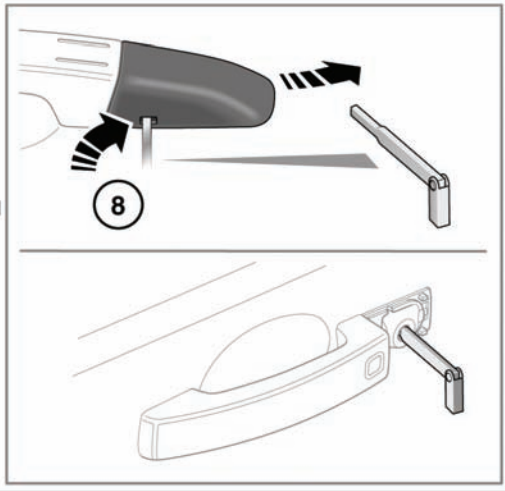
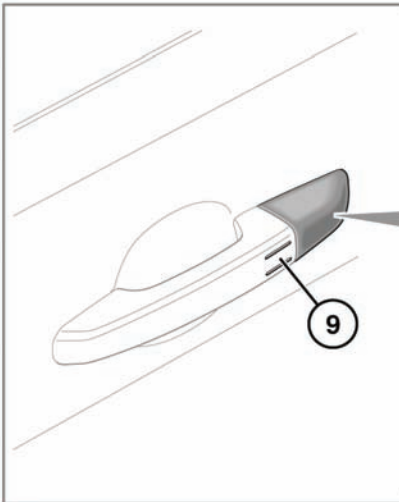
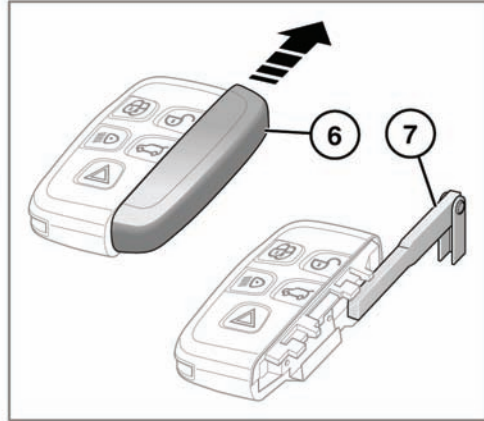
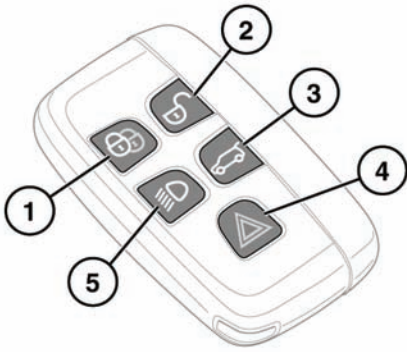

SL1811

⚠ WARNING

To prevent accidental or unauthorized operation, never leave the Smart Key unattended in the vehicle. Never leave children or animals unattended in the vehicle. The vehicle can be operated when the Smart Key is inside the vehicle.

Note: The operational range of the Smart Key will vary considerably depending on atmospheric conditions and interference from other transmitting devices.

Note: If any door or the tailgate is unlocked 10 times within a short period, the latch is disabled for approximately one minute.

The vehicle is supplied with two Smart Keys. The Smart Keys act as remote controls for the locking and alarm system and allow the vehicle to be locked, unlocked and driven without the use of a conventional key. See **10, KEYLESS ENTRY**, **17, KEYLESS LOCKING** and **80, ENGINE STARTING**. Each Smart Key also has an emergency key housed in a slide out compartment.

1. Lock:

- Press to secure the vehicle. See **16, LOCKING AND ARMING THE ALARM**.

2. Unlock:

- Press briefly to unlock the vehicle and deactivate the alarm. See **10, SINGLE-POINT/MULTI-POINT ENTRY**. The hazard warning lamps will flash twice to indicate that the vehicle is unlocked and the alarm has been deactivated. The interior lamps and puddle lamps will illuminate to assist entry to the vehicle.

See also **10, GLOBAL OPENING**.

Power fold mirrors will unfold (if enabled).

3. Tailgate release:

- Press briefly to open the tailgate. If the vehicle is locked and armed, the security system will remain active while the tailgate is open.

When closing the tailgate again, if the vehicle is already locked and armed, the hazard warning lamps will flash after a few seconds to confirm the full alarm system has been reactivated.

See **12, POWERED TAILGATE OPERATION**.

NOTICE

Ensure that the Smart Key does not remain in the vehicle prior to closure. If the vehicle is in an area of localised RF interference or the Smart Key is shielded by metal objects, the vehicle may close and lock with no means of opening again.

4. Panic alarm:

- Press and hold for 3 seconds (or press 3 times within 3 seconds) to activate the horn and the hazard lamps.
- Once active for more than 5 seconds, the alarm can be cancelled by pressing the button and holding for 3 seconds (or pressing 3 times within 3 seconds).
- The emergency alarm will also be cancelled if a valid Smart Key is present when the START/STOP button is pressed.

5. Approach lighting:

- When approaching the vehicle during darkness, press to switch on the approach illumination. Press again to turn the approach lamps off.
- The approach illumination period set at the factory is 30 seconds. This delay period may be configured to provide illumination lasting between 0 and 240 seconds. See **63, VEHICLE INFORMATION AND SETTINGS MENU**.

***Note:** In some markets a second press of the button will turn on the headlamps and reversing lamps. A third press will be required to turn the lamps off.*

6. Access to emergency key blade: Slide open the side cover.

7. Remove the emergency key blade and unfold.

Entering the vehicle

8. If the Smart Key fails to open the vehicle, insert the key blade into the slot at the base of the door lock cover and gently lever the key blade upwards. Carefully twist the key blade, to lever the cover off the retaining clips. Insert the key blade into the exposed lock and turn to operate the lock. The alarm will sound.

Note: When the left hand front door is unlocked using the key blade, the alarm will sound until the Smart Key is positioned correctly.

Note: A replacement Smart Key can be obtained only from your Land Rover Retailer. The Retailer will require proof of identification and ownership.

Notify your Retailer immediately if a Smart Key is lost or stolen.

9. Keyless entry/exit:
 - Door handles with lock sensors.

AUTOMATIC RELOCKING

If a door, tailgate or hood are not opened within 40 seconds of unlocking the vehicle via the Smart Key, all doors will re-lock automatically to the previous locked state and the alarm will re-arm.

SINGLE-POINT/MULTI-POINT ENTRY

When you press the unlock button, your vehicle will unlock in one of two ways:

1. Single Point Entry: Unlocks the driver's door only. A second press is required to unlock the remaining doors and the tailgate.
2. Multi-Point Entry: Unlocks all doors and the tailgate on the first press.

To change from Single to Multi-Point entry (or vice versa), with the vehicle unlocked, press both the lock and unlock buttons simultaneously for 3 seconds. The hazard warning lamps will flash twice to confirm the change.

This feature may also be set via the settings menu. See **63, VEHICLE INFORMATION AND SETTINGS MENU**.

Note: If, when the vehicle is unlocked, an audible warning is emitted, this will be a 'Mislock' error. There may be a fault with either of the alarm sensors. Consult with your Retailer as soon as possible.

GLOBAL OPENING

Press and hold the Smart Key unlock button for 3 seconds to unlock the vehicle and open all windows.

Press any button on the Smart Key to cancel the operation.

KEYLESS ENTRY

Keyless entry allows the vehicle to be opened if a Smart Key is within 3ft (1.0m) of the door handle or the tailgate external switch.

NOTICE

The Smart Key may not be detected if it is placed within a metal container or if it is shielded by a device with a back-lit LCD screen, such as a smart phone, laptop (including laptop bag), games console etc. Keep the Smart Key clear of such devices when attempting Keyless entry or Keyless starting.

Note: The Smart Key needs only to be on the driver's person or in a non-metallic bag or briefcase. It does not need to be exposed or handled.

When keyless entry operates, the alarm will be disarmed and the doors unlocked according to the current unlock/entry setting (Single or Multi-Point). The hazard warning lamps will flash twice as 'unlock' confirmation. Power folded mirrors will fold out (if enabled).

Note: If Single Point Entry is the current security setting and a door other than the driver's door is opened first, all doors will unlock.

SMART KEY CHECK

If the ignition is on or the engine is running and there is no Smart Key inside the vehicle when the last door is closed, the message **Smart Key Not Found Refer to Handbook** will be displayed in the message center.

NOTICE

Ensure that the Smart Key is in the vehicle before it is driven to another location. Without the Smart Key, if the ignition is turned off, it cannot be turned on again.

If only the ignition is on and the Smart Key is removed from the vehicle and the driver's door is the last to be closed, the ignition will switch off.

Note: The engine cannot be started without the Smart Key in the vehicle.

DISARMING IF THE SMART KEY AND KEYLESS ENTRY FAIL TO WORK

The vehicle can still be unlocked and the alarm disabled. To unlock the vehicle:-

1. Unlock the left side front door using the key blade. The alarm will be triggered.
2. Position the Smart Key against the underside of the steering column cover with the buttons facing downwards.

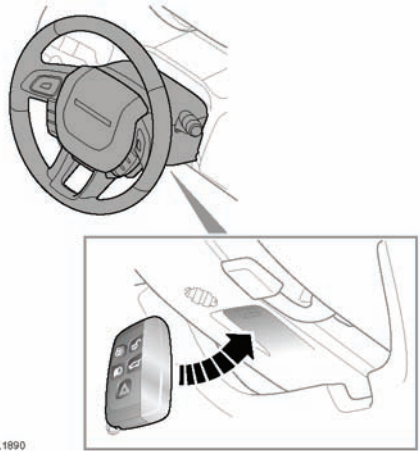

3. Now press the START/STOP button.

DEACTIVATING THE ALARM WHEN TRIGGERED

If the alarm has been triggered, it can be deactivated by any one of the following methods:

- Pressing the unlock button on the Smart Key.
- Opening a door using keyless entry.
- Positioning a valid Smart Key underneath the steering column and pressing the START/STOP button. See previous graphic.

Entering the vehicle

SMART KEY SYSTEM TRANSMITTERS

⚠ WARNING

Any person fitted with an implanted medical device should be kept at a distance of at least 8.7 inches (22 cm) away from any transmitter mounted in the vehicle. This is to avoid any possibility of interference between the system and the device. Interference may cause the implanted medical device to malfunction, causing serious injury or death. See 195, SMART KEY SYSTEM TRANSMITTERS.

DESELECTING VALET MODE

If Valet mode is active when you enter the vehicle, touch the **Valet** button to view the Valet mode screen.

Enter your four digit PIN and touch the **OK** button.

Valet mode is deactivated is displayed.

- The tailgate will return to the previously set security requirement.
- All touch screen functions are enabled.

See 17, **SELECTING VALET MODE**.

Note: If the PIN number is lost or forgotten, Valet mode can be deactivated only by your Retailer.

POWERED TAILGATE OPERATION

NOTICE

Ensure there is minimum space of 39 in (1.0M) above the rear of vehicle before operating the tailgate. Insufficient space may result in damage to the vehicle.

NOTICE

Do not operate the tailgate if a cycle rack is fitted to the tailgate. Remove any cycles and/or racks before operating the tailgate.

The tailgate can be released using:

- the appropriate button on the Smart Key,
- the internal release switch,

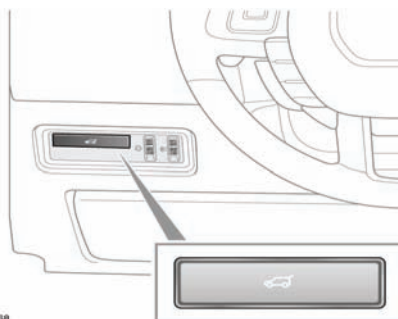

- the external release switch on the tailgate.

Using any of these methods, the powered tailgate option will open.

Note: The tailgate will not open if the vehicle is travelling at or above approximately 3.1mph (5km/h).

Note: When using the external release switch, all doors must be unlocked and the transmission in Park (**P**) position.

Note: If the Smart Key is inadvertently left inside the luggage compartment and the vehicle is locked and the alarm set, an audible warning will sound and the tailgate will re-open after three seconds.

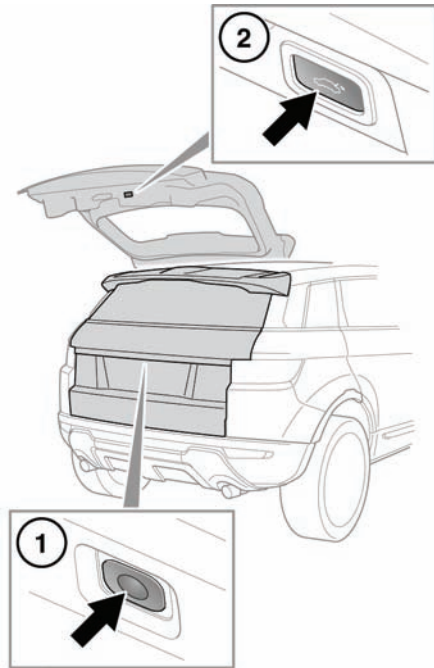

SJ1702

1. Press to open the powered tailgate.
2. Press and release to close the powered tailgate.

After the tailgate has opened to its set height, it can be manually raised or lowered. If the tailgate fails to open or close correctly, close it manually then press the tailgate release switch again.

As the closing tailgate reaches its lowest position, it will 'soft close' to the fully closed position. If the vehicle was previously locked, all doors will re-lock automatically to the previous locked state and the alarm will re-arm. The hazard warning lamps will flash to confirm the lock status. An audible confirmation may also be given.

Note: If a tailgate switch is pressed while the tailgate is opening or closing, all movement will stop. However, if a switch is pressed during the 'soft close' stage, the open request will be ignored.

⚠ WARNING

Before operating the tailgate, ensure that anyone in the vicinity does not have any part of their body in a position where it could be trapped. Note that the 'soft close' action does not incorporate object detection. Death or serious injury could occur, even with an object detection system.

Object detection while opening: If an object is detected that would interfere with the tailgate opening, tailgate movement will stop. Remove any obstructions and press the tailgate switch again to open.

Object detection while closing: If an object is detected that would interfere with the tailgate closing, tailgate movement will stop and then reverse a short distance. An audible warning will be given to indicate a mislock. Remove any obstructions and press the tailgate switch again to close.

NOTICE

While the tailgate is open, the locking platform and latch are exposed. Do not manually close the latch as it may also automatically 'soft close' and trap items or body parts.

Entering the vehicle

POWERED TAILGATE OPENING HEIGHT

The maximum opening height can be set as required. This is useful in parking areas with low ceiling heights or just for ease of use.

1. Open the tailgate to the position which you want to set as the maximum height. Press any tailgate control to stop movement at the required position. Final position can be achieved manually if required.
2. Ensure that the tailgate is stationary for at least three seconds.
3. Press and hold the tailgate close switch for ten seconds to set the maximum opening height.
4. Close the tailgate, then open again to check that it opens to the set height.

Note: If, after performing part 3 of the process the tailgate closes automatically, the required height has not been set. Repeat the process ensuring that all steps are adhered to.

To reset the maximum opening height, repeat the process, but when the tailgate reaches its current set height, manually move it to the fully open position before pressing and holding the button.

PROGRAMMED POSITION LOSS

The powered tailgate may lose its position memory if there are multiple object detections or if battery voltage is low. Powered operation may be inhibited. To reset the tailgate;

1. Manually close the tailgate.
2. Press a release switch.
3. Allow the tailgate to power fully open or to the previously set position.
4. Press and release the close switch.
5. Allow the tailgate to power close fully.

The tailgate set position memory will now be restored.

CHANGING THE SMART KEY BATTERY

When the battery needs replacing, there will be a significant decrease in the effective range and the message **SMART KEY BATTERY LOW** will be displayed in the message center.

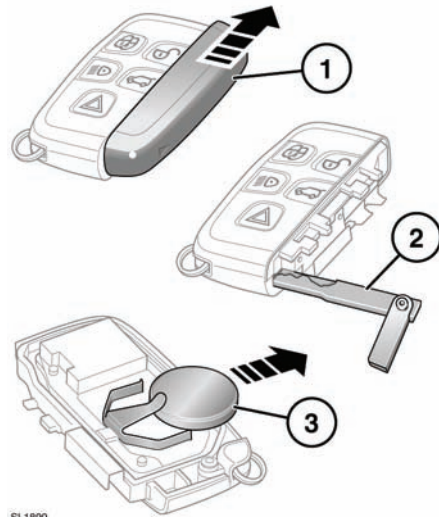

SL1899

To replace the battery:

1. Slide open the side cover.
2. Remove the emergency key and fit into the receiver.
3. With the key unfolded, twist it to split the Smart Key case open.
4. Remove the old battery and fit a new CR2032 type battery (available from your Retailer), with the positive (+) side upwards.

Note: Avoid touching the new battery, as moisture/oil from fingers can reduce battery life and corrode the contacts.

Refit the parts in reverse order, ensuring that they click securely into place.



Battery disposal: Used batteries must be disposed of correctly, as they contain harmful substances.

Seek advice on disposal from your Retailer and/or your local authority.