













Wheel changing

WHEEL CHANGING SAFETY

Before raising the vehicle or changing a wheel, ensure that you read and comply with the following warnings.

-  Always find a safe place to stop, off the highway and away from traffic.
-  Ensure that the vehicle and jack are both on firm level ground.
-  Apply the parking brake and engage Park (P).
-  Ensure the air suspension is set to off road height.
-  Switch on the hazard warning lamps.
-  Ensure that the front wheels are in the straight ahead position, and engage the steering lock.
-  Disconnect trailer/caravan from vehicle.
-  Ensure that all passengers, and animals, are out of the vehicle and in a safe place away from the highway.
-  Place a warning triangle at a suitable distance behind the vehicle, facing towards oncoming traffic.
-  Remove the spare wheel prior to jacking the vehicle, to avoid destabilising the vehicle when raised.
-  Never place anything between the jack and the ground, or the jack and the vehicle.
-  **WARNING - THAT NO PERSON SHOULD PLACE ANY PORTION OF THEIR BODY UNDER A VEHICLE THAT IS SUPPORTED BY A JACK.**
-  Take care when loosening the wheel nuts. The wheel brace may slip off if not properly attached and the wheel nuts may give way suddenly. Either unexpected movement, may cause an injury.



Take care when lifting the spare wheel, and removing the punctured wheel. The wheels are heavy, and can cause injuries if not handled correctly.

TOOL KIT

Note: Tool types and positions may vary from the illustrations.

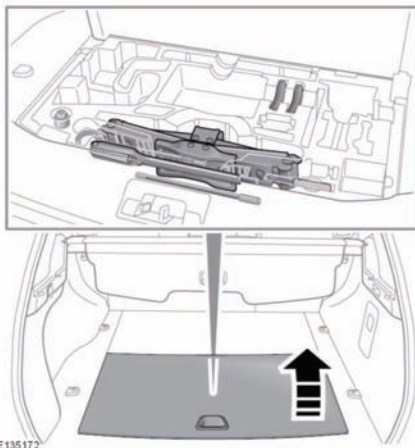



The tool kit is located under a panel set in the loadspace floor.

Note: Take careful note of the stowage position for each tool, as it is important to return them to their correct position after use.

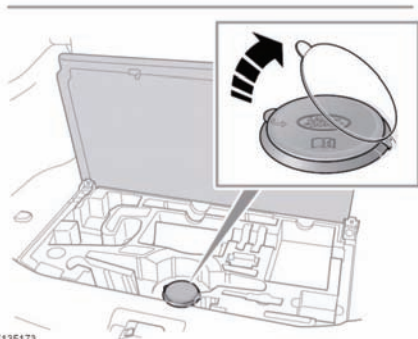
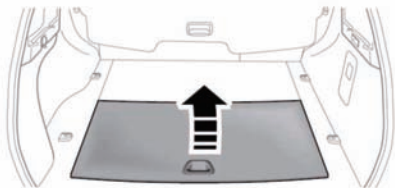
LOWERING THE SPARE WHEEL



E135173

-  **Remove the spare wheel prior to jacking the vehicle, to avoid destabilising the vehicle when raised.**
-  **Wheels are heavy and if handled incorrectly may cause injury. Use extreme caution when lifting or manoeuvring the wheels.**
-  **Always secure the spare wheel, or the removed wheel, in the correct position using the retaining bolt.**

Always remove the spare wheel before jacking the vehicle.

Wheel changing

Note: Before removing the spare wheel, take note of its stowage position. The wheel to be changed must be correctly stowed in its place.

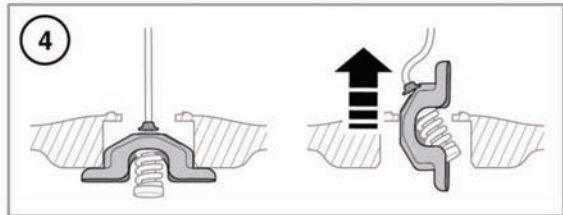
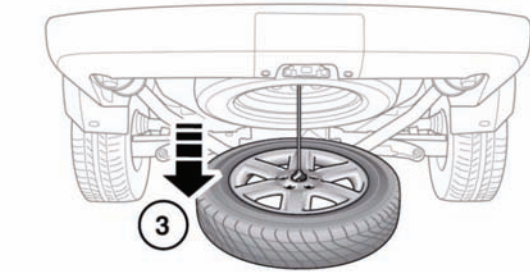
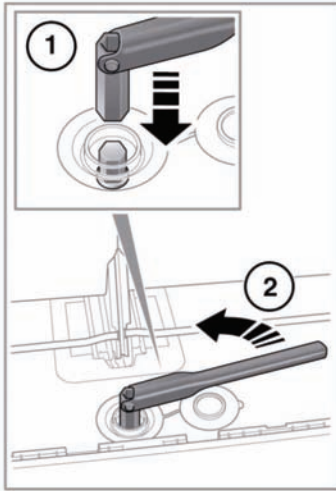



E135174

! Do not use power tools to lower the spare wheel. Doing so may damage the mechanism.

1. Open the spare wheel access hatch in the loadspace area and remove the vehicle jack from the tool tray.
Lift the cap covering the spare wheel hoist winch nut.
2. Fit the wheel nut brace to the wheel hoist winch nut, and rotate anticlockwise to lower the spare wheel.
3. Continue to turn the wheel hoist winch nut, until the wheel is on the ground and the hoist cable is slack. Do not attempt to turn the winch nut past its physical stop.
4. Hold the cable and tilt the lifting lug until it can be passed through the hole in the wheel, as shown.

USING WHEEL CHOCKS

 Always chock the wheels using suitable wheel chocks. Place the chocks on both sides of the wheel diagonally opposite the wheel to be changed.

 If jacking the vehicle on a slope is unavoidable, place the chocks on the downhill side of both wheels on the axle not being raised.

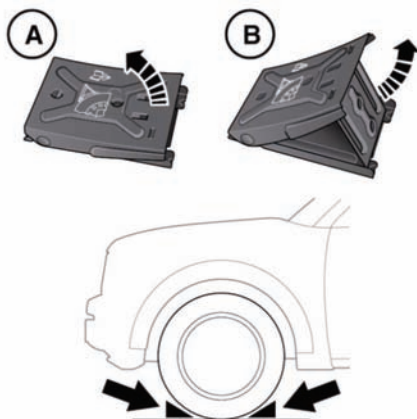

E135175

Wheel chocks are stowed in the tool kit.

1. Remove the chocks from the tool kit and lift the folded section (A) to assemble chock.
2. Lift support section (B) of chock until it locks into place.
3. Position the vehicle on level ground.
Both chocks must be used. Position them on opposite sides of the wheel and fully push them home against the tyre.

LOCKING WHEEL NUTS

Locking wheel nuts can only be removed and installed using the special adapter provided in the tool kit.

Note: A code number is stamped onto the underside of the adapter. This number should be recorded on the security card supplied with the literature pack. If a replacement adapter is required, you will be asked to quote this number. The security card must be kept safe, but should not be kept with the vehicle.

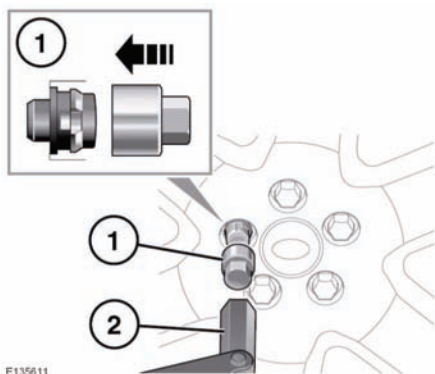

E135611

To release

1. Insert the wheel nut adapter into the locking wheel nut, ensuring that it is fully engaged.
2. Use the wheel brace to turn the wheel nut and adapter.

Note: After use store the wheel nut adapter correctly in the tool kit.

Wheel changing

JACKING POINTS

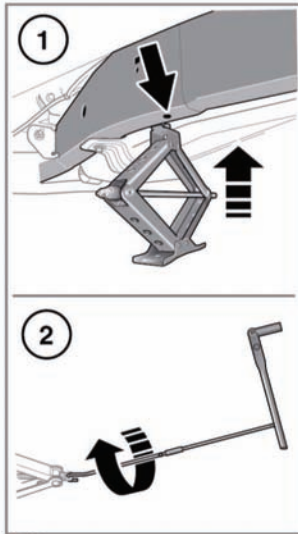

E135321

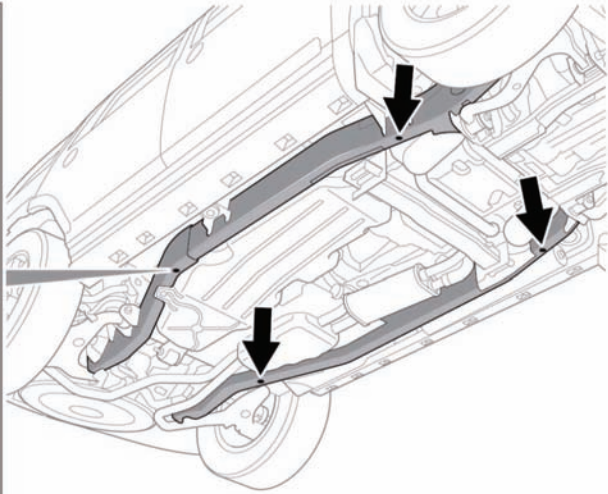

- ⚠ Only jack the vehicle using the jacking points described, or damage to the vehicle could occur.

Note: Your vehicle may be fitted with an alarm tilt sensor. To lock the doors while changing the wheel, and avoid the alarm activating, turn off the alarm sensors. See **Vehicle set-up menu 51, INTERACTIVE CONTROLS**.

OPERATING THE JACK

⚠ **WARNING - THAT NO PERSON SHOULD PLACE ANY PORTION OF THEIR BODY UNDER A VEHICLE THAT IS SUPPORTED BY A JACK.**

⚠ **WARNING - DO NOT GET UNDER A VEHICLE THAT IS SUPPORTED BY A JACK.**

1. Locate the jack under the recommended jacking point.

2. Attach the cranking lever to the jack using the adaptor. Fit the wheel nut brace to the end of the cranking lever and rotate clockwise to raise the vehicle.

WHEEL CHANGING

1. Read and observe the **WARNINGS** before changing a wheel, see **208, WHEEL CHANGING SAFETY**.
2. Before raising the vehicle, use the wheel nut brace to slacken the wheel nuts half a turn anticlockwise.
3. Position the jack under the relevant jacking point, under the chassis.
4. Turn the jack lever clockwise to raise the jack cradle until it engages with the jacking point. Ensure that the base of the jack is in full contact with the road surface.

5. Raise the vehicle using the jack with a slow steady operation. Avoid rapid, jerky actions as they may cause the vehicle/jack to become unstable.
6. Remove the wheel nuts and place them together where they cannot roll away.
7. Remove the wheel and place to one side. Do not lay the wheel on its face, as this may damage the finish.
8. Fit the spare wheel to the hub.
9. Re-fit the wheel nuts, and lightly tighten them. Ensure that the wheel is making contact with the hub evenly.
10. Ensure that the space under the vehicle is clear of obstructions, and lower the vehicle slowly and smoothly.
11. With all wheels on the ground and the jack removed, fully tighten the wheel nuts. The wheel nuts must be tightened in sequence (see illustration) to the correct torque of 133 Nm (98 lb.ft).

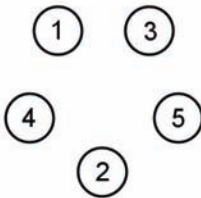

E132675

Note: If it is not possible to torque the wheel nuts when a wheel is replaced, they should be set to the correct torque as soon as possible.

If an alloy spare wheel is to be fitted, using a suitable blunt tool, knock the centre cap out of the removed wheel. Using hand pressure only, press the centre cap into the newly fitted spare. Check and adjust the tyre pressure as soon as possible.

IMPORTANT - USE OF SPARE TYRE



Adhere to the instructions on the temporary spare warning label, affixed to the wheel.



Where fitted the temporary use spare wheel is **FOR TEMPORARY USE ONLY**. Drive with caution while the temporary spare wheel is fitted. Ensure that an original size wheel and tyre are fitted as soon as possible.



Do not fit more than one temporary spare wheel.



Do not exceed 80 km/h (50 mph) while the temporary spare wheel is fitted.



The tyre pressure in the temporary spare wheel should be 420 kPa (4.2 Bar/60 psi).



DSC must be switched on while the temporary spare wheel is in use.



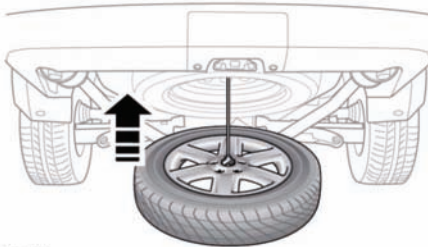
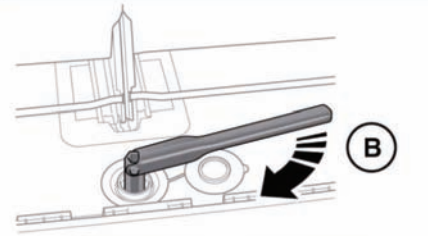
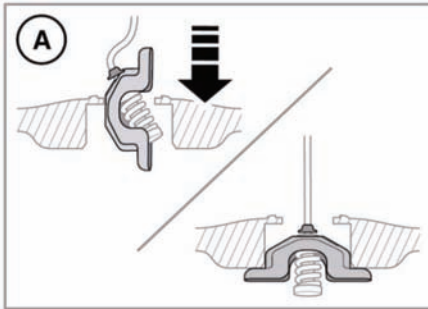

Traction devices such as snow chains cannot be used with a temporary spare wheel.

STOWING THE CHANGED WHEEL



E 135170

-  **Do not stow the wheel while the vehicle is raised on the jack.**
-  Do not use power tools to raise the spare wheel. Doing so may damage the mechanism.
1. Place the wheel under the vehicle with the styled face uppermost.
 2. Place the lifting lug through the centre of the wheel, as shown, and locate it in position (A).
 3. Winch up the wheel using the wheel-hoist mechanism (B).

4. Continue to wind up, until the mechanism reaches its upper position. This is indicated by clear physical jerk from the wheel nut brace and an audible noise.
5. Check that the wheel has returned to the same position as the spare wheel was in before it was removed. If in any doubt, lower the winch slightly, adjust the wheel position and repeat step 4.

The wheel **must** be securely retained in its correct position by the winch mechanism, or it could become loose.
6. Replace the locking cap over the wheel hoist nut. As the underside of the cap is exposed to the same conditions as the underside of the vehicle, ensure that it is firmly in place.

Note: If for any reason, the spare wheel is not to be fitted back in its hoist, the wheel hoist should be rewound as follows.

Position the lifting lug level on the cable, and wind up the hoist mechanism until it reaches its uppermost position. This is indicated by a clear physical jerk from the wheel nut brace and an audible noise.