

FOLDING AND RAISING THE REAR SEATS

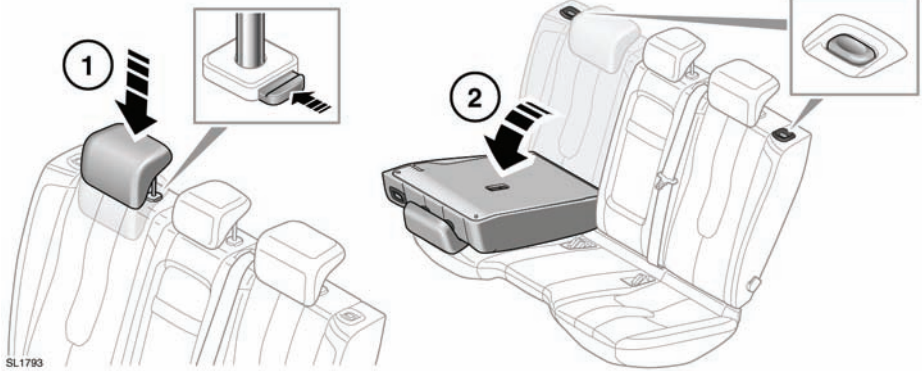

The split fold rear seat of 5 door models can be folded completely, or partially at 60/40 split, to accommodate loads and still retain seating for passengers.

To fold part or all of the seat:

1. Fully lower the head restraints.
2. Press either seat backrest release button, then fold the appropriate backrest fully forward.

Raising a folded seat is a reversal of the folding process.

When the seat back is fully raised and locked into position, the release/locking button will pop up.

With the Coupe 3 door models, if a fold is required, the smaller part must be folded first. The larger part can then be folded.

Raising the Coupe folded seats is a reversal of the folding process. Ensure that the release/locking button relocates into the correct position.



Ensure that when the backrest is raised the locking mechanism is fully engaged. If the backrests are not fully locked in place, red markers will be visible around the backrest buttons.

REAR SEAT HEAD RESTRAINTS



Adjust the head restraint so that the top of the head restraint is above the centre line of the head. An incorrectly adjusted head restraint increases the risk of death or serious injury in the event of a collision.



Do not drive or carry passengers with the head restraint removed from an occupied seat. The absence of a correctly adjusted head restraint increases the risk of neck injury in the event of a collision.



Always store a removed restraint securely.

Rear seats

Head restraints may be removed, if required (e.g. to fit larger child seats). Raise the head restraint to its uppermost position and press the locking collar. Lift the restraint out of the seatback.

To refit a head restraint, ensure it is facing the correct direction, insert the stems of the head restraint into the sockets and push it downwards until at least the first click.

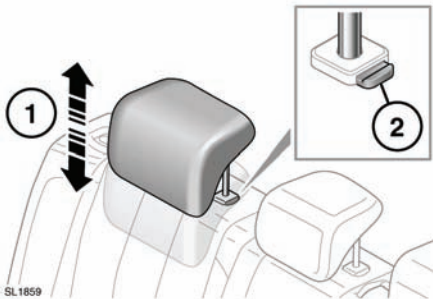

1. To raise, pull the restraint upwards.
2. To lower, press the locking collar and push down on the restraint.