

LOCKING AND ARMING THE ALARM.

- ⚠ CAUTION: No modifications or additions should be made to the anti-theft system. Such changes could cause the system to malfunction.

There are two levels of security:

- Single locking. With all doors and tailgate closed, press the lock button on the Smart Key once, to Single lock the vehicle and activate the perimeter alarm. The alarm LED in the instrument panel will start to flash and the hazard warning lamps will flash once to confirm locking. Power fold mirrors will fold in (if enabled).
- Double locking. A second press within three seconds will Double lock the vehicle and activate the full alarm system. The hazard warning lamps will flash a second time to confirm the enhanced Double lock state. An audible confirmation may also be given. The audible warning can be set/disabled via Audible Lock Warning in the Vehicle Settings menu. See **56, VEHICLE INFORMATION AND SETTINGS MENU.**

- ⚠ The vehicle will not lock if a door, the tailgate or the bonnet aperture is open, or the ignition is ON. No lamps will flash and if the lock request is via the Smart Key, there will be an audible mislock warning.

- ⚠ Ensure that the Smart Key does not remain in the vehicle prior to closure. If the vehicle is in an area of localised RF interference or the Smart Key is shielded by metal objects, the vehicle may close and lock with no means of opening again.

- ⚠ Remove any additional Smart Keys from the vehicle before locking.

Note: The fuel filler flap can be opened only when the alarm is disarmed.

LOCK CONFIRMATION

If you are uncertain whether the vehicle is locked and armed (either by single or double locking), press either the Smart Key lock button or, if Keyless entry is fitted, touch an exterior door handle lock sensor. The hazard warning lamps will flash once to indicate and confirm the current lock status.

Note: If the vehicle is **not** already locked and armed, pressing the lock button will single lock the vehicle. Press again to double lock, if required.

SINGLE LOCKING

Single locking secures the vehicle and prevents the doors from being opened from outside. The doors may still be unlocked and opened using the interior door locks and release levers. In this state, only the perimeter (exterior) alarm is activated. When the vehicle is Single locked and the alarm is armed, the alarm will sound if:

- The bonnet, tailgate or a door is opened.

In some markets where a battery backed sounder is fitted the following actions will also sound the alarm:

- The vehicle battery is disconnected.
- An attempt is made to disconnect the alarm siren.

Note: Single locking should be used in circumstances such as travelling on a ferry, if pets are to be left in the vehicle, or if a window must be left open.

DOUBLE LOCKING



Never double lock the vehicle with people, children, or pets inside. In the event of an emergency they would be unable to escape and the emergency services would be unable to release them quickly.

Double locking secures the vehicle and prevents the doors being opened from inside or outside of the vehicle. The doors cannot be unlocked or opened from inside the vehicle when double locked.

This provides additional security if the vehicle is left unattended. The vehicle cannot be opened by breaking a window and operating the interior door locks and release levers.

Additionally, double locking also activates the full alarm system with intrusion sensing (market dependent) and tilt sensing. When the vehicle is Double locked the alarm will sound if:

- The bonnet, tailgate or a door is opened.
- Movement is detected within the vehicle interior.
- A window, front or rear screen or panoramic sunroof glass is broken.
- The vehicle is raised or tilted.

In some markets where a battery backed sounder is fitted the following actions will also sound the alarm:

- The vehicle battery is disconnected.
- An attempt is made to disconnect the alarm siren.

Note: *In this state, an open window may cause the alarm to sound due to the movement of air currents. For this reason, ensure all windows are fully closed before double locking the vehicle.*

MISLOCK

When locking the vehicle with the Smart Key, if one or more of the doors, the bonnet or the tailgate is not fully closed, or the ignition is ON, the vehicle will NOT lock and there will be an audible mislock error warning. The hazard warning lamps will NOT flash and the door mirrors (if enabled) will NOT fold in. Check that all doors, the bonnet and the tailgate are closed properly. Ensure the ignition is turned OFF and lock the vehicle again. If the mislock persists, consult a Land Rover Dealer/Authorised Repairer.

GLOBAL CLOSING



Ensure that no children, pets, or obstructions are in any open aperture before operating global closing.

Ensure that all doors are closed. Press and hold the Smart Key lock button for 3 seconds. The vehicle will single lock and the alarm will be armed immediately. After 3 seconds any open windows will be closed.

KEYLESS LOCKING



Never double lock the vehicle with people, children or pets inside. In the event of an emergency they would be unable to escape and the emergency services would be unable to release them quickly.



The Smart Key may not be detected if it is placed within a metal container or if it is shielded by a device with a back-lit LCD screen, such as a smart phone, laptop (including laptop bag), games console etc.

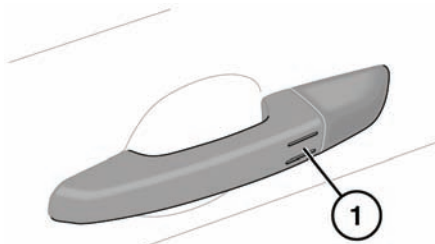

SL1858

The vehicle will not lock automatically.

Note: Keyless locking will activate only if the Smart Key is detected outside the vehicle. If no Smart Key is present, no locking will occur.

- To single lock the vehicle, touch the lock sensor **(1)** on a door handle once. The hazard warning lamps will flash once to confirm locking. Power fold mirrors will fold in (if enabled).
- To double lock the vehicle, touch **(1)** twice within 3 seconds. The hazard warning lamps will flash twice to confirm (with a long second flash). Power fold mirrors will fold in (if enabled). An audible confirmation may also be given (if enabled).

Note: When locking the vehicle via Keyless locking, if one or more of the doors, the bonnet or the tailgate is not fully closed, or the ignition is ON, the vehicle will NOT lock. There will be NO audible mislock error warning. The hazard warning lamps will NOT flash and the door mirrors (if enabled) will NOT fold in. Check that all doors, the bonnet and the tailgate are closed properly. Ensure the ignition is turned OFF and lock the vehicle again. If the mislock persists, consult a Land Rover Dealer/Authorised Repairer.

KEYLESS GLOBAL CLOSING

To initiate global window closing (if enabled), touch and hold the lock sensor **(1)** for 3 seconds. This will also single lock the vehicle and activate the alarm.

Note: The windows will close only while the sensor **(1)** is covered. To fully secure the vehicle, continue to touch the sensor until all windows are fully closed.

DRIVE-AWAY LOCKING

Drive-away locking automatically locks all doors at a set speed when the vehicle is in motion. This feature can be enabled/disabled via Drive-away locking in the Vehicle Settings menu. See **56, VEHICLE INFORMATION AND SETTINGS MENU**.

SELECTING VALET MODE

Valet mode allows the vehicle to be driven, e.g., by a parking attendant, but leaves the tailgate locked and restricts use of the touch screen. This prevents access to telephone numbers, navigation addresses and audio system settings.

From the **Home** menu, select **Valet**:

Enter a four digit Personal identification Number (PIN) (personally chosen). On completion, touch the **OK** soft key.

If you wish to cancel the PIN, select **Delete**.

After entering the PIN, you will be prompted to enter the PIN again. Enter the same PIN and touch **OK** to confirm.

A pop-up screen is displayed, confirming your vehicle is now in Valet mode.

INTERIOR PROTECTION

The interior protection feature of the full alarm system may be temporarily disabled via Alarm sensors in the Vehicle Settings menu. See **56, VEHICLE INFORMATION AND SETTINGS MENU**.

Note: If the interior protection is temporarily disabled, it will be automatically enabled the next time the vehicle is double locked with the Smart Key.

BATTERY-BACKED SOUNDER

In certain markets, a battery backed sounder is fitted. This device will sound if it or the vehicle battery is disconnected while the security system is armed.

TILT SENSOR

The tilt sensor detects any change to the vehicle's angle to the ground. When the alarm is armed and the vehicle is double locked, any change in the vehicle's angle will activate the tilt alarm.

Note: The tilt sensors can be temporarily disabled for the next time the vehicle is locked. See Alarm Sensors, **56, VEHICLE INFORMATION AND SETTINGS MENU**. The sensors will be automatically enabled the next time the vehicle is double locked with the Smart Key.

DOOR LOCK AND RELEASE LEVERS

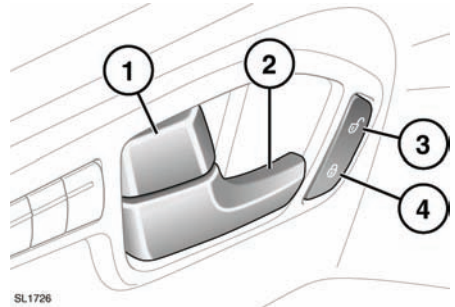

1. Press a locking lever to lock a door. Pull the lever back to unlock. Operating either front door locking levers will lock or unlock all doors.
2. Pull a release lever to open a front door. To unlock and open a rear door, first operate the lock lever, then pull the release lever.
3. Press the master unlock button to unlock all doors and tailgate.
4. With all doors closed, press the master lock button to lock all doors and tailgate.

Note: If the vehicle was locked with the Smart Key, operating an interior door release lever will unlock only that door. If the door is opened the alarm will sound.

Note: If the vehicle has been double locked, the interior door release levers will not operate. The vehicle must be unlocked using the Smart Key.