

## ENGINE OIL CHECK

### **NOTICE**

*Check the engine oil weekly. If any significant or sudden drop in oil level is noted, seek qualified assistance.*

### **NOTICE**

*If the message **OIL PRESSURE LOW** is displayed, stop the engine as soon as it is safe to do so and seek qualified assistance. Do not start the engine until the cause has been rectified.*

Prior to checking the oil level ensure that:

- The vehicle is on level ground.
- The engine oil has reached working temperature (oil is hot).
- The engine has been switched off for 15 minutes, as the system will not give an accurate reading until the oil level has stabilised.

The oil level can then be checked as follows:

1. Switch on the ignition (do not start the engine).
2. Ensure Park (**P**) is selected.
3. Select the **Service** menu using the driver information menu control.
4. Select **Oil level display** from the Service menu. The current oil level status and topping-up advice is displayed in the instrument panel.
5. Top-up as instructed

Messages to the right of the gauge advise of any action you may need to take.

If the oil level is within the required operating range, the message **Engine Oil Level OK** will be displayed. Do not add any additional oil to the engine.

If the oil level is below the required operating range, a message advising you how much oil to add will be displayed (e.g. **Add 0.5 Litre**). Add the recommended quantity of oil.

If the message **Engine Oil Level Overfilled** is displayed, seek qualified assistance immediately. Do not drive the vehicle as this will cause serious damage to the engine.

If the message **Engine Oil Level Underfilled** is displayed, add 3.5 pints (2 litres) of oil, then recheck the level.

If the message **Engine Oil Level Not Available** is displayed, the oil level is stabilising. Switch off the ignition, wait 10 minutes, then recheck the oil level display.

If the warning message **ENGINE OIL LEVEL MONITOR SYSTEM FAULT** is displayed, seek qualified assistance.

## TOPPING UP THE ENGINE OIL

### **NOTICE**

*Your vehicle warranty may be invalidated if damage is caused by using oil that does not meet the required specification.*

### **NOTICE**

*Failure to use an oil that meets the required specification could cause excessive engine wear, a build up of sludge and deposits, and increase pollution. It could also lead to engine failure.*

### **NOTICE**

*Overfilling with oil could result in severe engine damage. Oil should be added in small quantities and the level re-checked to ensure that the engine is not overfilled.*

1. Remove the oil filler cap.
2. Add oil as instructed by the oil level display.
3. Clean up any oil spilled during topping-up.

4. Check the oil level again after 10 minutes. It is essential to use the correct specification oil and to ensure it is suitable for the climatic conditions in which the vehicle is to be operated.

**Note:** The approximate quantity of oil required to raise the level from **MIN** to **MAX** on the dipstick is 3.5 pints (2 litres) for all models.

## ENGINE OIL SPECIFICATION

Use only 5W-20 oil meeting specification WSS-M2C925-A.

In an emergency, if the oil specification above is unavailable, top up with a maximum of 2 pints (1 litre) of oil meeting specification ILSACGF-4 API SM.



Land Rover recommends Castrol oils.

## COOLANT LEVEL CHECK

### NOTICE

*Running the engine without coolant will cause serious engine damage.*

The coolant level in the expansion tank should be checked at least weekly (more frequently in high mileage or arduous operating conditions). Always check the level when the system is cold.

Ensure the coolant level remains between the COLD FILL RANGE indicator marks located on the side of the expansion tank. Ignore any coolant visible in the top section of the tank

If coolant/steam is expelled from the pressure cap, or the level has dropped suddenly, or by a large amount, arrange for the vehicle to be examined by a qualified technician as soon as possible.

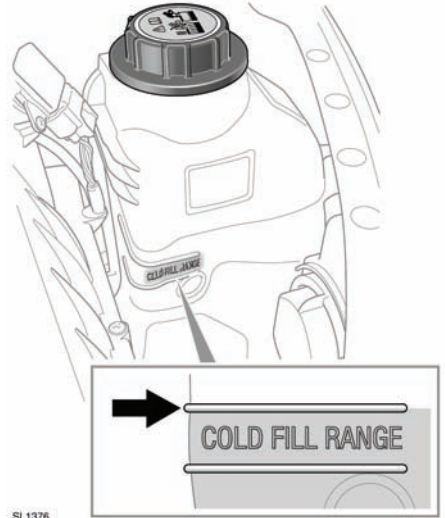

SL1376

## TOPPING UP THE COOLANT

### ⚠ WARNING

Never remove the filler cap when the engine is hot - escaping steam or scalding water could cause serious personal injury.

Unscrew the filler cap slowly, allowing the pressure to escape before removing completely.

### ⚠ WARNING

Avoid spilling antifreeze onto a hot engine - a fire may result.

## **NOTICE**

*When travelling in territories where the water supply contains salt, always ensure you carry a supply of fresh (rain or distilled) water.*

*Topping up with salt water will cause serious engine damage.*

Top-up to the upper level indicator mark of the COLD FILL RANGE located on the side of the expansion tank. Use only a 50% mix of water and Castrol SF antifreeze.

**Note:** *In an emergency - and only if the approved antifreeze is unavailable - top-up the cooling system with clean water, but be aware of the resultant reduction in frost protection. Do not top-up or refill with conventional antifreeze formulations. If in doubt consult a qualified technician.*

Ensure the cap is tightened fully after top-up is completed by turning the cap until the ratchet cap clicks.

## **ANTIFREEZE**

### **⚠ WARNING**

Antifreeze is poisonous and can be fatal if swallowed - keep containers sealed and out of the reach of children. If accidental consumption is suspected, seek medical attention immediately.

### **⚠ WARNING**

If the fluid comes into contact with the skin or eyes, rinse immediately with plenty of water.

## **NOTICE**

*The use of non-approved antifreeze will have an adverse effect on the engine cooling system and therefore engine durability.*

## **NOTICE**

*Antifreeze will damage painted surfaces; soak up any spillage with an absorbent cloth immediately and wash the area with a mixture of car shampoo and water.*

Antifreeze contains important corrosion inhibitors. The antifreeze content of the coolant must be maintained at 50% ± 5% all year round (not just in cold conditions). To ensure that the anti-corrosion properties of the coolant are retained, the antifreeze content should be checked once a year and completely renewed every ten years, regardless of distance travelled. Failure to do so may cause corrosion of the radiator and engine components.

The specific gravity of a 50% antifreeze solution at 68°F (20°C) is 1.068 and protects against frost down to -40°F (-40°C).

## **BRAKE FLUID CHECK**

### **⚠ WARNING**

Seek qualified assistance immediately if brake pedal travel is unusually long or if there is any significant loss of brake fluid. Driving under such conditions could result in extended stopping distances or complete brake failure.

### **⚠ WARNING**

Brake fluid is highly toxic - keep containers sealed and out of the reach of children. If accidental consumption of fluid is suspected, seek medical attention immediately.

### **⚠ WARNING**

If the fluid comes into contact with the skin or eyes, rinse immediately with plenty of water.

### **⚠ WARNING**

Take care not to spill brake fluid onto a hot engine - a fire may result.

## **⚠ WARNING**

Do not drive the vehicle with the fluid level below the MIN mark.

**BRAKE**

USA



Canada and Mexico

If the quantity of fluid in the brake reservoir drops below the recommended level, a red warning lamp in the instrument pack will illuminate.

**Note:** If the warning lamp illuminates while the vehicle is being driven, stop the vehicle as soon as safety permits by gently applying the brakes. Check and top-up the fluid level if necessary.

With the vehicle on level ground, check the fluid level at least every week (more frequently in high mileage or arduous operating conditions).

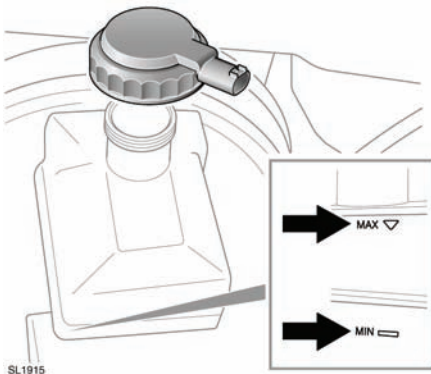

Look at the fluid level through the side of the transparent reservoir without removing the filler cap.

The brake fluid must be between the **MAX** and **MIN** marks.

## TOPPING UP THE BRAKE FLUID

### **NOTICE**

Brake fluid will damage painted surfaces. Soak up any spillage with an absorbent cloth immediately and wash the area with a mixture of car shampoo and water.

### **NOTICE**

Only use new fluid from an airtight container. Fluid from opened containers or fluid previously bled from the system will have absorbed moisture, which will adversely affect performance and must not be used.

1. Clean the filler cap before removing to prevent dirt from entering the reservoir.
2. Remove the filler cap.
3. Top-up the reservoir to at least the minimum mark using Shell DOT4 ESL brake fluid. If Shell DOT4 ESL is not available, a low viscosity DOT4 brake fluid that meets ISO 4925 class 6 and Land Rover LRES22BF03 requirements may be used.

### **NOTICE**

Do not top-up the brake fluid to the maximum mark unless the brake pads have been replaced. If unsure seek qualified assistance.

4. Replace the cap and reservoir cover.

## POWER STEERING FLUID CHECK

### **⚠ WARNING**

Power steering fluid is highly toxic. Keep containers sealed and out of reach of children. If accidental consumption of fluid is suspected, seek medical attention immediately.

# Fluid level checks

## **⚠ WARNING**

If the fluid comes into contact with the skin or eyes, rinse immediately with plenty of water.

## **⚠ WARNING**

Take care not to spill power steering fluid onto a hot engine - a fire may result.

## **NOTICE**

Do not start the engine if the fluid level has dropped below the **MIN** mark. Severe damage to the steering pump could result.

## **NOTICE**

Seek qualified assistance immediately if there is a noticeable drop in the fluid level. Severe damage to the steering pump could result.

## **NOTICE**

If fluid loss is slow, the reservoir may be topped-up to the upper level mark to enable the vehicle to be driven to a repair facility for examination. However, it is recommended that you seek qualified assistance before driving.

Check and top-up the fluid with the vehicle on level ground, engine switched off, and the system cold. Ensure that the steering wheel is not turned after stopping the engine.

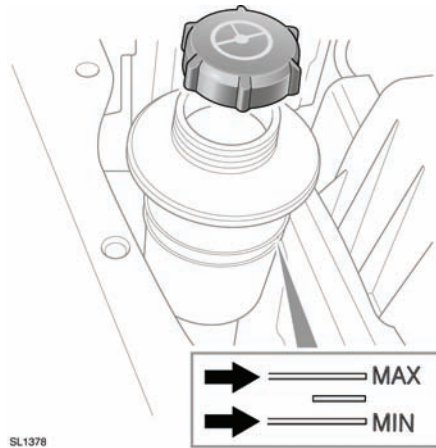

The level of fluid can be seen through the translucent body of the reservoir.

The fluid level should be between the **MIN** and the **MAX** marks.

## **TOPPING UP THE STEERING FLUID**

## **⚠ WARNING**

Do not spill power steering fluid onto a hot engine. Doing so may result in a fire.

## **NOTICE**

Power steering fluid will damage painted surfaces. Soak up any spillage with an absorbent cloth immediately and wash the area with a mixture of car shampoo and water.

## **NOTICE**

Do not fill the reservoir above the **MAX** mark.

1. Clean the filler cap before removing to prevent dirt from entering the reservoir.
2. Remove filler cap.
3. Using Texaco Cold Climate PSF fluid 14315, top up the reservoir until the fluid level is between the **MIN** and **MAX** marks.

4. Replace filler cap.

## WASHER FLUID CHECK

### ⚠ WARNING

Some screen washer products are inflammable, particularly if high or undiluted concentrations are exposed to sparking. Do not allow washer fluid to come into contact with naked flames or sources of ignition.

### ⚠ WARNING

If the vehicle is operated in temperatures below 40°F (4°C), use a washer fluid with antifreeze protection. In cold weather, failure to use a washer fluid with frost protection, could result in impaired vision and increase the risk of a vehicle crash.

### NOTICE

Do not use an antifreeze or vinegar/water solution in the washer reservoir - antifreeze will damage painted surfaces, while vinegar can damage the windshield washer pump.

### NOTICE

Body panels may suffer discoloration as a result of windshield washer fluid spillage. Take care to avoid spillage, particularly if an undiluted or high concentration is being used. If spillage occurs, wash the affected area immediately with water.

**Note:** National or local regulations restrict the use of Volatile Organic Compounds (VDCs) which are commonly used as antifreeze agents in washer fluid. A washer fluid with limited VDC content should be used only if it provides adequate freeze resistance for all climates in which the vehicle will be operated.

## TOPPING UP THE WASHER FLUID

The washer reservoir supplies both front and rear screen washer jets and headlamp washer jets.

Check and top-up the reservoir level at least every week. Always top-up with screen washer fluid to prevent freezing.

Operate the washer switches periodically to check that the nozzles are clear and properly directed.

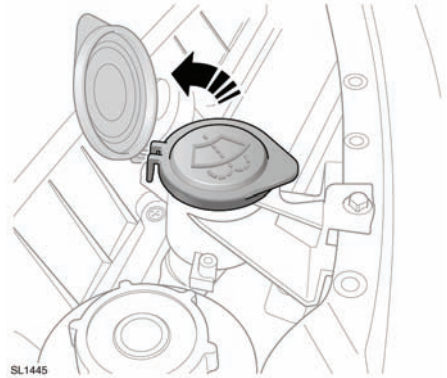

1. Clean the filler cap before removing to prevent dirt from entering the reservoir.
2. Remove filler cap.
3. Top-up the reservoir until the fluid is visible in the filler neck.
4. Replace filler cap.