

## USING SEATBELTS AND CHILD SAFETY LOCKS

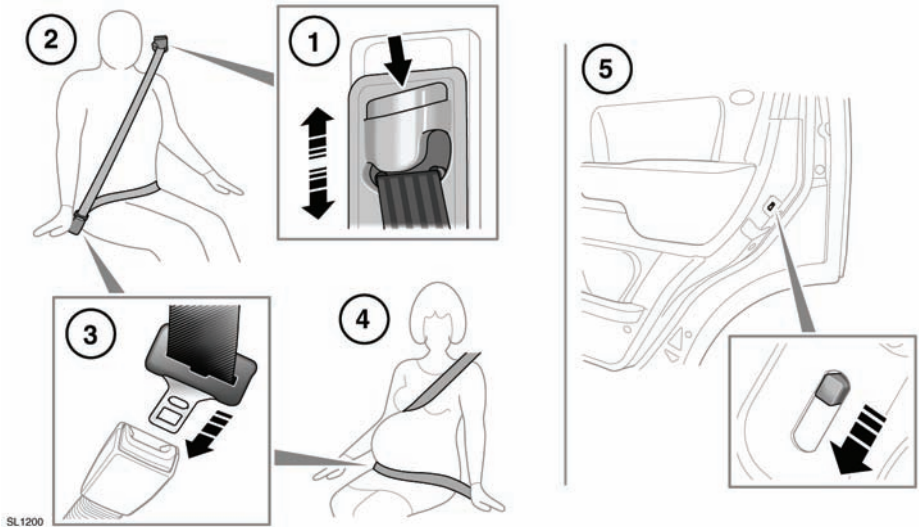

### 1. SEAT BELT HEIGHT ADJUSTMENT:

Press to release the catch.

With the catch depressed move the mechanism slide up or down to the required height. Ensure that the locking mechanism has engaged.

When correctly positioned the seat belt should cross the collar bone at the mid-point between the neck and end of your shoulder.

Where possible, rear seat passengers should adjust their seating position to achieve the same seat belt position.

### **⚠️ WARNING**

Ensure that the height is correctly adjusted and the mechanism is locked in place before driving. Do not attempt to adjust the seat belt height once the vehicle is in motion. Doing so may cause you to lose control of the vehicle, or incorrectly adjust the seat belt.

### **⚠️ WARNING**

Do not use comfort clips or other devices that create slack in the seat belt system.

## **⚠️WARNING**

No modifications or additions should be made by the user which will either prevent the seat belt adjusting devices from operating to remove slack, or prevent the seat belt assembly from being adjusted to remove slack. A slack seat belt offers a greatly reduced level of occupant protection in an impact.

### **2. PUTTING ON A SEAT BELT:**

Draw the belt out smoothly, ensure that the belt height, the seat and your position on the seat, are correct.

## **⚠️WARNING**

Seat belts are designed to bear upon the bony structure of the body and should be worn across your chest and shoulders and low across the pelvis. Never wear the seat belt as just a lap belt.

## **⚠️WARNING**

Seat belts should be adjusted as firmly as possible, consistent with comfort, to provide the protection for which they have been designed. A slack belt will greatly reduce the protection afforded to the wearer.

## **⚠️WARNING**

Belts should not be worn with the straps twisted.

## **⚠️WARNING**

Each belt assembly must only be used by one occupant. Never let children share a seat or seat belt.

## **⚠️WARNING**

Riding with a reclined seatback increases your chance of serious or fatal injuries in the event of a collision or sudden stop. The protection of your restraint system (seat belts and airbags) is greatly reduced by reclining your seat. Seat belts must be snug against your hips and chest to work properly. The more the seatback is reclined, the greater the chance that an occupant's hips will slide under the lap belt or the occupant's neck will strike the shoulder belt. Drivers and passengers should always sit well back in their seats, properly belted, and with the seatbacks upright.

## **⚠️WARNING**

Never place anything between you and the seat belt. It can be dangerous and reduce the effectiveness of the seat belt in preventing injury.

## **⚠️WARNING**

The air bag supplementary restraint system (SRS) is designed to add to the overall effectiveness of the seat belts. It does not replace them. Seat belts must always be worn.

## **⚠️WARNING**

Do not carry hard, fragile, or sharp items between your person and the seat belt. In an impact, the pressure on such items can cause them to break, which in turn may cause death or serious injury.

## **⚠️WARNING**

Seat belts should be worn by all vehicle occupants, for every journey, no matter how short. Failure to do so will greatly increase the risk of death or serious injury in the event of an accident.

## **⚠️ WARNING**

**Never wear just the lap belt or just the shoulder belt of a lap/shoulder diagonal seat belt. Both of these actions are extremely dangerous and may increase your risk of injury.**

### **3. FASTENING A SEAT BELT:**

With the seat belt correctly positioned, place the metal tongue into the buckle nearest to you. Press it in until a click is heard.

To release the seat belt, press the red button.

*Note: When releasing the seat belt it is advisable to hold the belt before pressing the release button. This will prevent the belt from retracting too quickly.*

### **4. SEAT BELT USE DURING PREGNANCY:**

Position the lap strap comfortably across the hips beneath the abdomen. Place the diagonal part of the seat belt between the breasts and to the side of the abdomen, as illustrated.

## **⚠️ WARNING**

**Position the seat belt correctly for the safety of the mother and unborn child. Never wear just the lap strap, and never sit on the lap strap while using just the shoulder strap. Both of these actions are extremely dangerous, and may increase your risk of serious injury in the event of an accident or during emergency braking.**

## **⚠️ WARNING**

**Never place anything between you and the seat belt in an attempt to cushion the impact in the event of an accident. It can be dangerous and will reduce the effectiveness of the seat belt in preventing injury.**

## **⚠️ WARNING**

**Ensure that the seat belt is not slack or twisted.**

### **5. CHILD SAFETY LOCKS:**

There is a locking lever on each of the rear doors. When the lever is in the down position the closed door is locked and cannot be opened from inside the vehicle.

## **SEAT BELT CARE**

### **⚠️ WARNING**

**The belt should be replaced if webbing becomes frayed, contaminated or damaged. It is essential to replace the entire assembly after it has been worn in a severe impact even if damage to the assembly is not obvious.**

**If any damage, wear, cuts, defects, or impaired operation are noted with the seat belts, the vehicle should be taken to a Land Rover Retailer/Authorized Repairer for immediate attention. Do not use the vehicle if the seat belts cannot be operated correctly.**

**Care must be taken to avoid contamination of the webbing with polishes, oils and chemicals, and particularly battery acid. Cleaning may safely be carried out using mild soap and water. Contaminated seat belts may not operate correctly in an impact and cannot be relied upon.**

**When using seat belts to restrain items other than occupants, take care to ensure that the belts are not damaged, or exposed to sharp edges.**

## SEAT BELT CHECKS

**Note:** If the vehicle is parked on an incline, the seat belt mechanism may lock. This is not a fault and the belt should be gently eased out from the upper anchorage.

The seat belts should be inspected regularly to check for fraying, cuts, wear to the webbing and the condition and security of the mechanism, buckles, adjusters and mounting points.

- With the seat belt fastened, give the webbing near the buckle a quick upward pull. The buckle must remain securely locked.
- With the seat belt unfastened, unreel the seat belt to the limit of its travel. Check that it unreels smoothly with no snatches or snags. Allow the belt to fully retract, again checking for smooth operation.
- Partially unreel the seat belt, then hold the tongue plate and give a quick forward pull. The mechanism must lock and prevent any further unreeling.

## WARNING

**If any of the seat belts fail to meet those criteria, immediately contact your Land Rover Retailer/Authorized Repairer.**

## SEAT BELT REMINDER



If the driver's seat belt is not fastened when the vehicle is in motion, a chime will be heard and the seat belt warning indicator will illuminate. The warning chime and indicator will also be activated if the front passenger seat is occupied without the seat belt being fastened.

**Note:** Objects on the front passenger seat may activate the seat belt reminder. It is recommended that any objects placed on the front passenger seat are secured using the seat belt.

## CHILD SAFETY LOCKS

If children are to be carried in the rear seat positions, it is recommended that the rear door interior handles are disabled.

See **USING SEATBELTS AND CHILD SAFETY LOCKS** (page 25).

## CHILD SEATS

### WARNING

According to crash statistics, children are safer when properly restrained in the rear seats than in the front seat. The air bags alone will not prevent children from being seriously injured or killed. Never place a child in any type of child restraint or booster seat in the front passenger seat. Children under the age of 13 should always ride in the rear.

Make sure the child seat fits your child properly. Always check the seat manufacturer's instructions and labels for height and weight limits. For more specific guidance, consult your pediatrician.

There are three general types of child restraint systems: rear-facing infant seats, forward-facing toddler seats, and belt-positioning booster seats:

Rear-facing seats are used in the back seat from birth to at least 1 year of age and at least 20 lbs (9 kg).

Forward-facing toddler seats are used after outgrowing an infant seat until about age 4 and 40 lbs (18 kg).

Boosters seats are used in the back seat after outgrowing the toddler seat until vehicle seat belts fit properly without the booster. Usually at age 8 or at least 4 ft 9 in (145 cm).

### DANGER

Do not allow a baby or infant to be held or carried on the lap. The force of a crash can increase effective body weight by as much as thirty times, making it impossible to hold onto the child. At all times, children should be restrained in age and size appropriate child seats to reduce the risk of death or serious injury in a crash.

### WARNING

**Children could be endangered in a crash if their child restraints are not properly secured in the vehicle. Always follow the instructions that accompany the child seat carefully.**

Child restraint systems are designed to be secured in vehicle seats by use of the lap belts or the lap belt portion of a lap-shoulder belt. Children could be endangered in a crash if their child restraints are not properly secured.

The seat belts fitted to your vehicle are designed for adults and larger children. For their safety it is very important for all infants and children of 12 years and under to be restrained in a suitable child safety seat appropriate to their age and size.

If it is essential that a child travels in the front passenger seat (and national legislation permits this), Land Rover recommends that the following preparations are made before fitting the child restraint.

- Adjust the front passenger seat fully rearwards.
- Adjust the lumbar support to its minimum support position.
- Adjust the seat cushion to its highest position. If cushion rake adjustment is possible, adjust it to its lowest position.
- Adjust the seat back to the fully upright position.
- Adjust the seat belt adjustable upper anchorage to its lowest position.

### WARNING

**Extreme hazard! Never place a rearward facing child restraint on the front passenger seat. The infant could be seriously injured or killed if the air bag deploys.**



SL1545

This symbol, affixed to the end of the fascia on the passenger side, warns against the use of a rear-facing child seat in the front passenger seat, when a front passenger air bag is fitted and operational.

## SEAT BELT LOCKING MECHANISM

The rear outer seat belts and front passenger seat belts have a locking mechanism which improves the retention of child seats.

The procedure to install a child seat is as follows:

1. Place the child seat in the vehicle, attach the seat belt and secure the buckle in accordance with the manufacturer's fitting instructions.
2. Pull on the shoulder section of the belt to unreel all of the remaining webbing to the limit of its travel. This will engage the automatic locking feature which then acts as a ratchet, only allowing the webbing to retract.
3. Allow the seat belt to retract onto the child seat (a clicking sound will confirm that the ratchet has engaged), while firmly pushing the child seat into the vehicle seat.
4. Ensure that there is no slack in the seat belt, by pulling upwards on the shoulder belt immediately above the child restraint.

When the child seat is removed and all of the seat belt webbing is allowed to retract, the seat belt locking mechanism reverts to normal operation.

## BOOSTER SEATS

In a situation where a child is too large to fit into a child safety seat but is still too small to safely use just the three point belt, a booster seat is recommended for maximum safety. Follow the manufacturer's instructions for fitting and use, then adjust the seat belt to suit.

## CHILD RESTRAINT CHECK LIST

Every time a child travels in the vehicle observe the following:-

### Non-LATCH child restraints

- Carefully follow the instructions provided by the manufacturer of the restraint system.
- Always use the appropriate child restraints and adjust harnesses for every child, every trip.
- Avoid dressing a child in bulky clothing and do not place any objects between the child and the restraint system.
- Regularly check the fit of a child seat and replace seats or harnesses that show signs of wear.
- Ensure that you have removed all slack from the adult seat belt.
- No child seat is completely child-proof. Encourage a child not to play with the buckle or harness.
- Never leave a child unsupervised in the vehicle.
- Activate the rear door child safety locks. See **USING SEATBELTS AND CHILD SAFETY LOCKS** (page 25). item 5.

- Set a good example - always wear your seat belt.

## **LATCH child restraints**

- Always attach the top tether when installing the LATCH seat.
- Carefully follow the instructions supplied with the child seat. Always give the LATCH seat a final pull, to ensure that the lower anchors are secure.
- Always use the appropriate child restraints and adjust the harnesses for every child, every trip.
- Make sure that a child falls into the correct weight range for the seat. Avoid dressing a child in bulky clothing and do not place any objects between the child and the restraint system.
- Regularly check the fit of a child seat and replace seats and harnesses that show signs of wear.
- No child seat is completely child-proof. Encourage children not to play with the buckle or harness.
- Never leave a child unsupervised in the vehicle.
- Activate the rear door child safety locks. See **USING SEATBELTS AND CHILD SAFETY LOCKS** (page 25), item 5.
- Set a good example - always wear your seat belt.

## **WARNING**

**Child restraint anchorages are designed to withstand only those loads imposed by correctly fitted child restraints. Under no circumstances are they to be used for adult seat belts, harnesses or for attaching other items or equipment to the vehicle.**

## CHILD SEAT POSITIONING

<b>PROPER CHILD SAFETY SEAT USE CHART</b> <b>Buckle Everyone. Children Age 12 and Under in Back.</b>			
	<b>INFANTS</b>	<b>TODDLER</b>	<b>YOUNG CHILDREN</b>
<b>WEIGHT</b>	Birth to at least 1 year old and at least 20 lb. (9kg).	Over 1 year and over 20 lb. (9kg) to about 4 years and 40 lb. (18kg) or child reaches highest weight or height allowed by child seat manufacturer.	Children who have outgrown their forward-facing toddler seat until vehicle seat belts fit properly, usually when a child is at least 4 ft 9 in. tall and 8 years old.
<b>TYPE of SEAT</b>	Rear-facing infant seat or convertible seat.	Convertible seat or Forward-facing toddler seat.	Belt-positioning booster seat.
<b>SEAT POSITION</b>	Rear-facing only.	Forward-facing.	Forward-facing.
<b>ALWAYS MAKE SURE</b>	Harness straps should be at or below shoulder level.	Harness straps should be at or above shoulder level.	Use booster seat with vehicle's lap and shoulder belt. Keep lap portion low and tight across the pelvis and upper thigh area to avoid abdominal injuries. Keep shoulder portion snug crossing the chest and shoulder. Never across the neck or face and never let a child place the shoulder belt behind their back.
<b>CHILDREN RIDE IN REAR</b>	Even with advanced air bags, children can be seriously injured or killed. Never place a child in any type of child restraint or booster seat in the front passenger seat. Children under the age of 13 should always ride in the back seat.		

When installing a child seat in the rear, the front seat must be moved forward and upwards to install any rear-facing child seat.

Care must be taken not to load any part of the child seat when repositioning the front seat. The space available for front seat occupants will be reduced by the fitment of any rearward-facing child seat.

## **⚠ WARNING**

**Crash statistics show that children are safest when properly restrained in a child restraint system appropriate for their age and weight and secured in a rear seating position.**

## **LATCH CHILD RESTRAINT ANCHOR POINTS**

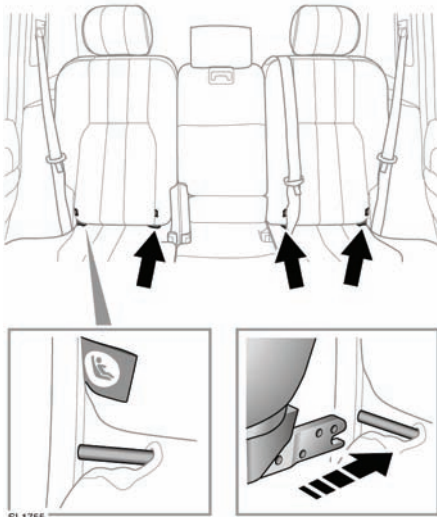

LATCH anchorage child restraints can be fitted only to the outer seat positions on the second row of seats.



This symbol is shown on a label sewn into the seats to indicate the position of the LATCH lower anchorages.

To install a LATCH anchorage child seat:-

1. Locate the LATCH locking mechanism.
2. For child seats fitted with **rigid** lower LATCH connectors, slide the child seat locking mechanism into the protective sleeves and onto the anchor bars.

For child seats fitted with **non-rigid** LATCH connectors, connect the lower tether strap hooks to the anchor bars and tighten the straps.

3. If an upper tether is fitted to the child seat, ensure it is properly secured to the upper tether anchorages on the rear of the seats.

Test the security of the child restraint. To do this, attempt to pull the restraint away from the vehicle seat and twist the restraint from side to side. Even if the restraint appears secure, you should still check the anchor points visually, to ensure correct attachment.

## **⚠ WARNING**

**Do not attempt to fit a LATCH child restraint to the center rear seating position. The anchor bars are not designed to hold a LATCH child restraint in this position. Install only using seat belts (non-LATCH system) and the top tether at this position.**

## **⚠ WARNING**

**If the restraint is not correctly anchored, there is a significant risk of injury to the child in the event of a collision or emergency braking.**

## **⚠ WARNING**

**If removing a head restraint in order to fit a child restraint, always secure the head restraint when storing it.**

## ATTACHING TETHER STRAPS

### **⚠WARNING**

Child restraint anchorages are designed to withstand only those loads imposed by correctly fitted child restraints. Under no circumstances are they to be used for adult seat belts, harnesses or for attaching other items or equipment to the vehicle.

### **⚠WARNING**

Always follow the child seat or restraint system manufacturer's instructions when fitting tether straps.

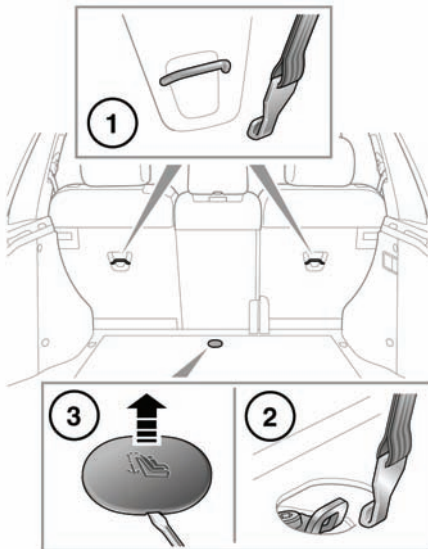

SL1201

1. Your vehicle is equipped with tether strap anchorage points behind the second row seat frames. These should be used to attach straps from child seats or restraint systems.

2. A floor mounted tether anchorage is provided for the center seat position. Do not use this anchor position with a LATCH anchorage child seat.
3. Use a small, flat bladed screwdriver to remove the circular cover.

### **⚠WARNING**

If a child seat or restraint system is to be fitted to the center seating position, the center armrest must be in the stowed position (folded into the seat).

### **⚠WARNING**

When fitting a child seat or restraint system, always pass the tether strap over the top of the seat back and beneath the head restraint.

- A. Install the child restraint securely in one of the rear seating positions.
- B. Pass the tether strap over the seat back and beneath the head restraint.
- C. Attach the tether strap hook to the tether anchor point on the back of the seat. Ensure that the tether strap hook is facing the towards the back of the seat (see illustration).
- D. Tighten the tether strap according to the child restraint manufacturer's instructions.

## AIR BAG SUPPLEMENTARY RESTRAINT SYSTEM (SRS)

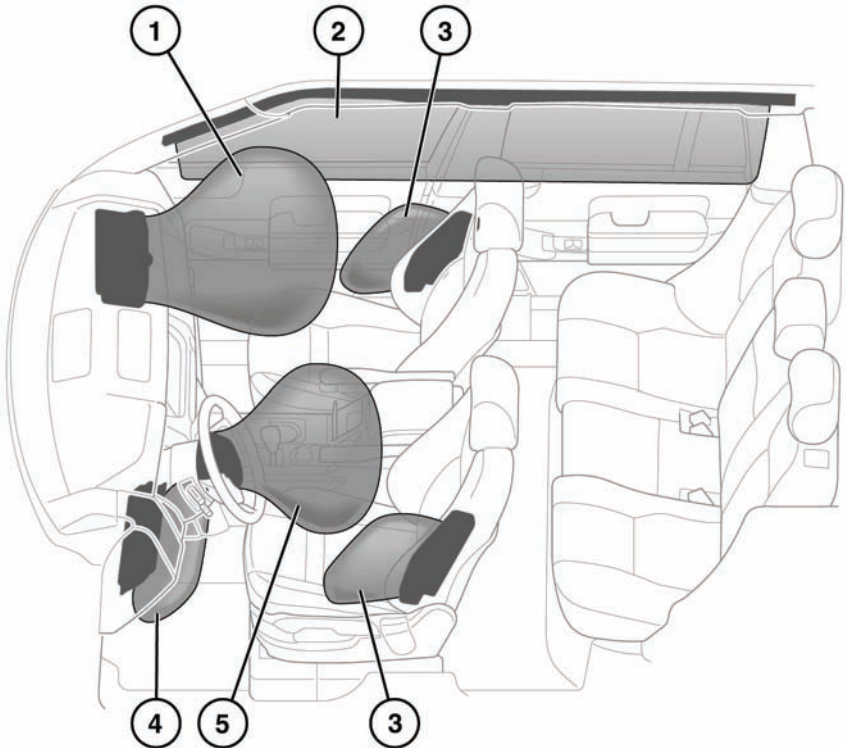

SL1202

1. Passenger air bag.
2. Curtain air bag.
3. Side air bags.
4. Knee-bolster air bag.
5. Driver air bag.

**Note:** The general location of air bags fitted to the vehicle are marked by the word AIR BAG.

### **⚠ DANGER**

High speed impacts may cause serious injury or death irrespective of safety features fitted to the vehicle. Always drive with caution and consideration for the vehicle's characteristics, road and weather conditions, and do not exceed any speed limits in force.

## **⚠ DANGER**

Seat belts should be worn at all times, by the driver and passengers in all seating positions. The air bag supplementary restraint system (SRS) cannot provide protection in some types of impact. Under these circumstances, the only protection will be provided by a correctly worn seat belt.

## **AIR BAG OPERATION**

### **⚠ WARNING**

National Highway Traffic Safety Administration (NHTSA) recommends a minimum distance of 10 inches (25 cm) between an occupant's chest and the driver's air bag module.

### **⚠ WARNING**

For the air bags to operate correctly the roof lining and door post trims must be in good condition, correctly fitted, and free from obstruction. Any damage, wear, or incorrect fitment should be referred to your Land Rover Retailer/Authorized Repairer as soon as possible for examination and repair.

### **⚠ WARNING**

Air bags inflate at high speeds. To minimise the risk of injury, ensure that all vehicle occupants wear correctly positioned seat belts, sit correctly in the seats, and position the seats as far back as practical.

### **⚠ WARNING**

Air bag inflation takes place instantaneously, and cannot protect against the effects of secondary impacts. Under these circumstances the only protection will be provided by a correctly worn seat belt.

## **⚠ WARNING**

Phone systems should be installed only by qualified persons familiar with the operation of, and requirements for, vehicles fitted with SRS. If you are in any doubt, seek advice from your Land Rover Retailer/Authorized Repairer.

Air bag deployment is dependent on the rate at which the passenger compartment changes velocity following the collision. Circumstances affecting different collisions (vehicle speed, angle of impact, type and size of object hit, etc.), vary considerably and will affect the rate of deceleration accordingly.

The Supplementary Restraint System components include:-

- SRS warning indicator.
- Rotary coupler.
- Air bag modules.
- Seat belt pre-tensioners.
- Air bag diagnostic control unit.
- Crash sensors.
- Air bag wiring harness.
- Seat occupancy sensor.
- Front passenger belt tension sensor.

The air bags and SRS are not designed to operate as a result of:

- Rear impacts.
- Minor front impacts.
- Minor side impacts.
- Heavy braking.
- Driving over bumps and pot holes.

Therefore, it follows that considerable superficial damage to the vehicle can occur, without causing the air bags to deploy.

**Note:** If as a result of an impact, you believe the air bags should have deployed and they failed to do so, please call 1 (800) 637-6837 for advice, or arrange for a Land Rover representative to inspect the vehicle.

## **⚠ DANGER**

High speed impacts may cause serious injury or death irrespective of safety features fitted to a vehicle.

## **⚠ WARNING**

The air bag SRS cannot provide protection in some types of impact. Under these circumstances the only protection will be provided by a correctly worn seat belt.

## **AIR BAG OBSTRUCTION**

### **⚠ WARNING**

Do not obstruct the operation of the air bags by placing any part of your person or any objects in contact with, or close to, an air bag module. If the airbag inflates, objects or any part of your person could interfere with the inflation of the airbag or be propelled inside the vehicle, causing injury to the occupants.

Do not allow passengers to obstruct the operation of the air bags by placing feet, knees or any other part of the body, or any other objects in contact with, or in close proximity to, an air bag module.

Do not place objects between the air bag module and the seat occupant.

### **⚠ WARNING**

Do not use non-approved seat covers or accessory seat covers that have not been designed for use with air bags. If in doubt, consult your Land Rover Retailer/Authorized Repairer.

## **⚠ WARNING**

Ensure that a gap is maintained between the side of the vehicle, and the head and torso. This will enable unobstructed inflation of the curtain, and seat mounted side air bags.

## **⚠ WARNING**

Do not attach or position items on, or close to the roof lining, front seat backrests, or to an air bag cover, which could interfere with the inflation of the air bag or be propelled inside the vehicle, causing injury to the occupants.

**Note:** Unauthorized modification of the vehicle or parts may invalidate the vehicle's warranty.

Air bags cannot deploy correctly if they are obstructed. Examples of obstructions are:-

- Any part of an occupants body in contact with, or close to, an air bag cover.
- Objects placed on, or close to, an air bag cover.
- Clothing, sun screens, or other material hanging from grab handles.
- Clothing, cushions, or other material, covering seat mounted air bags.
- Seat covers which are not approved by Land Rover, or specifically designed for use with seat mounted air bags.

This list is not exhaustive and it remains the responsibility of the driver and passengers to ensure that the air bags are not obstructed in any way.

## **FRONT AIR BAGS**

The front passenger and driver air bags are able to deploy in two stages, depending on the severity of the frontal impact. In a severe impact, the air bags inflate fully to offer maximum protection. In a lesser impact, full deployment is not required, so the air bags are partially inflated.

## SEAT MOUNTED SIDE AIR BAGS

These are designed to protect the thorax region of the torso and will deploy only in the event of a side impact and then, only on the side of the impact.

## CURTAIN AIR BAGS

The curtain air bags deflate at a slower rate than the front or side air bags, to afford greater protection from serious head injuries.

### **⚠️WARNING**

**For the curtain air bags to deploy correctly, the roof lining and A post trim must be undamaged and fitted correctly. Any damage or suspect fitting should be referred to a Land Rover Retailer/Authorized Repairer for examination.**

*Note: Curtain air bags will not inflate as a result of frontal or rear impacts alone.*

## AIR BAG DEPLOYMENT EFFECTS

### **⚠️WARNING**

**When an air bag inflates, a fine powder is released. This is normal and not an indication of a malfunction. The powder may cause irritation to the skin and should be thoroughly flushed from eyes and any cuts or abrasions. This powder can cause breathing difficulties for asthma sufferers or other people with respiratory problems. If this occurs, get out of the vehicle as soon as it is safe to do so or get fresh air by opening a window. If breathing problems persist, seek medical attention.**

### **⚠️WARNING**

**Air bag deployment is accompanied by a very loud noise which may cause discomfort and temporary loss of hearing.**

### **⚠️WARNING**

**After inflation, some air bag components will be very hot. Do not touch the air bag components until they have cooled sufficiently.**

After inflation, the front and seat mounted side air bags deflate immediately. This provides a gradual cushioning effect for the occupants and also ensures that the driver's forward vision is not obscured.

## AIR BAG WARNING LAMP



The air bag warning lamp is mounted in the instrument pack and will illuminate as a bulb check when the ignition is turned on.

### **⚠️WARNING**

**Even with advanced air bags, children can be seriously injured or killed. Never place a child in any type of child restraint or booster seat in the front passenger seat. Children under the age of 13 should always ride in the rear.**

If any of the following warning indicator conditions occur, the vehicle should be checked by your Retailer immediately.

- The warning lamp fails to illuminate when the ignition is turned on.
- The warning lamp fails to extinguish within 6 seconds of the ignition being turned on.
- The warning lamp illuminates at any time other than the bulb check, as previously described.

## OCCUPANT DETECTION

The front passenger seat is fitted with an occupancy sensor system that determines if the seat is unoccupied, occupied by a person of low weight, a child seat or object, or is occupied by a heavier person or object.

The system consists of:

- A weight sensing pressure pad installed under the front passenger seat cushion. The sensor measures downward pressure/weight on the seat cushion.
- A seat belt tension sensor integrated into the anchor point of the front passenger seat belt.
- A control unit installed under the front passenger seat.
- An air bag status indicator lamp, mounted on the overhead control panel.

### **⚠️ WARNING**

**When checking the operational status of the front passenger air bag, ensure that the ignition is switched on.**



SL1756

There are three operational states:

Occupancy status	Passenger air bag status	Status lamp illuminated
Completely empty	Deactivated	No*
Child restraint or low weight occupant/object	Deactivated	Yes
Heavy occupant/object	Activated	No

\* It is possible to receive an intermittent status lamp condition with an empty seat. This is part of the adaptive behavior of the system and does not affect the status of the passenger air bag. If the status lamp remains illuminated when the seat is unoccupied or an adult is seated, contact your Retailer immediately.

**Note:** A very small child in a child seat may not activate the PASS AIR BAG OFF lamp. In this situation the first line of information in the table will be applicable.

## DANGER

Crash statistics show that children are safest when properly restrained in a child restraint system appropriate for their age and weight and secured in a rear seating position.

## DANGER

Do not use a child restraint on a seat protected by an operational air bag in front of it. Doing so presents a high risk of death or serious injury to the child in the event of an accident.

## AIR BAG SERVICE INFORMATION

### WARNING

Do not attempt to service, repair, replace, modify, or tamper with, any part of the SRS. This includes wiring or components in the vicinity of SRS components. Doing so may cause the system to trigger, or render the system inoperative, either of which may result in serious injury or death.

### WARNING

Do not use any electrical test equipment or devices in the vicinity of SRS components or wiring. Doing so may cause the system to trigger, or render the system inoperative, either of which may result in serious injury or death.

## WARNING

For your safety, all of the following operations should only be carried out by a Land Rover Retailer/Authorized Repairer, or suitably qualified person:-

- Removal or repair of any wiring or component in the vicinity of any SRS components.
- Installation of electrical, or electronic, equipment and accessories.
- Modification to the front or sides of the vehicle exterior.
- Attachment of accessories to the front or sides of the vehicle.

Always contact your Retailer if:

- An air bag inflates.
- The front or sides of the vehicle are damaged.
- Any part of the Air bag Supplementary Restraint System (SRS) shows signs of cracking or damage, including trim covering air bags.

## DISABILITY MODIFICATIONS

Occupants with disabilities which may require modifications of the vehicle, must contact a Retailer before any modifications are made.