

DISABILITY MODIFICATIONS

WARNING

Occupants with disabilities that may require the vehicle to be modified must contact a Land Rover Retailer/Authorized Repairer before any modifications are made.

Modifications may adversely affect the vehicle which can lead to loss of control, resulting in a crash.

(USA only) If you are considering modifying your vehicle in any way to accommodate a disability, for example by altering or adapting the driver's or passenger's seat(s) or air bag system, please contact:

Jaguar Land Rover North America LLC

Customer Relations Center

555 MacArthur Blvd

Mahwah

New Jersey 07430-2327

1-800-637-6837, option #9.

CALIFORNIA PROPOSITION 65 WARNING

WARNING

Engine exhaust, some of its constituents, and certain vehicle components contain or emit chemicals known to the State of California to cause cancer, and birth defects or other reproductive harm. In addition, certain fluids contained in vehicles and certain products of component wear contain or emit chemicals known to the State of California to cause cancer, and birth defects or other reproductive harm.

WARNING

Battery posts, terminals and related accessories contain lead and lead compounds. Wash hands after handling.

WARNING

Certain components of this vehicle such as air bag modules and seat belt pretensioners may contain Perchlorate Material - Special handling may apply for service or vehicle end of life disposal. See www.dtsc.ca.gov/hazardous_waste/perchlorate.

PARTS AND ACCESSORIES

Only use Land Rover approved parts and accessories.

WARNING

The use of non-approved parts and accessories, or the carrying out of non-approved alterations or conversions, may be dangerous and could affect the safety of the vehicle and occupants.

AIR BAG SYSTEM

WARNING

The components that make up the air bag system are sensitive to electrical or physical interference, either of which could easily damage the system and cause inadvertent operation or a malfunction of the air bag module.

To prevent malfunction of the air bag system always consult your Retailer before fitting any of the following:

- Electronic equipment such as a mobile phone, two-way radio or audio system.
- Accessories attached to the front of the vehicle.
- Any modification to the front of the vehicle.

- Any modification involving the removal or repair of any wiring or component in the vicinity of any of the air bag system components, including the steering wheel, steering column, instrument or facia panels.
- Any modification to the facia panels or steering wheel.

SERVICE INTERVALS

An upcoming service interval will be notified to the driver via the Driver Information Module, as either a distance or time left until service is due. Once the distance or time are exceeded, the display will show a negative value (-) to indicate that a service is overdue.

One or both types of service interval (distance and time) may be displayed.

PASSPORT TO SERVICE

Ensure your service provider signs and stamps the book after each service and inspection.

OWNER MAINTENANCE

NOTICE

Any significant or sudden drop in fluid levels, or uneven tire wear, should be reported to a qualified technician without delay.

In addition to the routine maintenance, a number of simple checks must be carried out more frequently.

DAILY CHECKS

- Operation of lamps, horn, turn signals, wipers, washers and warning lamps.
- Operation of seat belts and brakes.
- Look for fluid deposits underneath the vehicle that might indicate a leak.

WEEKLY CHECKS

- Engine oil level.
- Engine coolant check.
- Brake fluid level.
- Power steering fluid level.
- Screen washer fluid level.
- Tire pressures and condition.
- Operate air conditioning.

***Note:** The engine oil level should be checked more frequently if the vehicle is driven for prolonged periods at high speeds.*

DRIVING IN ARDUOUS CONDITIONS

When a vehicle is operated in extremely arduous conditions, more frequent attention must be paid to servicing requirements.

Arduous driving conditions include:

- Driving in dusty and/or sandy conditions.
- Driving on rough and/or muddy roads.
- Frequent wading.
- Frequent driving at high speeds in high ambient temperatures above 122°F (50°C).
- Frequent driving in severe cold weather below -40°F (-40°C).
- Frequent trailer towing.
- Driving in areas using road salt or other corrosive materials on the driving surface.

Contact a Land Rover Retailer for advice.

EMISSION CONTROL

Your vehicle is fitted with various items of emission and evaporative control equipment, designed to meet specific territorial requirements. You should be aware that unauthorized replacement, modification or tampering with this equipment by an owner or repair shop, may be unlawful and subject to legal penalties.

In addition, engine settings must not be tampered with. These have been established to ensure that your vehicle complies with stringent exhaust emission regulations. Incorrect engine settings may adversely affect exhaust emissions, engine performance and fuel consumption. They may also cause high temperatures, which will result in damage to the catalytic converter and the vehicle.

ROAD TESTING DYNAMOMETERS (ROLLING ROADS)

It is essential that any dynamometer testing is carried out only by a qualified person, familiar with the dynamometer testing and safety procedures practised by Land Rover Retailers.

SAFETY IN THE GARAGE

WARNING

If the vehicle has been driven recently, do not touch the engine, exhaust and cooling system components until the engine has cooled.

WARNING

Never leave the engine running when the vehicle is in a garage. Exhaust gases are poisonous and can cause unconsciousness and death if inhaled.

WARNING

Do not work beneath the vehicle with the wheel changing jack as the only means of support.

WARNING

Keep your hands and clothing away from drive belts, pulleys and fans. Some fans may continue to operate after the engine has stopped.

WARNING

Remove metal wrist bands and jewellery, before working in the engine compartment.

WARNING

Do not touch electrical leads or components while the engine is running, or with the ignition turned on.

WARNING

Do not allow tools or metal parts of the vehicle to make contact with the battery leads or terminals.

FUEL SYSTEM

WARNING

Under no circumstances should any part of the fuel system be dismantled or replaced by anyone other than a suitably qualified vehicle technician.

WARNING

Ensure sparks and naked lights are kept away from the engine compartment.

WARNING

Wear protective clothing, including, where practicable, gloves made from an impervious material.

POISONOUS FLUIDS

Fluids used in motor vehicles are poisonous and should not be consumed or brought into contact with open wounds.

For your own safety, always read and obey all instructions printed on labels and containers.

USED ENGINE OIL

Prolonged contact with engine oil may cause serious skin disorders, including dermatitis and cancer of the skin. Always wash thoroughly after contact.



It is illegal to pollute drains, water courses or soil. Use authorized waste disposal sites to dispose of used oil and toxic chemicals.

OPENING AND CLOSING THE HOOD



SL1292

Opening

1. Pull the release lever, located in the left-hand front footwell.
2. Lift the hood safety catch lever, located below the center point of the hood, then raise the hood.

Closing

⚠WARNING

Do not drive with the hood retained by the safety catch alone.

1. Lower the hood until the safety catch engages. Using both hands, press the hood down until the catches click.
2. Check that both catches are engaged, by trying to lift the front edge of the hood.

ENGINE COMPARTMENT OVERVIEW

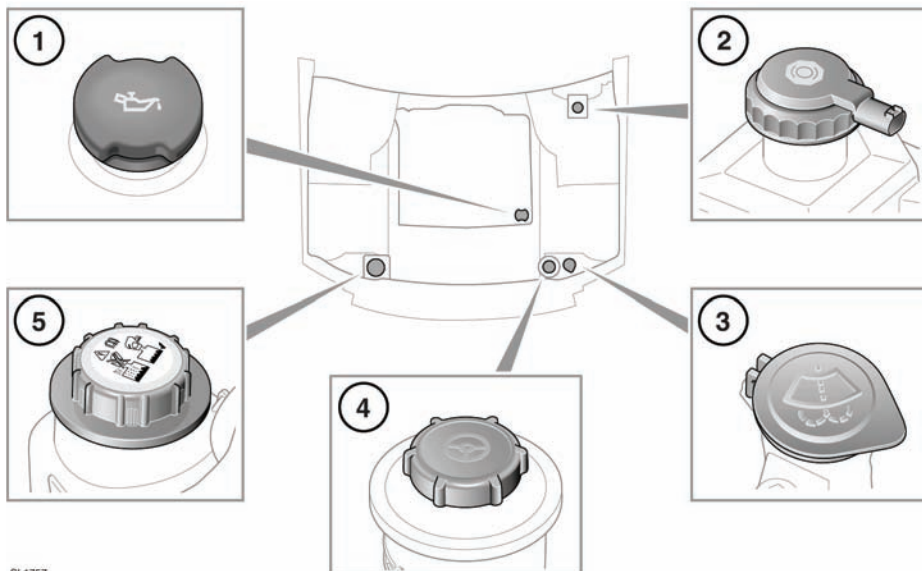

SL1757

1. Engine oil filler cap.
2. Brake fluid reservoir cap.
3. Windshield washer fluid filler cap.
4. Power steering fluid filler cap.
5. Engine coolant filler cap.

Note: For top-up procedures see *Fluid level checks*.

⚠ WARNING

While working in the engine compartment, always observe the safety precautions. See **SAFETY IN THE GARAGE** (page 188).

⚠ WARNING

Do not drive if there is a possibility that leaked fluid will come into contact with a hot surface, such as the exhaust.

CHANGING A BULB

⚠ WARNING

If the lighting has just been switched off, give the bulbs time to cool. Handling them when hot may cause personal injury.

NOTICE

Before attempting to replace a bulb, ensure that both the affected lamp and the vehicle's ignition are turned off. If the circuit remains live, a short circuit can occur which may damage the vehicle's electrical system.

NOTICE

Always replace bulbs with the correct type and specification. If you are in any doubt contact your Land Rover Retailer/Authorized Repairer for advice. **211, BULB SPECIFICATION CHART**

Note: In certain territories it is a legal requirement to carry spare bulbs. A replacement bulb kit is available as an approved accessory from your Retailer.

Note: After replacing a headlamp bulb, headlamps alignment should be checked with the appropriate equipment.

HEADLAMP - BULB IDENTIFICATION

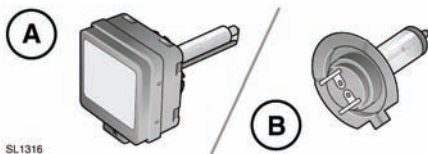

SL1316

- A. Xenon bulb.
- B. Halogen bulb.

HALOGEN BULBS

Dependent on vehicle specification, halogen bulbs may be used for high beam, low beam, and front fog lamps.

NOTICE

Take care not to touch this type of bulb with your fingers; always use a cloth to handle them. If necessary, clean the bulb with methyl hydrate or denatured alcohol to remove fingerprints.

XENON LAMPS

⚠ WARNING

High voltage is required to ignite the gas and metal vapour which are used to power Xenon lamps. Contact with this voltage can cause serious injury. Replacement or maintenance of Xenon lamps should be carried out only by suitably qualified personnel.

⚠ WARNING

Xenon lamp units operate at a very high temperature. Ensure that the lamp units have cooled before attempting to touch them.

⚠ WARNING

Xenon lamp units contain Mercury which is highly toxic and can be extremely harmful.



Seek advice about the correct disposal of Xenon lamp units from a Land Rover Retailer or your local authority.

XENON HEADLAMP BULB

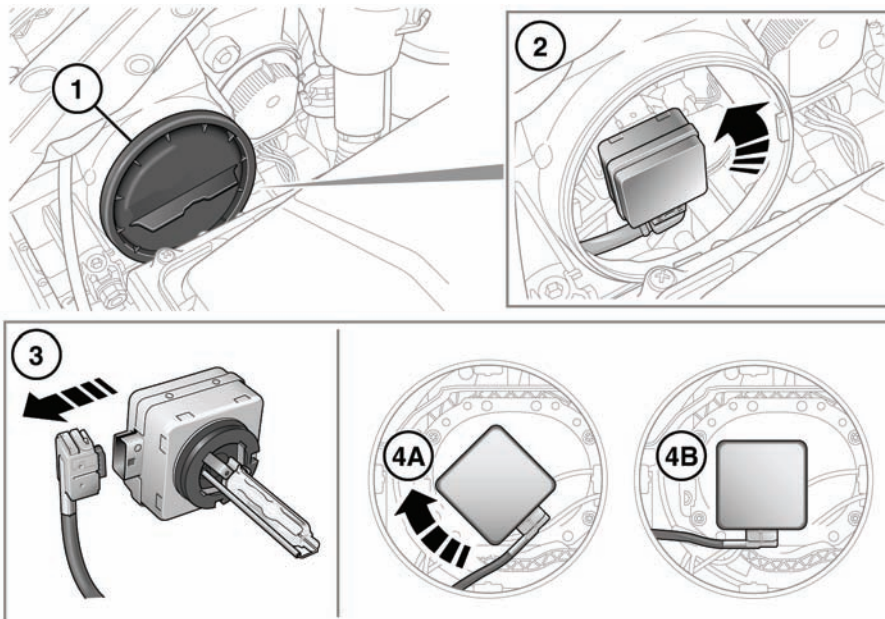

SL1409

1. Twist and lift off the cap.
2. Rotate the bulb unit counter clockwise and carefully withdraw the unit.
3. Pull off the electrical connector.
4. Connect the new bulb unit.
 - A. Carefully insert into the headlamp unit as indicated.
 - B. Twist clockwise to lock the bulb in place. Replace the cap.

HALOGEN HEADLAMP BULB

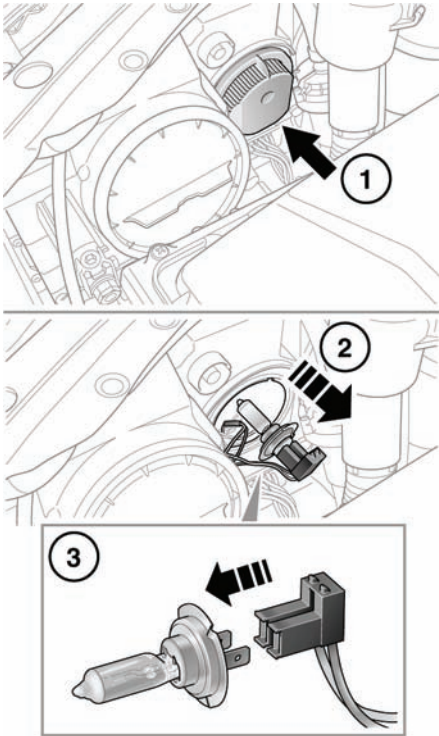

SL1412

1. Twist and lift off the cap.
2. Pull out the holder and bulb.
3. Release the bulb from the holder.
4. Insert the new bulb and repeat the above procedure in reverse order.

SIDE REPEATER LAMP BULB

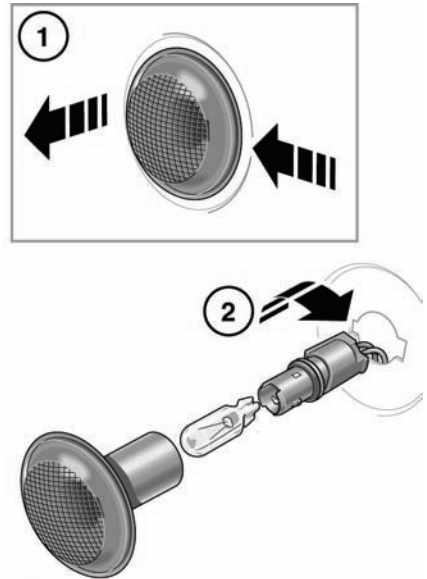

SL1381

1. Push the lens unit firmly towards the rear of the vehicle and prise out the leading edge. Release the rearward pressure, allowing the lens unit to be released from its fixing point.
 2. Twist to release the bulb holder from the lens unit. Pull the bulb from its socket.
- Insert the new bulb using the previous process in reverse order.

FRONT FOG LAMP BULB

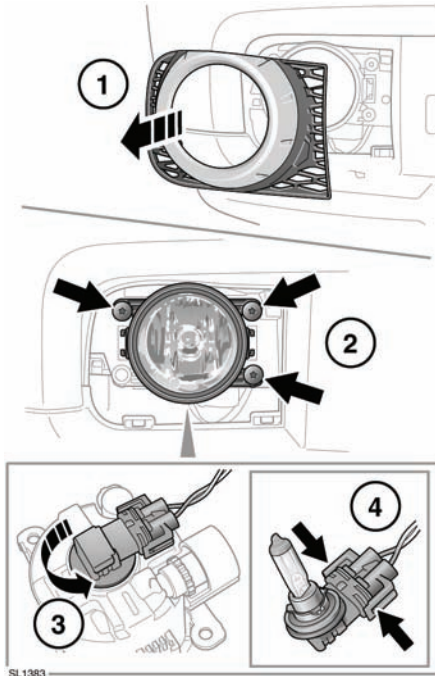

1. Insert a screwdriver through the lower part of the headlamp grille then lift and release the bottom securing tabs. Pull the grille forward and remove.
2. Undo the three retaining screws, and remove the lamp unit.
3. Rotate the bulb holder counter clockwise and remove from the lamp unit.
4. Press the two clips together and remove the electrical connector.

Insert the new bulb using the previous process in reverse order.

REVERSING LAMP BULB

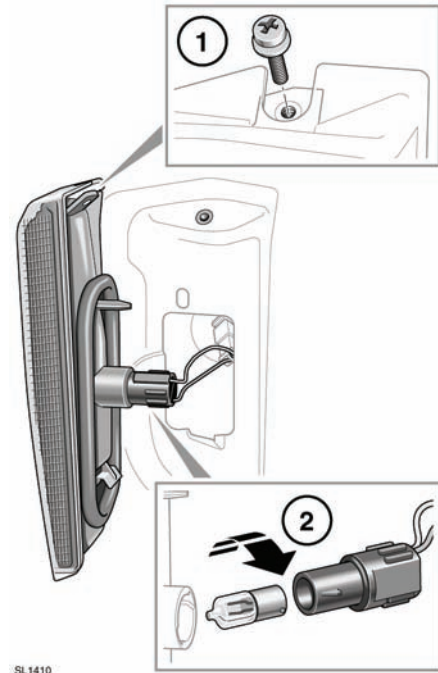

The lamps are located either side of the license plate.

1. With the tailgate open, remove the screw from the unit. Pull the unit carefully away from the vehicle.
2. Twist and pull the bulb holder from the lamp unit. Pull the bulb from the electrical connector.

Ensure that the lamp unit is placed face down on a flat surface covered in soft material to prevent damage.

Insert the new bulb using the previous process in reverse order.

LICENCE PLATE LAMP BULB

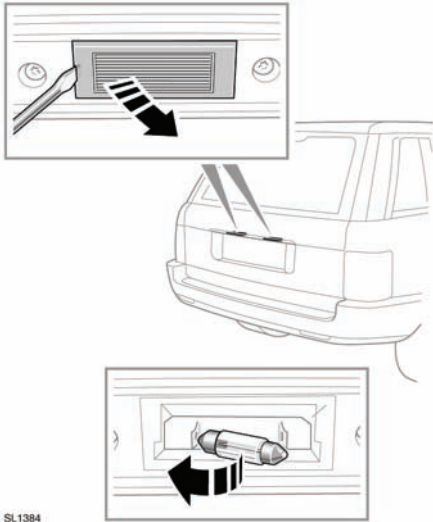

SL1384

Follow the steps illustrated. Insert a new bulb and refit the components.

INTERIOR LAMPS - BULB CHANGING

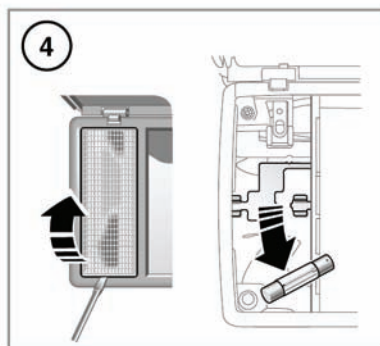
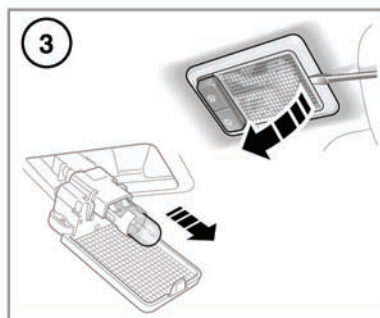
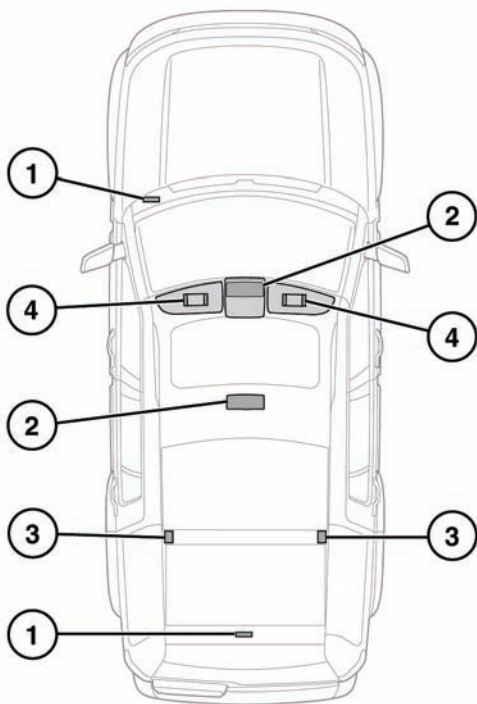
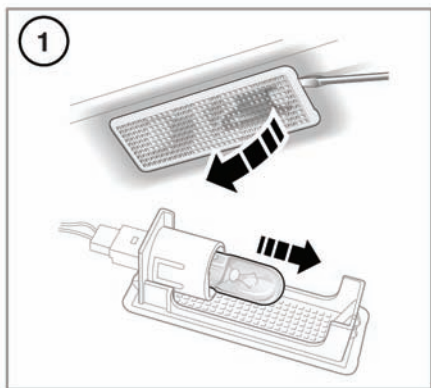

SL1149

Follow the steps illustrated. Insert a new bulb and refit the components.

1. Footwell and puddle lamps.
2. Courtesy lamp and map lamps.
3. Rear courtesy lamps.
4. Vanity mirror lamps.

SUNROOF RESET

If the battery is disconnected or the power supply is interrupted while the sunroof is partially open, it will need to be recalibrated.

When the battery is reconnected or the power supply is restored, recalibrate the sunroof as follows:

1. Switch the ignition on.
2. With the sunroof closed, press and release the front of the switch. The sunroof will move to the tilt position.
3. Press the front of the sunroof switch and hold for 20 seconds.

The sunroof can now be operated as normal.

SERVICE DATA RECORDING

Service data recorders in your vehicle are capable of collecting and storing diagnostic information about your vehicle. This potentially includes information about the performance or status of various systems and modules in the vehicle such as engine, throttle, steering or brakes.

In order to properly diagnose and service your vehicle, Land Rover and service and repair facilities may access vehicle diagnostic information through a direct connection to your vehicle.

PARTS AND ACCESSORIES

⚠ WARNING

The use of non-approved parts and accessories, or the carrying out of non-approved alterations or conversions, may be dangerous and could affect the safety of the vehicle and occupants and also invalidate the terms and conditions of the vehicle warranty.

⚠ WARNING

Land Rover will not accept any liability for death, personal injury or damage to property which may occur as a result of fitment of non-approved accessories or the carrying out of non-approved conversions to Land Rover vehicles.

CLEANING THE EXTERIOR

NOTICE

Following cleaning of the vehicle exterior (particularly with a pressure washer), it is recommended that the vehicle is taken for a short drive to dry out the brakes.

NOTICE

Some high pressure cleaning systems are sufficiently powerful to penetrate door/window seals and damage trim and door locks. Never aim the water jet directly at the engine air intake, heater air intakes, body seals (doors, sunroof, windows etc.) or at any components which may be damaged (lights, mirrors, exterior trim etc.).

NOTICE

Do not use a power wash system in the engine bay area as it may cause damage.

NOTICE

Remove any heavy deposits of mud and dirt with a hose before washing the vehicle.

NOTICE

Substances which are corrosive, such as bird droppings and tree resin, can damage the vehicle's paintwork and should be removed as soon as possible.

NOTICE

Ensure that you read and comply with all warnings and product instructions supplied with any cleaning products.

NOTICE

Never use cleaning products that are not approved for use on vehicles.

Note: Do not apply polish to any unpainted areas of the bumper mouldings. It will become ingrained in the textured finish.

USING SPIRIT CLEANER

Stubborn stains such as tar spots and grease may require the use of white spirit. After use, ensure the area is washed with warm soapy water to remove all traces of the spirit.

UNDERBODY MAINTENANCE

Regularly flush the underbody with plain water, and pay particular attention to areas where mud and debris collect.

If damage or corrosion are detected, have the vehicle checked by a Land Rover Retailer as soon as possible.

CLEANING AFTER OFF-ROAD DRIVING

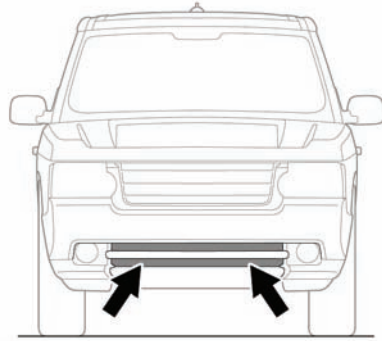

SL1822

NOTICE

Ensure that the areas around air intakes and the front grille are clean and clear of debris. Pay particular attention to the lower grille and radiator. Failure to do so may cause the engine to overheat, leading to severe engine damage.

Ensure that the vehicle underside is cleaned as soon as possible after driving off-road.

PAINT DAMAGE

Minor chips and scratches can be touched up using materials available from a Land Rover Retailer. Your VIN code will give your supplier the color reference.

CLEANING THE INTERIOR

⚠ CAUTION

Some cleaning products contain substances that are harmful and can cause health problems if used incorrectly and may cause damage to the vehicle interior. Ensure that you read the manufacturer's instructions carefully.

PLASTIC AND CLOTH

WARNING

Do not polish the instrument panel. Polished surfaces are reflective, and may interfere with the drivers view.

Clean plastic or cloth faced surfaces with warm water and non-detergent soap. Then wipe clean with a soft cloth.

LEATHER

NOTICE

Only use cleaning products specifically designed for use on leather. Do not use chemical, alcohol, or abrasive materials, as they will cause rapid deterioration of the leather. The use of products which are not approved will invalidate your warranty. If you are in any doubt as to which products to use, consult your Land Rover Retailer/ Authorized Repairer.

NOTICE

Some materials/fabrics are prone to dye transfer, which can cause unsightly discoloration of lighter colored leathers. Affected areas should be cleaned and re-protected as soon as possible.

Leather should be cleaned and protected at least every six months.

To prevent ingrained dirt and staining, inspect the seat upholstery regularly and clean every one to two months as follows:

1. Wipe off fine dust from the seat surfaces using a clean, damp, non-colored cloth. Change frequently to a clean area of cloth to avoid abrasive action on the leather surface. Avoid over wetting the leather.

2. If this is not sufficient, use a cloth which has been dampened with warm soapy water and then wrung out. Use only mild non-caustic soap.
3. Use Land Rover leather cleaner for heavily soiled areas. Dry off and rub the with a clean soft cloth, changing surfaces regularly.

Use Land Rover leather cleaner several times a year to maintain the leather's suppleness and appearance. The cleaner will nourish and moisturise and help to improve the surface protection film against dust and substances.

- Dark clothing may stain leather seats just like other upholstery products.
- Sharp objects such as belts, zippers, rivets etc can leave permanent scratches and scratch marks on the leather surface.
- Unless spillages such as tea, coffee or ink are washed away immediately, permanent staining may have to be accepted.
- Do not use a cleaning product that is not specifically for use in a vehicle. Such products may give an initial impressive appearance but their use will lead to rapid deterioration of the leather and will invalidate the warranty.

If a valet service is used, ensure that the specialist concerned is aware of, and follows, these instructions precisely.

SEAT BELTS

WARNING

Do not allow any water, cleaning products, or fabric from cloths to enter the seat belt mechanism. Any substance which enters the mechanism may affect the performance of the seat belt in an impact.

Extend the seat belts fully, then use warm water and a non-detergent soap to clean. Allow the seat belts to dry naturally while fully extended.

Note: When cleaning a seat belt, take the opportunity to examine the webbing for damage/wear. Any wear or damage should be reported to, and rectified by, a Land Rover Retailer.

AIR BAG MODULE COVERS

⚠WARNING

Air bag covers should only be cleaned using a slightly dampened cloth, and a small amount of upholstery cleaner.

⚠WARNING

Do not allow the air bag covers, or surrounding areas, to become contaminated with liquids. Any substance which enters the mechanism can prevent correct deployment of an air bag during an impact.

INSTRUMENT PANEL, TOUCH SCREEN AND AUDIO SYSTEM

- Clean with a lightly moistened cloth.
- Do not use chemical agents or domestic cleaners.
- Do not allow sharp, hard or abrasive objects to make contact with screens.
- Avoid exposing screens to direct sunlight for long periods.
- To prevent errors occurring, ensure that only one finger at a time is in contact with the touch screen.
- Do not use excessive pressure.

WIPER BLADE REPLACEMENT

Fit only replacement wiper blades that are identical to the original specification.

Front wiper blade: The blade is locked in position by a locking tab on the wiper arm. Push the tab to unlock. Fitting a new blade is a reversal of the removal process.‘

Rear wiper blade: The blade is inaccessible in its parked position. Remove as follows;

1. Operate the rear wiper.
2. When the blade is in a near vertical position, open the upper tailgate. The wiper will stop.
3. Turn the ignition off.
4. Lower the upper tailgate and lift the wiper arm away from the glass.
5. Pivot the blade assembly away from the arm.
6. Press the tab (arrowed in illustration) to release the blade assembly. Slide it off the end of the wiper arm. Carefully lower the arm to the glass.

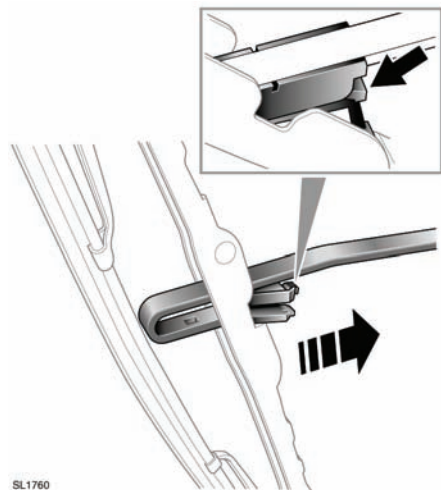

SL1760

Reverse the procedure to fit the new blade assembly. When the upper tailgate is closed and ignition is turned on, the rear wiper will return to the parked position.

BLOCKED WASHER JETS

CAUTION

Do not operate the washer jets during unblocking or adjustment. Windshield washer fluid may cause irritation to the eyes and skin. Always read and observe the washer fluid manufacturers instructions.

If a washer jet becomes blocked, use a thin strand of wire to unblock the jet by inserting the wire into the jet. Ensure that the wire is completely removed after unblocking. The washer jet position may also be adjusted by inserting the point of a needle into the jet and gently repositioning it.

The rear screen jets located in the wiper arm are not adjustable.