

RECOMMENDED TOWING WEIGHTS

Maximum permissible towing weights	On-road	Off-road
Unbraked trailers	750 kg (1650 lbs)	750 kg (1650 lbs)
Trailers with overrun brakes	2000 kg (4400 lbs)*	750 kg (1650 lbs)
Nose weight	150 kg (330 lbs)	-
Nose weight - Australia only	350 kg (770 lb)	-

* For diesel vehicles in Algeria, Egypt, India, Libya, Morocco, Pakistan and Tunisia, the maximum permissible towing weight for a trailer with overrun brakes is 1500 kg (3307 lbs).

See **162, WEIGHTS**, for details of the Gross Vehicle Weight (GVW), Gross train weight, axle weights and maximum payload.

Note: When towing, the maximum permissible Gross Vehicle Weight can be increased by a maximum of 100 kg (220 lbs) provided that the road speed is limited to 100 km/h (60 mph).

Note: When calculating rear axle loading, remember that the trailer nose weight, the load in the vehicle's luggage area, weight on the roof rack, and the weight of rear seat passengers must all be added together.

TRAILER ELECTRICAL CONNECTION



Only connect approved electrical circuits, which are in good condition, to the trailer socket.



When a trailer electrical connection is made and the vehicle's direction indicators are used, the trailer warning indicator will flash in time with the direction indicators.

TOWING A TRAILER



Never exceed the maximum weights for either the vehicle, or the trailer. Doing so can cause accelerated wear and damage to the vehicle. It can also adversely affect vehicle stability and braking which in turn can lead to loss of control and increased braking distance, resulting in a rollover or crash.



To preserve handling and stability, only fit Land Rover approved towing accessories.



Never use towing eyes or lashing points to tow a trailer. They have not been designed for this purpose and doing so may cause them to fail, resulting in injury or death.

LEVELLING

To maintain vehicle stability, it is essential that the trailer is loaded so that it remains parallel to the ground. This is particularly important when towing twin axled trailers.

ESSENTIAL TOWING CHECKS

- When calculating the laden weight of the trailer, remember to include the weight of the trailer, plus the weight of the load.
- If the load can be divided between the vehicle and trailer, loading more weight into the vehicle will generally improve stability. Do not exceed the vehicle's weight limits.
- Increase rear tyre pressures of the towing vehicle to those for maximum vehicle loading conditions.
- Ensure trailer tyre pressures are set to trailer manufacturer's recommendations.
- If the vehicle is loaded to maximum Gross Vehicle Weight (GVW) the nose weight is limited to 150 kg (330 lbs). See **162, WEIGHTS**.
- If it is necessary to increase the nose weight up to a maximum of 250 kg (550 lbs), the vehicle load should be reduced accordingly. This ensures that the GVW and maximum rear axle load are not exceeded.
- Ensure that a suitable breakaway cable or secondary coupling is used. Refer to the trailer manufacturer's instructions for guidance.
- Ensure that the tow ball is secure.
- Check the operation of all trailer lights.



Do not loop the breakaway cable over the tow ball as it may slide off.



Do not exceed the Gross Vehicle Weight (GVW), maximum rear axle weight, maximum trailer weight, or nose weight. Exceeding any of these limits could cause instability and loss of control.

Australia only:

- **Tyre pressures** - Increase rear pressures of towing vehicle to those for maximum Gross Vehicle Weight conditions.
- **Nose weight** - Must be a minimum of 7% of gross caravan/trailer weight, up to a maximum of 350 kg (722 lb).

**TOW BAR MOUNTING POINTS
DIMENSIONS**

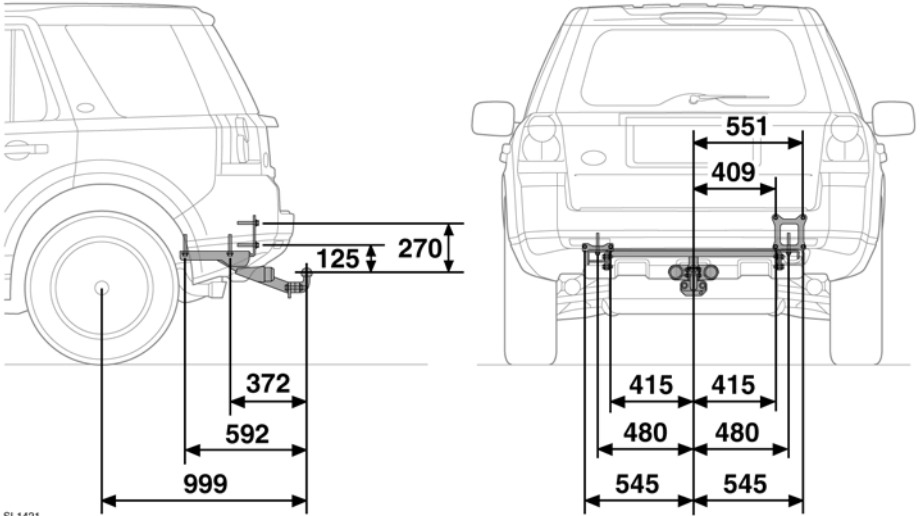

SL1421