

# Entering the vehicle

## UNLOCKING THE VEHICLE

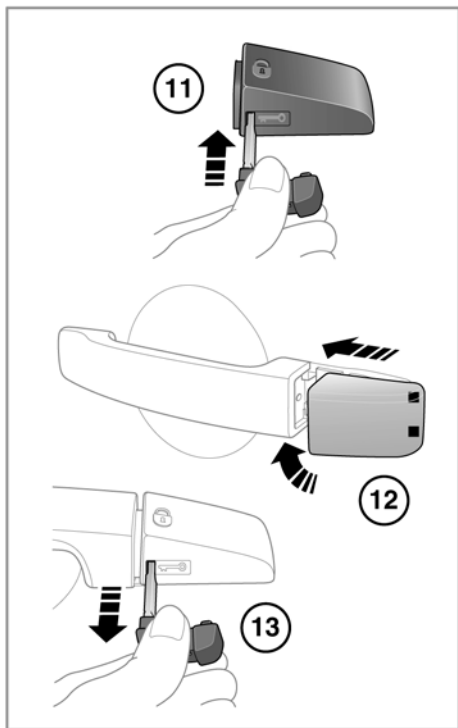

SL1005

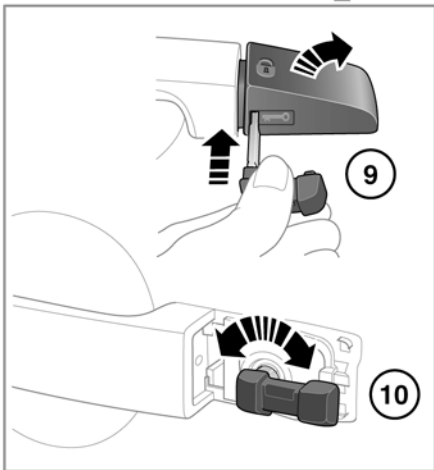
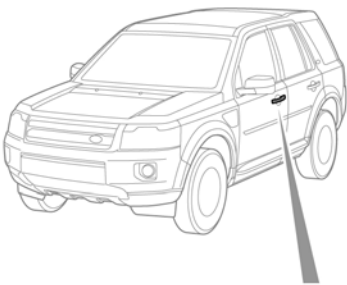
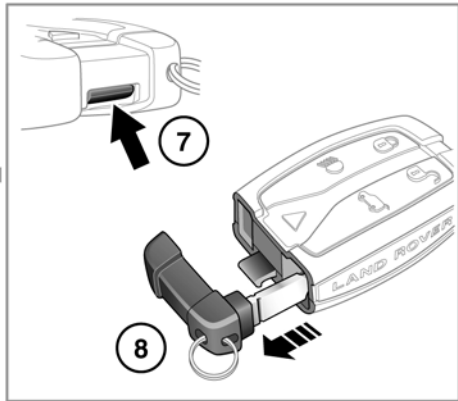
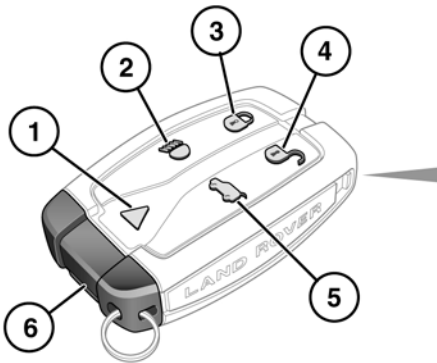

**To prevent accidental operation, never leave the remote control in the vehicle if children or animals are also left in the vehicle.**

**Note:** The operational range of the remote control will vary considerably depending on atmospheric conditions and interference from other transmitting devices.

**Note:** A replacement remote control can only be obtained from your Land Rover Dealer/ Authorised Repairer. The Dealer will require proof of ownership.

Notify your Dealer immediately if a remote control is lost or stolen.

## 1. Panic alarm.

- Press and hold for 3 seconds (or press 3 times within 3 seconds) to activate the horn and the hazard lamps.

**Note:** The horn and hazard lamps will switch off automatically after approximately 2 minutes and 45 seconds.

- Once active for more than 5 seconds, the alarm can be cancelled by pressing the button and holding for 3 seconds (or pressing 3 times within 3 seconds).
- The emergency alarm will also be cancelled if a remote control is docked.

## 2. Approach lighting.

- When approaching the vehicle during darkness, press to switch on the approach illumination. Press again to turn the approach lamps off.



The approach illumination period set at the factory is 30 seconds.

This delay period may be configured by your Land Rover dealer.

## 3. Lock.

- Press to lock the vehicle.

## 4. Unlock.

- Press briefly to unlock the vehicle and deactivate the alarm. The hazard warning lamps will flash twice to indicate that the vehicle is unlocked and the alarm has been deactivated. The interior lamps will illuminate to assist entry to the vehicle

## 5. Tailgate release.

- Press briefly to release the tailgate. The vehicle security system will remain active while the tailgate is open but intrusion and inclination sensing systems will be disabled. On closing of the tailgate, the hazard warning lamps will flash after a few seconds to confirm the full alarm system has been reactivated (if previously armed).

## 6. Emergency key blade.

## 7. Emergency key blade release tab.

## 8. Slide out to expose emergency key blade.

## 9. Fully insert the emergency key blade to remove cover.

## 10. Fully insert the emergency key blade into the lock and rotate to unlock the door.

## 11. Fully insert the emergency key blade into the lock cover.

## 12. Locate the rear of the lock cover using the tabs and close the cover.

## 13. Remove the emergency key blade from the cover.

**Note:** When the door is opened the alarm will begin to sound. To silence the alarm, dock the remote control.

## GLOBAL OPENING

Press and hold the unlock button for 3 seconds to unlock the vehicle and open all of the windows.

## AUTOMATIC RELOCKING

If a door or the tailgate are not opened within 1 minute of unlocking the vehicle, doors will lock again automatically.

## SINGLE/MULTI-POINT ENTRY

When you press the unlock button, your vehicle will unlock in one of two ways:

1. Single Point Entry: Unlocks the driver's door and fuel filler flap only. A second press is required to unlock the remaining doors and the tailgate.
2. Multi Point Entry: Unlocks all doors, fuel filler flap and the tailgate on the first press.

Single point entry can be disabled on individual remote controls by unlocking the vehicle then simultaneously pressing and holding the lock and unlock buttons for 3 seconds. The vehicle will lock and then unlock and the hazard warning lights will flash twice to confirm the change. You can now unlock all doors with a single press. Repeating the procedure will re-enable Single point entry.

## STEERING COLUMN LOCK



During vehicle recovery, the remote control must remain docked.

Your vehicle is fitted with an electronic steering column lock. The column unlocks when the remote control is docked.

Any malfunction of the steering column lock will be indicated by the message **STEERING COLUMN LOCKED** being displayed in the message centre. If this occurs:

1. Lock and then unlock the vehicle using the remote control.
2. Try again to unlock the steering column lock, by turning the steering wheel gently to the left and right.

3. If the problem persists, seek qualified assistance immediately.

## REMOTE CONTROL BATTERY

The remote batteries are charged automatically when the remote is docked and the engine is running. For this reason it is recommended that each remote is used for a minimum of four hours every six months. This will ensure that the batteries remain charged ready for use.