

## CONTROLS

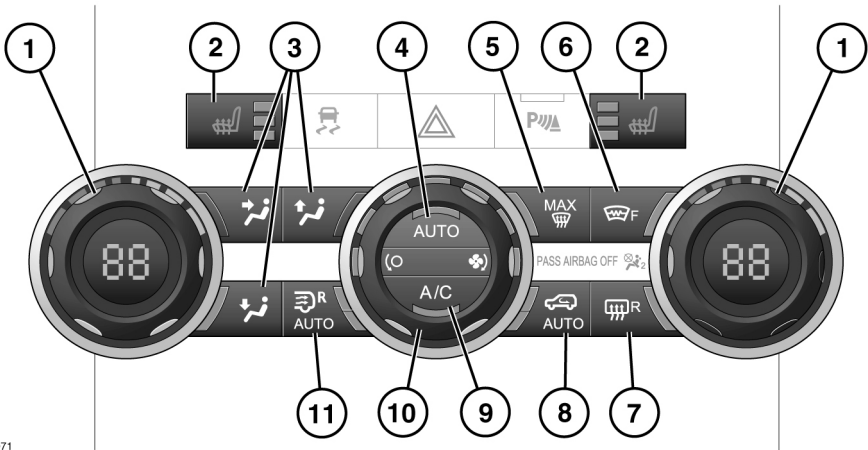

SL1071

1. Temperature controls.
2. Seat heaters: Press once to turn on high, twice to turn on low, and a third time to turn off.
3. Air distribution buttons.
4. Auto mode.
5. Defrost mode.
6. Heated front windscreen.
7. Heated rear screen.
8. Air recirculation control
9. Air conditioning on/off: With air conditioning off, the system operates in economy mode, improving fuel economy.  
*Note: Using the system without air conditioning for long periods can cause the windows to mist.*
10. Blower control:  
Rotate to adjust blower speed.  
Rotate fully anticlockwise to turn the climate control system off.
11. Rear environment.

**Note:** The indicator lights in the switches will illuminate when the function is selected.

**Note:** In low temperatures it is advisable to close the centre face level vent and direct air flow from the outer face level vents towards the side windows. This will help to keep the windows clear of ice.

### AUTO MODE

Press AUTO to select automatic operation.

The system will adjust the heat output, blower speed, air intake and airflow distribution to maintain the selected temperature(s) and reduce misting without further adjustments.

The air distribution and blower controls may be operated independently to override Auto mode. If you do this, the indicator lamp on the AUTO switch will go out. Press **AUTO** again to return to automatic operation.

**Note:** The system will not achieve a temperature differential from left to right of more than 4°C (7°F).

# Heating and ventilation

## AIR DISTRIBUTION CONTROL

Press to select the desired distribution setting:



Windscreen and side window vents



Face level vents



Foot level vents

**Note:** More than one setting may be selected at a time to achieve the desired distribution.

## RECIRCULATION



When selected, the air is recirculated inside the vehicle. This helps to maintain a high or low temperature, and is useful for preventing fumes entering the vehicle.

**Note:** The windows can mist if recirculation is used for long periods.

## RECIRCULATION WITH POLLUTION SENSOR



Press once to activate air recirculation. Press again to activate automatic air recirculation.

In automatic mode, air recirculation is regulated to achieve optimum air conditioning performance.

Press a third time to switch off.

**Note:** The windows can mist if recirculation is used for long periods.

## MAXIMUM DEFROST PROGRAM



Press to remove frost or heavy misting from the front screen. The system will automatically adjust the blower output for maximum clearing, in addition the front and rear screen heaters will be activated. Press again to switch off defrost mode. The screen heaters will remain on.

## REAR ENVIRONMENT



The rear environment unit provides climate control to the rear passengers.

- Press once to control the rear heating and air conditioning using the front controls only. The lower amber lamp is illuminated.
- Press a second time to allow the rear passengers to have manual control. The upper amber light is illuminated.
- Off: press a third time to switch off.

**Note:** Do not obstruct the vent on the side of the rear quarter panel.

## HEATED WINDSCREENS



Heated windscreen



Heated rear screen

Press button to operate the required screen heater. The screen heater(s) will operate for a predetermined timed period before automatically switching off.

The screen heaters will be automatically switched on if defrost mode is activated or if the external air temperature is low.



Do not attach labels to the rear screen. Do not scrape or use abrasive materials to clean the inside of the screen.

## HEATED MIRRORS

The heated external rear view mirrors operate automatically according to the external temperature and windscreen wiper operation.

## REAR PASSENGER CLIMATE CONTROLS

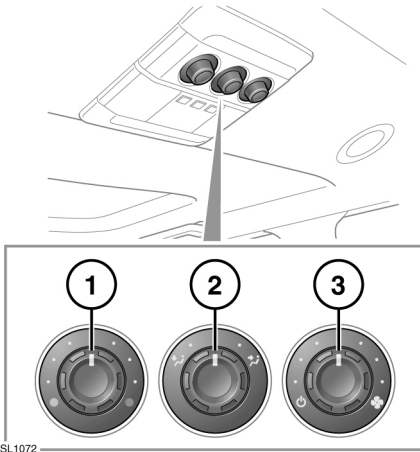

SL1072

1. Temperature control:  
Clockwise rotation increases the temperature.
2. Distribution control:  
Turn to the relevant icon to direct airflow. The control may be turned to a position between icons to split airflow between different vents.
3. Blower control.

**Note:** These controls only operate when the rear environment button is pressed twice, enabling rear manual operation.

## AUXILIARY HEATER

Your vehicle may be fitted with an auxiliary heater which is powered by fuel drawn from the vehicle's tank. The heater only operates at low ambient temperatures, and is controlled by the Timed climate control system.

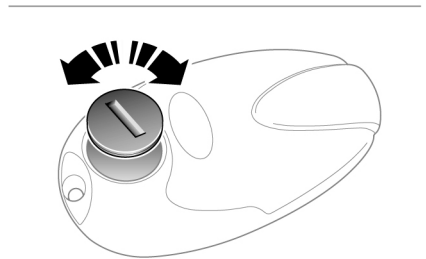
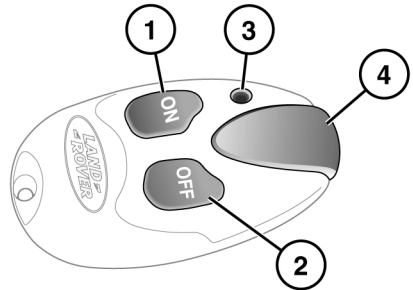

SL1074

The remote control has an approximate range of 100 m. There is no need to point the antenna at the vehicle.

1. On button.
2. Off button.
3. LED (operation indicator).
4. Antenna.

**Note:** Avoid touching the antenna when operating the **ON** or **OFF** button.

When the heater is operating exhaust fumes from the heater may be visible exiting from under the front of the vehicle. This is normal, and not a cause for concern.



**Do not operate the auxiliary heater when refuelling the vehicle. Doing so may cause fuel vapours to combust causing a fire/explosion.**



**Do not operate the auxiliary heater whilst the vehicle is in an enclosed space. Doing so can cause a build up of highly toxic fumes which may cause unconsciousness or death.**

## REPLACING THE BATTERIES

With the back of the remote control facing upwards, use a coin or similar implement to rotate the battery cover. Lift the cover off to reveal the battery compartment. Remove the old battery and, ensuring that the correct polarity is maintained, insert a replacement 3.3 volt, CR1/3N battery. Replace the cover and rotate it to lock it closed.

## TIMED CLIMATE CONTROL

The system provides a comfortable temperature inside the cabin in advance of driver and passengers entering. Dependent on the external temperature, the system draws in fresh air to cool the cabin, or operates the auxiliary heater to warm it.

The auxiliary heater is also operated to warm the engine and aid starting in very cold conditions.

The timed climate control system may be operated by either the touch screen or the remote handset.

## SWITCHING ON

Press and hold the **ON** button for approximately two seconds. The LED will illuminate to confirm that an automatic heating program has been initiated. The LED flashes once every 2 seconds to indicate that the heater is active.

The heating program will continue for 30 minutes, when it will switch off automatically to prevent the vehicle battery from discharging. It also turns off automatically if the engine is started.

The system may not operate, or will switch off automatically, if:

- If the fuel level is low.
- If the vehicle's battery charge is low.
- If the coolant temperature is at or above its required temperature.

The LED indicator, contained in the remote control, signals various states and conditions for the heater as follows:

- Illuminates green for 2 seconds when the **ON** button is pressed, to indicate that heater operation has been requested.
- Illuminates red for 2 seconds when the **OFF** button is pressed, to indicate that the heater has stopped.
- Flashes green or red for 2 seconds when the on or off buttons are pressed, to indicate that the signal was not received.
- Illuminates orange for 2 seconds before showing green or red, to indicate that the remote battery is low.
- Flashes orange for 5 seconds to indicate that the signal was not received and the remote battery should be replaced.

## ADDITIONAL REMOTES

Additional remote controls can be programmed to operate the heater. A maximum of 3 remotes can be programmed to each vehicle. You should contact your Land Rover Dealer to purchase additional remotes and have them programmed to your vehicle.

## USING THE TOUCH SCREEN

The touch screen can be used to either, program preset activation times for the timed climate control system, or to operate the system manually.

**Note:** *When activated, the heating program will operate for 30 minutes before being automatically switching off, to prevent the vehicle battery being discharged.*

The system can be programmed to operate once or twice in any 24 hour period. If the vehicle is used each day the system will continue to operate each day until cancelled. If the vehicle is not used for 24 hours, this cycle will be cancelled.

**Note:** *Operation of timed climate control will resume the next time the ignition is turned on.*

When the system is operating, the LED in the AUTO button will flash.

**Note:** *The system will cease operation if the engine is started.*

## SETTING A TIME FOR TIMED CLIMATE OPERATION.

To preset a time for timed climate operation, touch the Timed climate icon on the touch screen Home menu. Alternatively, this menu can be accessed from the Vehicle settings menu.

Touch the **Set** icon next to the timer you would like to program.

Touch the up or down arrows to select the time you want the system to begin operation. Then select **OK**.

The screen will now show the time at which the system is set to activate. If required, set the time for the other timer using the same process.

A previously set time may be cancelled by switching on the ignition.

The timed climate screen will update to show **OFF**, next to the respective timer.

**Note:** *The time format shown is determined by the time settings currently selected in the System Settings menu. See 109, PERSONALISING THE SYSTEM SETTINGS.*