

# Entering the vehicle

## UNLOCKING THE VEHICLE

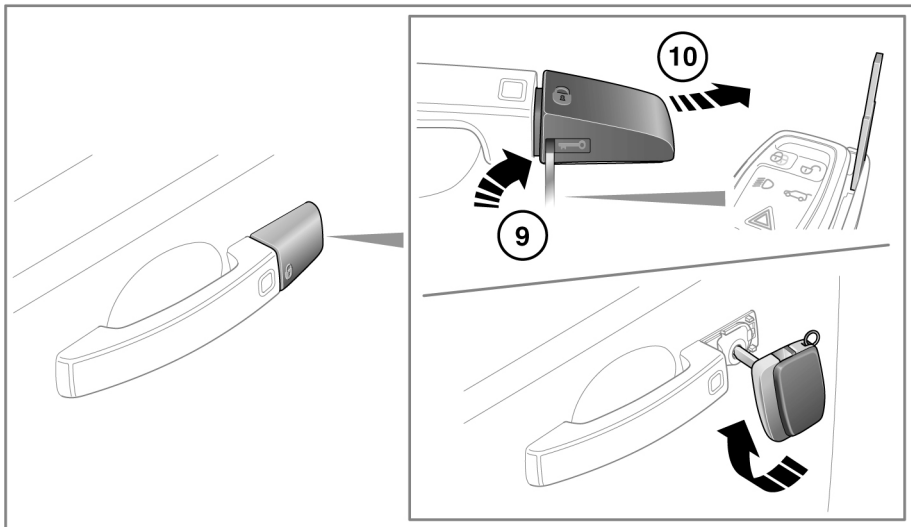

SL1041

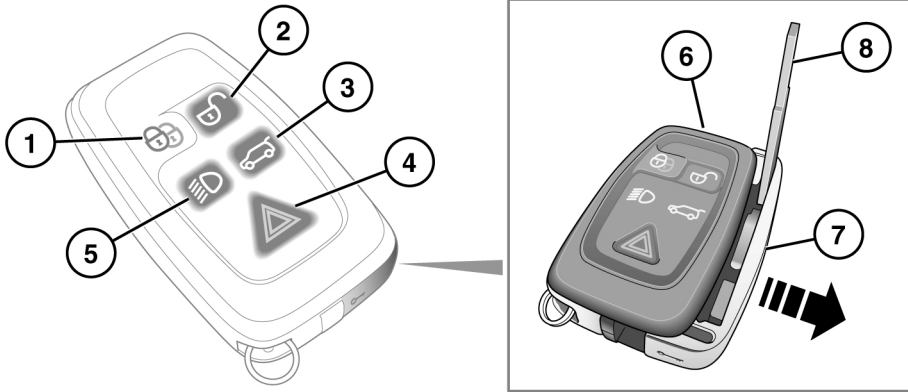

**To prevent accidental operation, never leave the Smart Key in the vehicle if children or animals are also left in the vehicle.**

**Note:** The operational range of the Smart Key will vary considerably depending on atmospheric conditions and interference from other transmitting devices.

**Note:** If any door or the tailgate is unlocked 10 times within a short period, the latch is disabled for approximately one minute.

The vehicle is supplied with 2 Smart Keys. The Smart Keys act as remote controls for the locking and alarm system, and allow the vehicle to be locked, unlocked and driven without the use of a conventional key. See **7, KEYLESS ENTRY, 11, KEYLESS LOCKING and 78, KEYLESS STARTING.**

## 1. Lock:

- Press once to single lock the vehicle. All doors and the tailgate will lock (but can still be unlocked from inside) and the perimeter alarm will arm. See **9, SINGLE LOCKING AND PERIMETER ALARM.**
- Press twice (within 3 seconds) to double lock the vehicle. All doors and the tailgate will lock (and cannot be unlocked from inside the vehicle) and both the perimeter alarm and interior space protection will be armed. See **9, DOUBLE LOCKING AND FULL ALARM.** See also **10, GLOBAL CLOSING.**

## 2. Unlock:

- Press briefly to unlock the vehicle and deactivate the alarm (see **6, SINGLE/MULTI-POINT ENTRY**). The hazard warning lamps will flash twice to indicate that the vehicle is unlocked and the alarm has been deactivated. The interior lamps will illuminate to assist entry to the vehicle. See also **6, GLOBAL OPENING.**

## 3. Tailgate release:

- Press briefly to release the tailgate. The vehicle security system will remain active while the tailgate is open, but intrusion and inclination sensing systems will be disabled.

On closing of the tailgate, the hazard warning lamps will flash after a few seconds to confirm the full alarm system has been reactivated (if previously armed). Also see **8, OPENING THE TAILGATE.**

## 4. Panic alarm:

- Press and hold for 3 seconds (or press 3 times within 3 seconds) to activate the horn and the hazard lamps.

**Note:** The horn and hazard lamps will switch off automatically after 2 minutes and 45 seconds.

- Once active for more than 5 seconds, the alarm can be cancelled by pressing the button and holding for 3 seconds (or pressing 3 times within 3 seconds).
- The emergency alarm will also be cancelled if a valid smart key is present when the START/STOP button is pressed.

## 5. Approach lighting:

- When approaching the vehicle during darkness, press to switch on the approach illumination. Press again to turn the approach lamps off.
- The approach illumination period set at the factory is 30 seconds. This delay period may be configured to provide illumination lasting between 0 and 180 seconds. See **58, VEHICLE INFORMATION AND SETTINGS MENU.**

## 6. Key blade release tab.

## 7. Slide out to expose key blade.

## 8. Key blade.

# Entering the vehicle

9. Insert the key blade into the slot at the base of the door lock cover and gently lever the key blade upwards.

Carefully twist the key blade, to lever the cover off the retaining clips.

10. Insert the key blade into the exposed lock to operate.

**To lock:** Ensure all doors are closed, then turn the key blade towards the front of the vehicle and release. This will lock the doors but will not arm the alarm.

**To unlock:** Turn the key blade towards the rear of the vehicle and release. If the security system is disarmed, all doors and the taildoor will be unlocked. If the security system is armed, only the driver's door will unlock.

If the vehicle is unlocked using the emergency key blade with the security system armed, the alarm will sound when the door is unlocked. To deactivate the alarm, press the unlock button on the Smart Key or press the engine START/STOP button with the Smart Key inside the vehicle.

**Note:** A replacement Smart Key can only be obtained from your Land Rover Dealer/ Authorised Repairer. The Dealer will require proof of ownership.

Notify your Dealer immediately if a Smart Key is lost or stolen.

**Note:** The fuel filler flap can only be opened when the vehicle is unlocked.

## AUTOMATIC RELOCKING

If a door or the tailgate are not opened within 1 minute of unlocking the vehicle, doors will lock again automatically.

## SINGLE/MULTI-POINT ENTRY

When you press the unlock button, your vehicle will unlock in one of two ways:

1. Single Point Entry: Unlocks the driver's door and fuel filler flap only. A second press is required to unlock the remaining doors and the tailgate.
2. Multi Point Entry: Unlocks all doors, fuel filler flap and the tailgate on the first press.

Single point entry can be disabled on individual Smart Keys by unlocking the vehicle then simultaneously pressing and holding the lock and unlock buttons for 3 seconds. The vehicle will lock and then unlock and the hazard warning lights will flash twice to confirm the change. You can now unlock all doors with a single press. Repeating the procedure will re-enable Single point entry.

This feature may also be set via the settings menu. See **58, VEHICLE INFORMATION AND SETTINGS MENU**.

## GLOBAL OPENING

Press and hold the unlock button for 3 seconds to unlock the vehicle and open all of the windows.

To cancel global opening, press any of the buttons on the smart key or operate the driver's window switch. To stop a particular window opening, operate the relevant window switch.

This feature can be enabled/disabled via the Vehicle settings menu (see **58, VEHICLE INFORMATION AND SETTINGS MENU**).

## KEYLESS ENTRY

Keyless entry allows the vehicle to be unlocked or disarmed, simply by operating any door handle. For keyless entry to activate, the Smart Key must be within 1.0m (3 feet) of the door handle when it is operated. When keyless entry operates, the alarm will be disarmed and the doors unlocked according to the current security setting (single or multipoint entry). The hazard warning lamps will flash twice as confirmation (in some markets an audible warning will sound twice).

**Note:** *The Smart Key needs only to be on the driver's person or in a non-metallic bag or briefcase. It does not need to be exposed or handled.*

**Note:** *If single point entry is the current security setting, and a door other than the driver's door is opened first, the vehicle will behave as if multi-point entry is active (i.e. all doors will unlock).*

## DISARMING THE ALARM

When the vehicle is unlocked using the remote control, the alarm is automatically disabled. The hazard lamps will flash twice to indicate that the alarm is disabled.

## DISARMING WHEN THE UNLOCK BUTTON FAILS TO WORK

If the unlock button fails to operate, the vehicle can still be unlocked and the alarm disabled. To unlock the vehicle:-

1. Unlock the drivers door using the key blade (see **4, UNLOCKING THE VEHICLE**, item **10**).
2. Position the Smart Key underneath the steering column (see **79, KEYLESS START BACKUP**).

**Note:** *When the driver's door is unlocked using the key, the alarm will sound until the Smart Key is positioned correctly.*

## SMART KEY CHECK

Should the last door be closed without a Smart Key present inside the vehicle, the message Smart Key Not Found Place As Shown will be displayed for 4 seconds in the vehicle message centre, to alert the driver to the absence of a Smart Key. See **79, KEYLESS START BACKUP**.

## DESELECTING VALET MODE

On entering the vehicle, enter your PIN into the display, and touch the **OK** soft key. See **11, VALET MODE**.

**Note:** *If the PIN number is lost or forgotten, the vehicle should be returned to your Dealer/ Authorised Repairer to have the PIN reset.*

## STEERING COLUMN LOCK



During vehicle recovery, the Smart Key must remain inside the vehicle, so that the steering column remains unlocked.

Your vehicle is fitted with an electronic steering column lock. The column unlocks when a Smart Key is detected inside the vehicle.

Any malfunction of the steering column lock will be indicated by the message **STEERING COLUMN LOCKED** being displayed in the message centre. If this occurs:

1. Lock and then unlock the vehicle using the Smart Key.
2. Try again to unlock the steering column lock, by turning the steering wheel gently to the left and right.
3. If the problem persists, seek qualified assistance immediately.

# Entering the vehicle

## OPENING THE TAILGATE

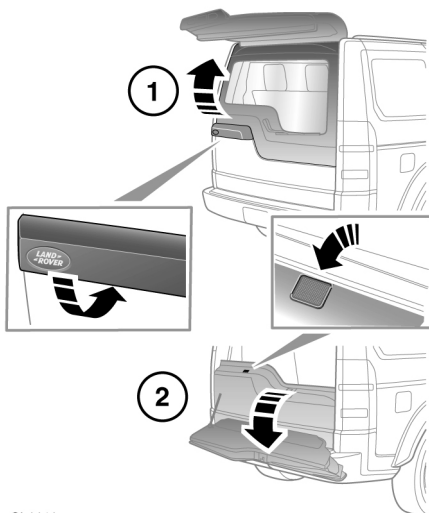

SL1141

**Upper tailgate:** Unlock the vehicle and press the touchpad (1) on the underside of the exterior handle. Pull the tailgate upwards to open.

**Lower tailgate:** With the upper tailgate open, press the touchpad on the lower tailgate waist moulding (2). Lower the tailgate to open.

## CHANGING THE SMART KEY BATTERY

When the battery needs renewing, there will be a significant decrease in the effective range and the message **SMART KEY BATTERY LOW** will be displayed in the message centre.

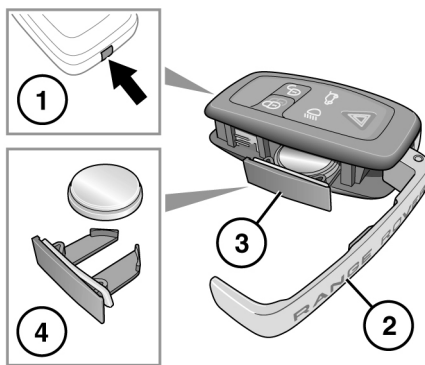

SL1190

To renew the battery:

1. Press and hold the release button.
2. Open the side cover.
3. Remove the battery drawer and remove the battery.
4. Fit a new CR2032 type battery (available from your Dealer/Authorised Repairer), with the positive (+) side upwards.

**Note:** Avoid touching the new battery, as moisture/oil from fingers can reduce battery life and corrode the contacts.

Refit the parts in reverse order, ensuring that they click securely into place.



**Battery disposal:** Used batteries must be disposed of correctly, as they contain harmful substances. Seek advice on disposal from your Dealer and/or your local authority.