

LIGHTING CONTROLS

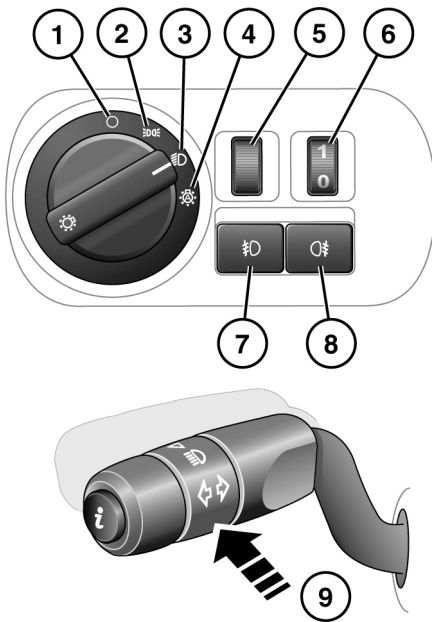

1. Headlamps/side lamps off.
2. Side lamps on.
3. Low beam headlamps on.
4. Autolamps on:
With the switch in this position and the ignition on, the side lamps, low beam headlamps and licence plate lamps illuminate automatically when the ambient light level is low. Auto high beam and Headlamp courtesy delay may also be activated (see below).
5. Dimmer control.
6. Halogen lamps height adjuster.

7. Rear fog lamps on/off:
When the rear fog lamps are on, the rear fog lamp warning lamp will illuminate.
8. Front fog lamps on/off:
When the front fog lamps are on, the front fog lamp warning lamp will illuminate.
9. High beam on/off/flash:
When low beam headlamps are switched on, push the indicator stalk to change to high beam (the high beam warning lamp will illuminate).

To flash the headlamps at anytime, briefly pull the indicator stalk and release it.

Note: Do not use high beam where it may dazzle other road users.

DAYLIGHT RUNNING LAMPS

With the main lighting control in the Off position (1), low beam headlamps, side lamps, tail, license plate lamps and, where fitted, side marker lamps, will switch on automatically under the following conditions:

- The ignition is on.
- The gear selector is out of park (automatic transmission).
- The parking brake is not applied (is released) - market dependent.



Unless required or prohibited by law, daylight running lamps can be disabled or enabled by your Dealer/Authorised

Repairer.

HEADLAMP COURTESY DELAY

This feature operates whenever the lamps master switch is left in the Auto position (4), and the ignition is turned off. The headlamps will remain illuminated for up to 240 seconds.

Note: The time delay may be changed via the Vehicle settings menu (see 58, **VEHICLE INFORMATION AND SETTINGS MENU**).

SL1059

AUTO HIGH BEAM

This feature automatically selects and deselects high beam, under specific conditions of road lighting and in the absence of other vehicle's lights. The system is only active when the ambient light drops below a predetermined level.

Note: It is not recommended that auto high beam is used while driving off road.

For auto high beam to become operational, the main lighting switch must be in the Auto position (4), with low beam headlamps selected.

The system will only activate when the vehicle speed exceeds 40 km/h (25 mph). The system will deactivate when vehicle speed drops below 24 km/h (15 mph).

To manually select high beam, move the stalk to the high beam position as normal. To return to Auto high beam, move the stalk back to the central position.

To manually override to low beam from high beam, pull the stalk to the flash position and auto high beam will be cancelled. To return to auto high beam, push the stalk to the high beam position and then return it to the central position.



A green warning lamp in the instrument pack illuminates when auto high beam is selected.

To turn off auto high beam, turn the main lighting control from Auto to headlamps on.

This feature can be disabled/enabled via the Vehicle settings menu (see 58, **VEHICLE INFORMATION AND SETTINGS MENU**).

Note: The following may affect the operation of auto high beam:-

- Highly reflective road signs.
- Vehicles with dim headlamps.
- Adverse weather conditions.
- Dirty sensor.
- Dirty, damaged, or misted windscreen.

Note: The system cannot be relied upon to activate or de-activate high beam in all possible circumstances. It remains the driver's responsibility to ensure correct use of the headlamps at all times.

Note: Ensure that the sensor on the back of the rear view mirror is not blocked or obstructed.

ADAPTIVE FRONT LIGHTING SYSTEM (AFS)

When cornering using low beam, AFS will adjust the headlamp beams to provide improved illumination in the direction of travel.

AFS is deactivated when:-

- Reverse gear is selected.
- The vehicle is stationary.
- Daylight running lamps are on.

If a system fault is detected the headlamps will attempt to move to the central position, and remain stationary. The AFS warning lamp will illuminate to indicate that a fault is present.



If the warning lamp illuminates, contact your Dealer/Authorised Repairer as soon as possible.

CORNERING LAMPS

When a direction indicator is activated, an additional lamp in the direction of turn is illuminated. This broadens the beam of the headlamps, improving visibility when turning.

ADJUSTING THE HEADLAMPS FOR DRIVING OVERSEAS

Note: The headlamps must be removed in order to change the beam pattern. See **187, HEADLAMP REMOVAL**.

Note: On LHD vehicles fitted with halogen headlamps, the lever is on the left hand side of the bulb aperture.

The tourist lever allows you to adjust the headlamps to the correct beam pattern for driving on the left or right hand side of the road.

When new, the lever will be set to the correct position for the country in which the vehicle is sold. To change the pattern for driving on the alternate side of the road, move the lever to the alternate position.

Note: When changing the beam pattern using the lever, ensure that you change the lever position on both headlamps.

Note: If the Auto high beam feature is enabled, you should also configure the system for the side of the road on which you are driving. See **58, VEHICLE INFORMATION AND SETTINGS MENU**.

XENON HEADLAMPS

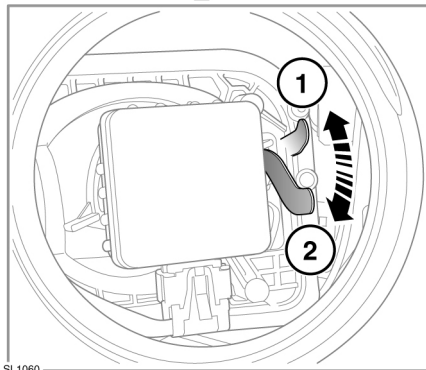
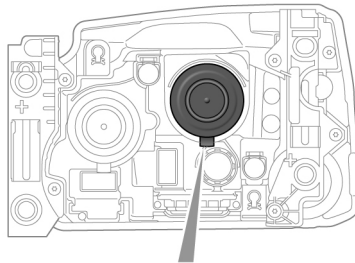

1. Lever in the correct position for the market where the vehicle was originally sold.
2. Lever in the correct position for when driving in countries where they drive on the opposite side of the road.

With the domed cap removed, move the lever to the appropriate position.

HALOGEN HEADLAMPS

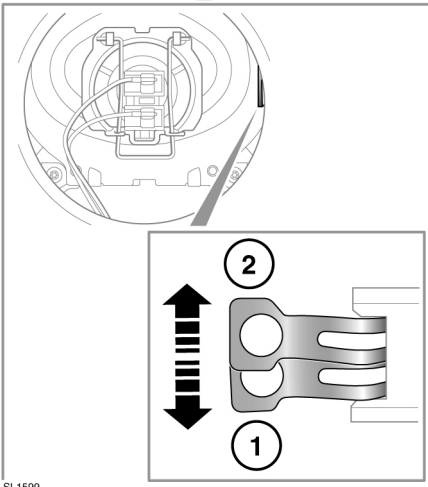
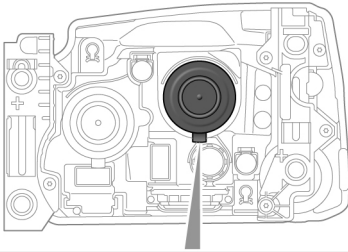

SL1599

1. Lever in the correct position for the market where the vehicle was originally sold.
2. Lever in the correct position for when driving in countries where they drive on the opposite side of the road.

With the domed cap removed, depress the lever and move to the appropriate position.

HEADLAMP LEVELLING (Halogen headlamps only)

Use the headlamp levelling control to account for vehicle loading changes.

Vehicle load	Switch position
Driver only	0
Driver and front seat passenger	0
Driver and passengers in all seats	Rotate down one position from 0.
Maximum gross vehicle weight	Rotate down two positions from 0.
Maximum rear axle load	Rotate down three positions from 0.

CONDENSATION

Misting of lamp lenses can occur under some atmospheric conditions. This will not affect the performance of the lamps and will clear during normal operation.