



FOLDING AND ERECTING THE REAR SEATS

-  Always ensure that objects carried within the vehicle are secured properly.
-  Never allow passengers to travel in the load space under any circumstances. All vehicle occupants should be seated correctly, and wear a seat belt at all times when the vehicle is in motion.

FOLDING THE SEATS - 5 SEAT VEHICLE

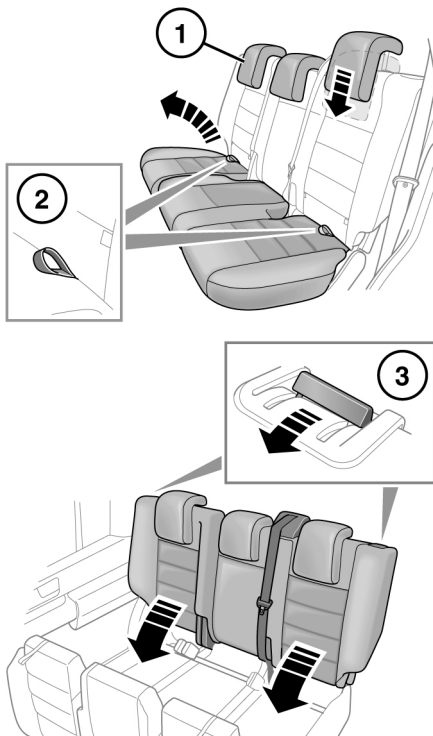

SL1047

The split fold rear seat can be folded completely to accommodate large loads, or partially to accommodate large loads and still retain seating for passengers.

To fold part or all of the seat:

1. Fully lower the head restraints.
2. Pull the strap on the required cushion(s), to raise to the vertical position.
3. Pull the seat backrest release lever(s), then lower the backrest(s) until locked into place.

Note: Some 5-seat models are fitted with the same type of seat as the 7-seat model.

ERECTING THE SEATS - 5 SEAT VEHICLE

-  Ensure that when the backrest is raised the locking mechanism is fully engaged. If the backrests are not fully locked in place, red markers will be visible around the backrest levers.

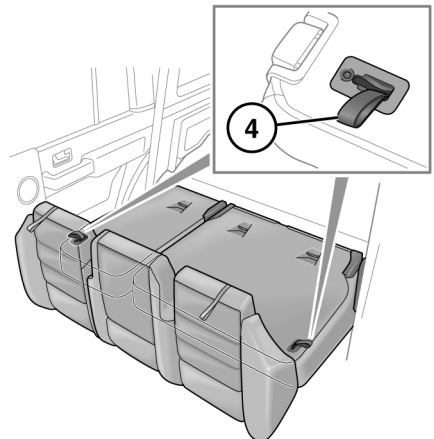

SL1546

Pull the strap (4) vertically to unlock the seats, then raise the seats by following the lowering process in reverse.

FOLDING THE SEATS- 7 SEAT VEHICLE

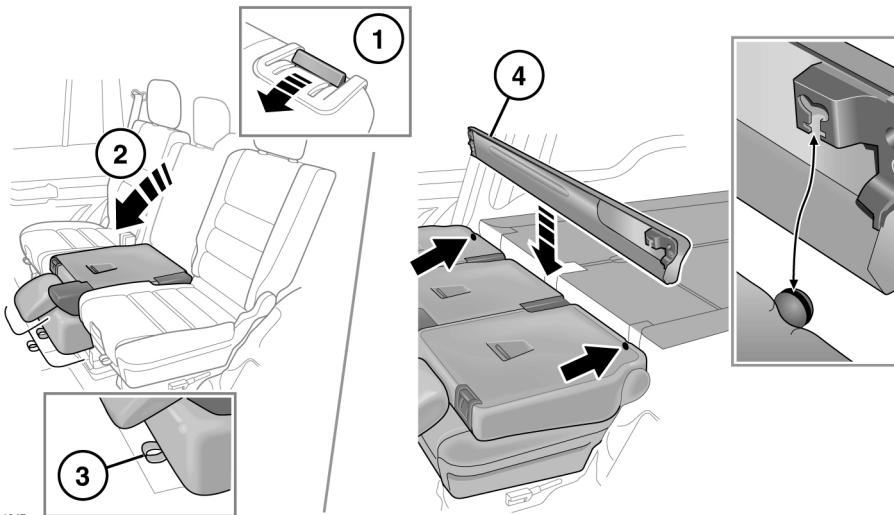

SL1047

One of the seats may be folded to form a table for the other two seats, or all three seats may be folded forward to extend the loadspace. A seat may also be folded to gain access to the 3rd row seats.

Note: The rear seats may not be folded if the front seats are in their furthest rearward position.

Note: The centre backrest must always be folded first.

1. Pull the backrest lever forwards.
2. Fold the backrest forwards into the table fold position.
3. Pull the strap at the front of the seat and press down to fold into the loadspace extension position.
4. The loadspace cover may be stowed as shown behind the folded seats.

ERECTING THE SEATS - 7 SEAT VEHICLE



The seat position should be checked and physically tested to ensure that the cushions and backrest are secure before driving. If the backrests are not fully locked in place, red markers will be visible around the backrest levers.



Do not attempt to raise the seats when the loadspace cover is stowed behind them. Damage to the loadspace cover will result.

Note: The centre backrest should always be raised last.

1. Pull the strap at the front of the cushion.
2. Grasp the top and bottom of the backrest, lift the seat and return it to the table fold position.
3. Push the release lever forward.

4. Pull the backrest up and push into place. When fully home the latching mechanism will click.

ACCESS POSITION - 7 SEAT VEHICLE



The vehicle must not be driven with the rear seats in the access position. Motion of the vehicle could cause the backrest to fall forwards suddenly, causing injury.

To access the third row of seats by this method, the headrest on the second row seat must first be lowered.

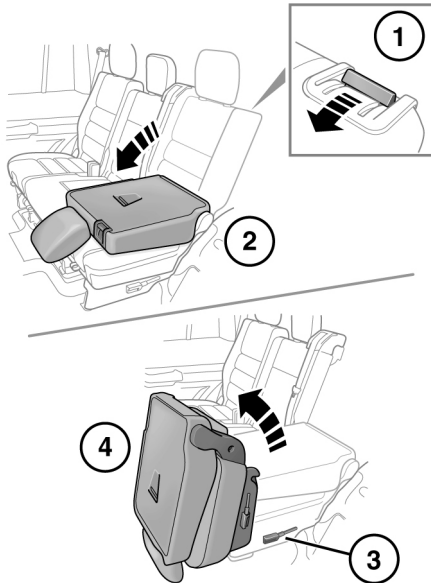

SL1228

1. Pull the backrest lever forwards.
2. Lower the backrest into the table fold position.
3. Pull the access lever on the side of the seat.
4. Tilt the seat forwards.

To return the seat to the upright position, lower the seat until the access lever re-engages, then pull the backrest lever and return the backrest to the upright position.

Note: A second row seat cannot be moved directly from the loadspace position to the access position. The backrest must first be returned to the table fold position.



When returning the seat from the access position, ensure nothing is trapped beneath the returning seat.



The seat position should be checked and physically tested to ensure that the cushions and backrest are secure before driving. If the backrests are not fully locked in place, red markers will be visible around the backrest levers.

THIRD ROW SEATS - 7 SEAT VEHICLE



Ensure nothing has been left under the third row seat, or in the footwell when folding down the seat, as this could cause damage to the item or the seat.



Beware of trapping fingers when raising and lowering the third row seat.



Do not attempt to raise the third row seats when the loadspace cover is stowed behind the second row seats. Damage to the loadspace cover or the seats may result.

It is possible to fold the third row seats flat.

FOLDING AND ERECTING THE THIRD ROW SEATS

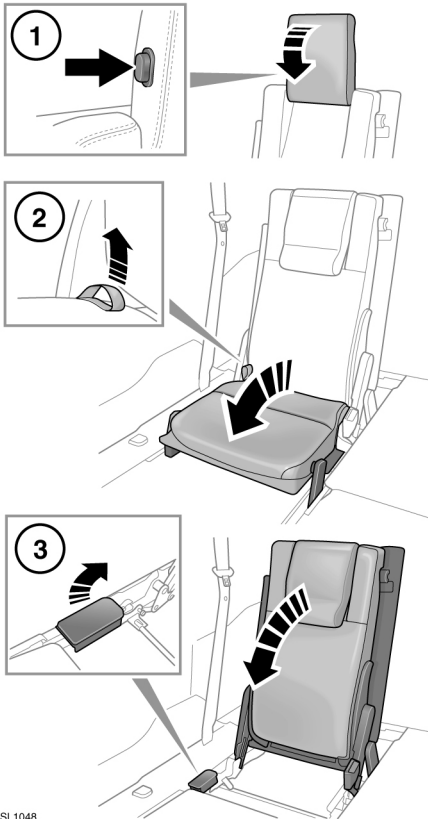

SL1048

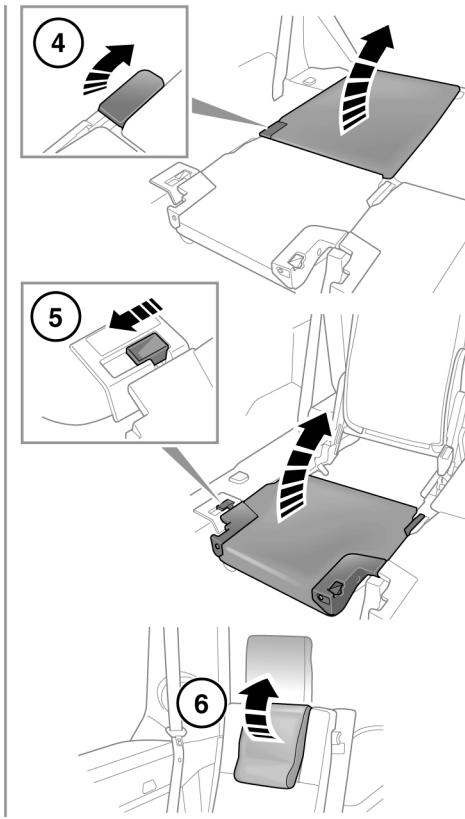

- 1. To fold:** Press the head restraint release button, and fold the head restraint fully downwards.
- 2.** Pull up the release strap (located at rear of cushion) to release the seat. This may require moderate force. Fold the cushion fully forwards until it latches into position.
- 3.** Pull up the backrest lever and fold the backrest fully forwards, until it latches into position in the loadspace floor.

- 4. To erect:** Pull backrest lever to release the backrest, and raise to the upright position. Ensure it is fully latched into position.
- 5.** Release the catch to raise cushion. Push into place, ensuring the cushion is latched to the backrest.
- 6.** Raise the head restraint until it latches into position.



The head restraint must always be raised when using the third row seats.

REAR HEAD RESTRAINTS



Adjust the head restraint so that the top of the head restraint is above the centre line of the head. An incorrectly adjusted head restraint increases the risk of death or serious injury in the event of a collision.



Do not drive or carry passengers with the head restraint removed from an occupied seat. The absence of a correctly adjusted head restraint increases the risk of neck injury in the event of a collision.



Always store a removed restraint securely.

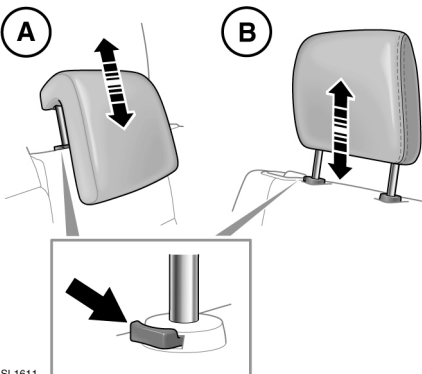

SL1611

A. 5-seat vehicles.

B. 7-seat vehicles.

To adjust:

- Press the locking button on the collar.
- Raise or lower the head restraint until the top of the restraint is level with the top of the passenger's head.

To remove:

- Press the locking button on the collar.
- Lift the head restraint out of the seat.

To refit:

- Ensure the head restraint is facing the correct direction.
- Insert the stems of the restraint into the sockets on the seatback.
- Push the restraint downwards until at least the first click.