

## PRINCIPLE OF OPERATION



**Do not rest your foot on the brake pedal whilst the vehicle is in motion.**



**Never allow the vehicle to coast (freewheel) with the engine turned off. The engine must be running to provide full braking assistance. The brakes will still function with the engine off, but far more pressure will be required to operate them.**



**If the red brake warning lamp illuminates, safely bring the vehicle to a stop, as quickly as possible and seek qualified assistance.**



**Never place non-approved floor matting or any other obstructions under the brake pedal. This restricts pedal travel and braking efficiency.**

Driving through heavy rain or water can have an adverse effect on braking efficiency. Under such circumstances, it is recommended that you lightly apply the brakes intermittently, to dry the brakes.

## ABS WARNING LAMP



The ABS warning lamp illuminates briefly when the ignition is turned on.

If this amber warning lamp illuminates when driving (accompanied by an associated warning message), drive with extra caution, avoid heavy braking where possible, and seek qualified assistance as soon as possible.

## STEEP SLOPES

If the vehicle is stationary on a steep, slippery slope, it may begin to slide even with the brakes applied. This is because without wheel rotation, the ABS cannot determine vehicle movement.

To counteract this, briefly release the brakes to allow some wheel rotation. Then re-apply the brakes to allow ABS to gain control.

## EMERGENCY BRAKE ASSIST (EBA)

If the driver rapidly applies the brakes, EBA automatically boosts the braking force to its maximum, in order to bring the vehicle to a halt as quickly as possible. If the driver applies the brakes slowly, but conditions mean that ABS operates on the front wheels, EBA will increase the braking force in order to apply ABS control to the rear wheels.

EBA stops operating as soon as the brake pedal is released.



The amber brake warning lamp illuminates briefly when the ignition is turned on.

A fault with the EBA system is indicated by the amber brake warning lamp illuminating and an associated warning message. Gently and safely stop the vehicle and seek qualified assistance.

## ELECTRONIC BRAKE DISTRIBUTION (EBD)

EBD controls the balance of braking forces supplied to the front and rear wheels, in order to maintain maximum braking efficiency.

If the vehicle has a light load (only the driver in the vehicle for example), EBD will reduce the braking force applied to the rear wheels. If the vehicle is heavily laden, EBD will allow greater braking force to the rear wheels.



The red brake warning lamp illuminates briefly when the ignition is turned on.

A fault with the EBD system is indicated by the red brake warning lamp illuminating and an associated warning message. Gently and safely stop the vehicle and seek qualified assistance.

## ELECTRIC PARKING BRAKE (EPB)

⚠ The parking brakes operates on the rear wheels. Therefore, secure parking of the vehicle is dependent on being on a hard and stable surface.

⚠ Do not rely on the parking brake to operate effectively, if the rear wheels have been immersed in mud or water.

**Note:** *If the vehicle is used in severe off-road conditions (e.g. wading, deep mud, etc.), additional maintenance and adjustment of the parking brake will be required. Consult your Land Rover Dealer/Authorised Repairer.*

## APPLYING THE EPB MANUALLY

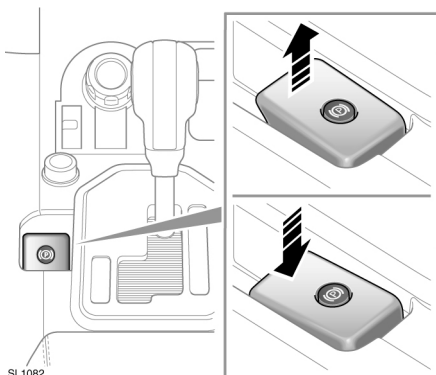

With the vehicle stationary, pull up the lever (arrowed) and release it.

**(P)** The parking brake warning lamp will illuminate. It is important to confirm that the lamp is continuously illuminated (not flashing), as this indicates the brake has been correctly applied. If the lever is operated when the vehicle speed is less than 3 km/h (2 mph) the vehicle will be brought to an abrupt stop. The stop lamps will not be illuminated.

## APPLYING THE EPB AUTOMATICALLY

EPB will be applied automatically if the ignition is switched off and the vehicle speed is below 3 km/h (2 mph). This will only occur on vehicles with automatic transmission if P (Park) is not selected.

To prevent automatic operation, when the vehicle is stationary, press and hold the EPB switch in the release position. Within 5 seconds, switch off the ignition and continue to hold the EPB switch for a further 2 seconds.

## DYNAMIC OPERATION

⚠ Driving the vehicle with the parking brake applied, or repeated use of the parking brake to slow the vehicle, may cause serious damage to the brake system.

In an emergency, with the vehicle travelling more than 3 km/h (2 mph), pulling on the EPB lever and holding gives a gradual reduction in the speed. The brake warning lamp will illuminate accompanied by a warning tone and **CAUTION PARKBRAKE APPLIED** appearing in the message centre. The stop lamps will illuminate.

## RELEASING THE EPB MANUALLY

With the ignition turned on, press the brake pedal and press down on the EPB lever. This will release the electronic parking brake.

## RELEASING THE EPB AUTOMATICALLY

### Manual transmission:

If the vehicle is stationary with the EPB applied, pressing the accelerator and releasing the clutch will release the EPB and allow the vehicle to move off.

Automatic release will operate in first, second and reverse in high range and first, second, third and reverse in low range.

To delay automatic release, hold the EPB lever in the applied position, and release at the desired point.

The parking brake system gradually reduces the system load to assist a smooth drive away. If the reduction in system load causes the vehicle to move after a valid gear is selected, full load will be automatically re-applied to the parking brake.

To override the load reducing feature of the EPB, manually apply the parking brake after selecting a gear.

In the event of a failure, the message **PARKBRAKE FAULT AUTO RELEASE UNAVAILABLE** will be displayed in the message centre.

### Automatic transmission:

If the vehicle is stationary with the EPB applied and the transmission in **D** or **R**, pressing the accelerator will release the EPB and allow the vehicle to move off.

**Note:** *Automatic release of the EPB is only possible when the driver's door is closed or the driver's seat belt is buckled.*

To delay automatic release, hold the EPB lever in the applied position, and release at the desired point.

The parking brake system gradually reduces the system load to assist a smooth drive away. If the reduction in system load causes the vehicle to move after a valid gear is selected, full load will be automatically re-applied to the parking brake.

To override the load reducing feature of the EPB, manually apply the parking brake after selecting a gear.

In the event of a failure, the message **PARKBRAKE AUTO RELEASE UNAVAILABLE** will be displayed in the message centre.

At the start of a journey, EPB release times may be extended when changing from **P** or **N**. This is to allow for increased gear engagement times.

## EPB WARNING LAMPS

If the system detects a fault with the EPB, the amber brake warning lamp will illuminate accompanied by a message on the message centre.

If the system detects a fault while EPB is operating, the red parking brake warning lamp will flash and the message **PARKBRAKE FAULT** will appear in the message centre.

**Note:** *The red brake warning lamp will continue to be illuminated for at least ten seconds after the ignition has been turned off.*