

# Entering the vehicle

## UNLOCKING THE VEHICLE

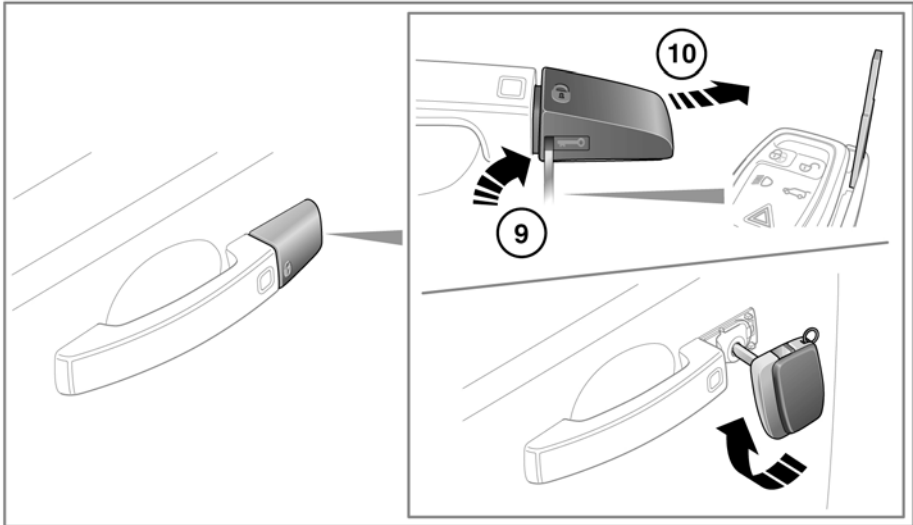

SL1041

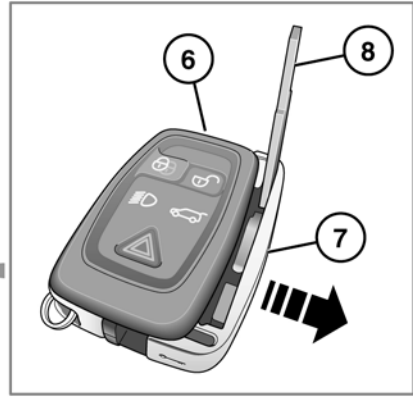
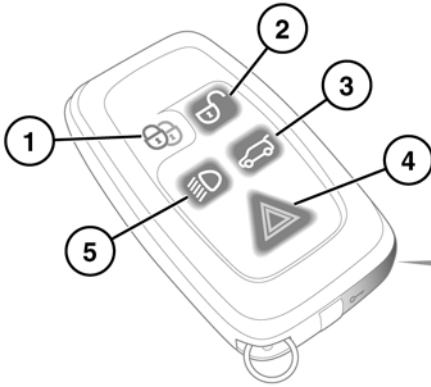

**WARNING:** To prevent accidental operation which may result in an injury, never leave the Smart Key in the vehicle if children or animals are also left in the vehicle.

**Note:** The operational range of the Smart Key will vary considerably depending on atmospheric conditions and interference from other transmitting devices.

**Note:** If any door or the taildoor is unlocked 10 times within a short period, the latch is disabled for approximately one minute.

The vehicle is supplied with 2 Smart Keys. The Smart Keys act as remote controls for the locking and alarm system, and allow the vehicle to be locked, unlocked and driven without the use of a conventional key. See **8, KEYLESS ENTRY, 12, KEYLESS LOCKING** and **70, KEYLESS STARTING**.

1. Lock:  
Press once to lock the vehicle. All doors and the taildoor will lock (but can still be unlocked from inside) and the perimeter alarm will arm. See **11, LOCKING AND ARMING THE ALARM**.
2. Unlock:  
Press briefly to unlock the vehicle and deactivate the alarm (see **8, SINGLE/MULTI-POINT ENTRY**). The hazard warning lamps will flash twice to indicate that the vehicle is unlocked and the alarm has been deactivated. The interior lamps will illuminate to assist entry to the vehicle.  
See also **8, GLOBAL OPENING**.

3. Taildoor release:  
Press briefly to release the taildoor. The vehicle security system will remain active while the taildoor is open, but intrusion and inclination sensing systems will be disabled.

On closing of the taildoor, the hazard warning lamps will flash after a few seconds to confirm the full alarm system has been reactivated (if previously armed). Also see **9, OPENING THE TAILDOOR/TAILGLASS**.



The operation of this button can be configured by a Land Rover Retailer/authorized Repairer, to open the tailglass instead of the taildoor.

4. Panic alarm:
  - Press and hold for 3 seconds (or press 3 times within 3 seconds) to activate the horn and the hazard lamps.  
**Note:** *The horn and hazard lamps will switch off automatically after 2 minutes and 45 seconds.*
  - Once active for more than 5 seconds, the alarm can be cancelled by pressing the button and holding for 3 seconds (or pressing 3 times within 3 seconds).
  - The emergency alarm will also be cancelled if a valid smart key is present when the START/STOP button is pressed.
5. Approach lighting:
  - When approaching the vehicle during darkness, press to switch on the approach illumination. Press again to turn the approach lamps off.
  - The approach illumination period set at the factory is 30 seconds. This delay period may be configured to provide illumination lasting between 0 and 180 seconds. See **58, VEHICLE INFORMATION AND SETTINGS MENU**.
6. Key blade release button.
7. Slide out to expose key blade.
8. Key blade.
9. Insert the key blade into the slot at the base of the door lock cover and gently lever the key blade upwards.  
Carefully twist the key blade, to lever the cover off the retaining clips.
10. Insert the key blade into the exposed lock to operate.

# Entering the vehicle

**To lock:** Ensure all doors are closed, then turn the key blade towards the front of the vehicle and release. This will lock the doors but will not arm the alarm.

**To unlock:** Turn the key blade towards the rear of the vehicle and release. If the security system is disarmed, all doors and the taildoor will be unlocked. If the security system is armed, only the driver's door will unlock.

If the vehicle is unlocked using the emergency key blade with the security system armed, the alarm will sound when the door is unlocked. To deactivate the alarm, press the unlock button on the Smart Key or press the engine START/STOP button with the Smart Key inside the vehicle.

**Note:** A replacement Smart Key can only be obtained from your Land Rover Retailer/Authorized Repairer. The Retailer/Authorized Repairer will require proof of ownership.

Notify your Land Rover Retailer/Authorized Repairer immediately if a Smart Key is lost or stolen.

**Note:** The fuel filler flap can only be opened when the vehicle is unlocked.

## AUTOMATIC RELOCKING

If a door or the taildoor are not opened within 1 minute of unlocking the vehicle, doors will lock again automatically.

## SINGLE/MULTI-POINT ENTRY

When you press the unlock button, your vehicle will unlock in one of two ways:

1. Single Point Entry: Unlocks the driver's door only. A second press is required to unlock the remaining doors and the taildoor.
2. Multi Point Entry: Unlocks all doors and the taildoor on the first press.

Single point entry can be disabled on individual Smart Keys by unlocking the vehicle then simultaneously pressing and holding the lock and unlock buttons for 3 seconds. The vehicle will lock and then unlock and the hazard warning lights will flash twice to confirm the change. You can now unlock all doors with a single press. Repeating the procedure will re-enable Single point entry.

This feature may also be set via the settings menu. See **58, VEHICLE INFORMATION AND SETTINGS MENU**.

## GLOBAL OPENING

Press and hold the unlock button for 3 seconds to unlock the vehicle and open all of the windows.

To cancel global opening, press any of the buttons on the smart key or operate the driver's window switch. To stop a particular window opening, operate the relevant window switch.

This feature can be enabled/disabled via the Vehicle settings menu. See **52, VEHICLE INFORMATION AND SETTINGS MENU**.

## KEYLESS ENTRY

Keyless entry allows the vehicle to be unlocked or disarmed, simply by operating any door handle. For keyless entry to activate, the Smart Key must be within 3 feet (1.0 m) of the door handle when it is operated. When keyless entry operates, the alarm will be disarmed and the doors unlocked according to the current security setting (single or multipoint entry). The hazard warning lamps will flash twice as confirmation (in some markets an audible warning will sound twice).

**Note:** The Smart Key needs only to be on the driver's person or in a non-metallic bag or briefcase. It does not need to be exposed or handled.

**Note:** If single point entry is the current security setting, and a door other than the driver's door is opened first, the vehicle will behave as if multi-point entry is active (i.e. all doors will unlock).

## DISARMING WHEN THE UNLOCK BUTTON FAILS TO WORK

If the unlock button fails to operate, the vehicle can still be unlocked and the alarm disabled. To unlock the vehicle:-

1. Unlock the drivers door using the key blade (see 6, **UNLOCKING THE VEHICLE**, item 10).
2. Position the Smart Key underneath the steering column (see 71, **KEYLESS START BACKUP**).

**Note:** When the driver's door is unlocked using the key, the alarm will sound until the Smart Key is positioned correctly.

## SMART KEY CHECK

Should the last door be closed without a Smart Key present inside the vehicle, the message Smart Key Not Found Place As Shown will be displayed for 4 seconds in the vehicle message center, to alert the driver to the absence of a Smart Key. See 71, **KEYLESS START BACKUP**.

## SMART KEY SYSTEM TRANSMITTERS



**WARNING:** Any person fitted with an implanted medical device is kept at a distance of at least 8.7 inches (22cm) away from any transmitter mounted in the vehicle. This is to avoid any possibility of interference between the system and the device. See 195, **SMART KEY SYSTEM TRANSMITTERS**.

## OPENING THE TAILDOOR/TAILGLASS

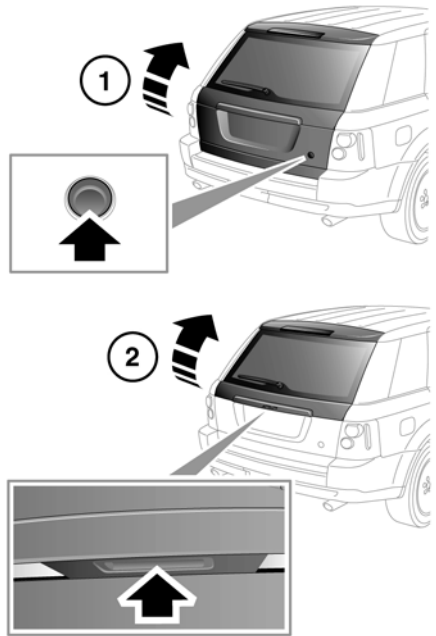

SL1142

1. **Taildoor:** With the vehicle unlocked, press the taildoor release button.

**Note:** The taildoor incorporates a power closure feature, so there is no need to slam it closed.

2. **Tailglass:** With the vehicle unlocked press the touch pad on the underside of the handle and pull to open.

**Note:** It is not possible to open the tailglass when the taildoor is open and vice versa. Close one open aperture, before attempting to open the other.

## CHANGING THE SMART KEY BATTERY

When the battery needs renewing, there will be a significant decrease in the effective range and the message SMART KEY BATTERY LOW will be displayed in the message center.

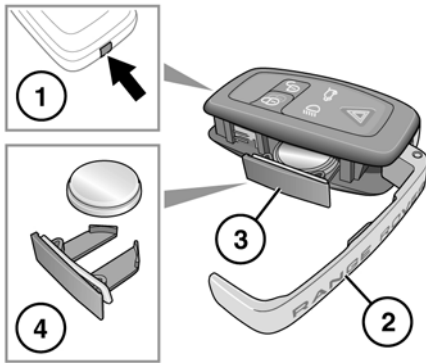

SL1190

To renew the battery:

1. Press and hold the release button.
2. Open the side cover.
3. Remove the battery drawer and remove the battery.
4. Fit a new CR2032 type battery (available from your Land Rover Retailer/Authorized Repairer), with the positive (+) side upwards.

**Note:** Avoid touching the new battery, as moisture/oil from fingers can reduce battery life and corrode the contacts.

Refit the parts in reverse order, ensuring that they click securely into place.



**Battery disposal:** Used batteries must be disposed of correctly, as they contain harmful substances. Seek advice on disposal from your

Land Rover Retailer/Authorized Repairer and/or your local authority.