

DISABILITY MODIFICATIONS



WARNING: Occupants with disabilities that may require the vehicle to be modified must contact a Land Rover Retailer/Authorized Repairer before any modifications are made.

(USA only) If you are considering modifying your vehicle in any way to accommodate a disability, for example by altering or adapting the driver's or passenger's seat(s) or air bag system, please contact Land Rover Limited at:

Land Rover Limited
Customer Relations Center
555 MacArthur Blvd
Mahwah
New Jersey 07430-2327
1-800-637-6837, option #9.

CALIFORNIA PROPOSITION 65

WARNING



WARNING: Engine exhaust, some of its constituents, and certain vehicle components contain or emit chemicals known to the State of California to cause cancer and birth defects or other reproductive harm. In addition, certain fluids contained in vehicles and certain products of component wear contain or emit chemicals known to the State of California to cause cancer and birth defects or other reproductive harm.



WARNING: Battery posts, terminals and related accessories contain lead and lead compounds. Wash hands after handling.



WARNING: Certain components of this vehicle such as air bag modules and seat belt pretensioners may contain Perchlorate Material - Special handling may apply for service or vehicle end of life disposal. See www.dtsc.ca.gov/hazardous_waste/perchlorate.

PARTS AND ACCESSORIES



WARNING: Do not fit non-approved parts and accessories or carry out non-approved alterations or conversions.

AIR BAG SYSTEM



WARNING: The components that make up the air bag system are sensitive to electrical or physical interference, either of which could easily damage the system and cause inadvertent operation or a malfunction of the air bag module.

To prevent malfunction of the air bag system always consult your Land Rover Retailer/Authorized Repairer before fitting any of the following:

- Electronic equipment such as a mobile phone, two-way radio or audio system.
- Accessories attached to the front of the vehicle.
- Any modification to the front of the vehicle.
- Any modification involving the removal or repair of any wiring or component in the vicinity of any of the air bag system components, including the steering wheel, steering column, instrument or facia panels.
- Any modification to the facia panels or steering wheel.

SERVICE INTERVALS

An upcoming service interval will be notified to the driver via the Driver Information Module, as either a distance or time left until service is due. Once the distance or time are exceeded, the display will show a negative value (-) to indicate that a service is overdue.

One or both types of service interval (distance and time) may be displayed.

PASSPORT TO SERVICE

Ensure your service provider signs and stamps the book after each service and inspection.

OWNER MAINTENANCE



CAUTION: Any significant or sudden drop in fluid levels, or uneven tire wear, should be reported to a qualified technician without delay.

In addition to the routine maintenance, a number of simple checks must be carried out more frequently.

DAILY CHECKS

- Operation of lamps, horn, direction indicators, wipers, washers and warning lamps.
- Operation of seat belts and brakes.
- Look for fluid deposits underneath the vehicle that might indicate a leak.

WEEKLY CHECKS

- Engine oil level.
- Engine coolant check.
- Brake fluid level.
- Power steering fluid level.
- Windshield washer fluid level.
- Tire pressures and condition.
- Operate air conditioning.

Note: The engine oil level should be checked more frequently if the vehicle is driven for prolonged periods at high speeds.

DRIVING IN ARDUOUS CONDITIONS

When a vehicle is operated in extremely arduous conditions, more frequent attention must be paid to servicing requirements.

Arduous driving conditions include:

- Driving in dusty and/or sandy conditions.
- Driving on rough and/or muddy roads and/or wading.
- Driving in extremely hot conditions.
- Towing a trailer or driving in mountainous conditions.

Contact a Land Rover Retailer/Authorized Repairer for advice.

EMISSION CONTROL

Your vehicle is fitted with various items of emission and evaporative control equipment, designed to meet specific territorial requirements. You should be aware that unauthorized replacement, modification or tampering with this equipment by an owner or repair shop, may be unlawful and subject to legal penalties.

In addition, engine settings must not be tampered with. These have been established to ensure that your vehicle complies with stringent exhaust emission regulations. Incorrect engine settings may adversely affect exhaust emissions, engine performance and fuel consumption. They may also cause high temperatures, which will result in damage to the catalytic converter and the vehicle.

ROAD TESTING DYNAMOMETERS (ROLLING ROADS)

It is essential that any dynamometer testing is carried out only by a qualified person, familiar with the dynamometer testing and safety procedures practised by Land Rover Retailer/ Authorized Repairers.

SAFETY IN THE GARAGE



WARNING: If the vehicle has been driven recently, do not touch the engine, exhaust and cooling system components until the engine has cooled.



WARNING: Never leave the engine running in an unventilated area - exhaust gases are poisonous and extremely dangerous.



WARNING: Do not work beneath the vehicle with the wheel changing jack as the only means of support.



WARNING: Keep your hands and clothing away from drive belts, pulleys and fans. Some fans may continue to operate after the engine has stopped.



WARNING: Remove metal wrist bands and jewellery, before working in the engine compartment.



WARNING: Do not touch electrical leads or components while the engine is running, or with the ignition turned on.



WARNING: Do not allow tools or metal parts of the vehicle to make contact with the battery leads or terminals.

FUEL SYSTEM



WARNING: Under no circumstances should any part of the fuel system be dismantled or replaced by anyone other than a suitably qualified vehicle technician.



WARNING: Ensure sparks and naked lights are kept away from the engine compartment.



WARNING: Wear protective clothing, including, where practicable, gloves made from an impervious material.

POISONOUS FLUIDS

Fluids used in motor vehicles are poisonous and should not be consumed or brought into contact with open wounds.

For your own safety, always read and obey all instructions printed on labels and containers.

USED ENGINE OIL

Prolonged contact with engine oil may cause serious skin disorders, including dermatitis and cancer of the skin. Always wash thoroughly after contact.



It is illegal to pollute drains, water courses or soil. Use authorized waste disposal sites to dispose of used oil and toxic chemicals.

OPENING THE HOOD

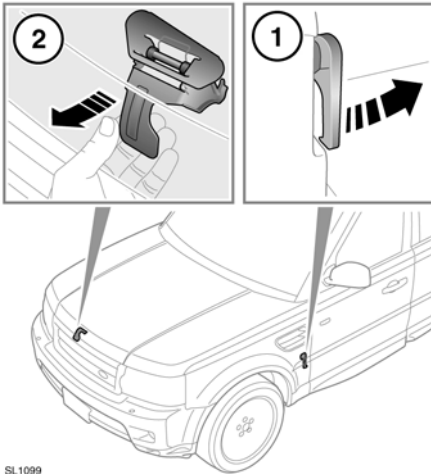

SL1099

1. Pull the hood release lever, located in the left-hand front footwell.
2. Lift the hood safety catch lever, located below the center point of the hood, then raise the hood.

CLOSING THE HOOD

WARNING: Do not drive with the hood retained by the safety catch alone.

1. Lower the hood until the safety catch engages. Using both hands, press the hood down until the catches click.
2. Check that both catches are engaged, by trying to lift the front edge of the hood.

ENGINE COMPARTMENT OVERVIEW

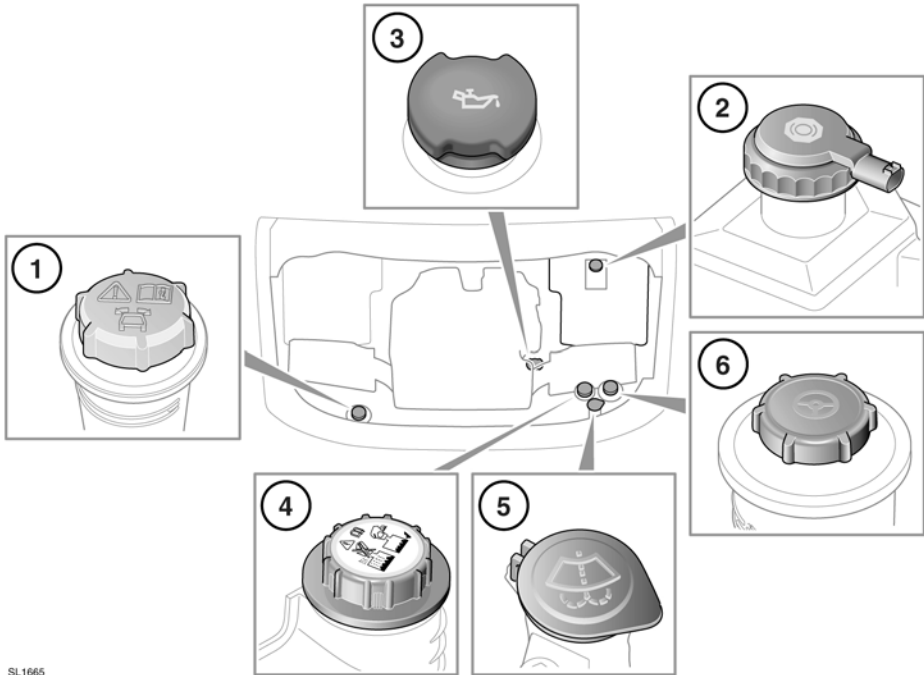

SL1665

1. Dynamic response fluid reservoir cap.
2. Brake fluid reservoir cap.
3. Engine oil filler cap.
4. Engine coolant filler cap.
5. Windshield washer fluid filler cap.
6. Power steering fluid filler cap.



WARNING: While working in the engine compartment, always observe the safety precautions. See 168, SAFETY IN THE GARAGE.



WARNING: Do not drive if there is a possibility that leaked fluid will come into contact with a hot surface, such as the exhaust.

UNDERHOOD COVERS - REMOVAL

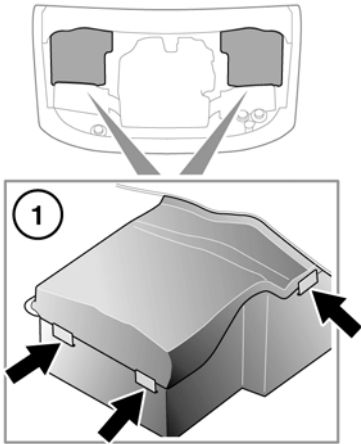

SL1102

1. Press the tabs to release the cover from the casing.

Note: Releasing the inboard tab on the front edge of the cover first will make it easier to release the remaining tabs.

2. Lift the front edge of the cover and slide forwards to remove.

UNDERHOOD COVERS - REFITTING

- ⚠ CAUTION: Before refitting the underhood covers, ensure that no pipes, cables or other items, have been trapped between the cover and casing.

1. Slide the rear edge of the cover under the rubber trim fitted to the scuttle panel.
2. Make sure the front edge of the cover is flush to the casing, and then press down until the cover clicks into place.

BLOCKED WASHER JETS



WARNING: Do not operate the washer jets during unblocking or adjustment. Windshield washer fluid may cause irritation to the eyes and skin. Always read and observe the washer fluid manufacturer's instructions.

If a washer jet becomes blocked, use a thin strand of wire to unblock the jet by inserting the wire into the jet. Ensure that the wire is completely removed after unblocking. The washer jet position may also be adjusted by inserting the point of a needle into the jet and gently repositioning it.

CHANGING A BULB



CAUTION: Before attempting to replace a bulb, ensure that both the affected lamp and the vehicle's ignition are turned off. If the circuit remains live, a short circuit can occur which may damage the vehicle's electrical system.



CAUTION: Always replace bulbs with the correct type and specification. If you are in any doubt contact your Land Rover Retailer/Authorized Repairer for advice.

Note: In certain territories it is a legal requirement to carry spare bulbs. A replacement bulb kit is available as an approved accessory from your Land Rover Retailer/Authorized Repairer.

HEADLAMP REMOVAL

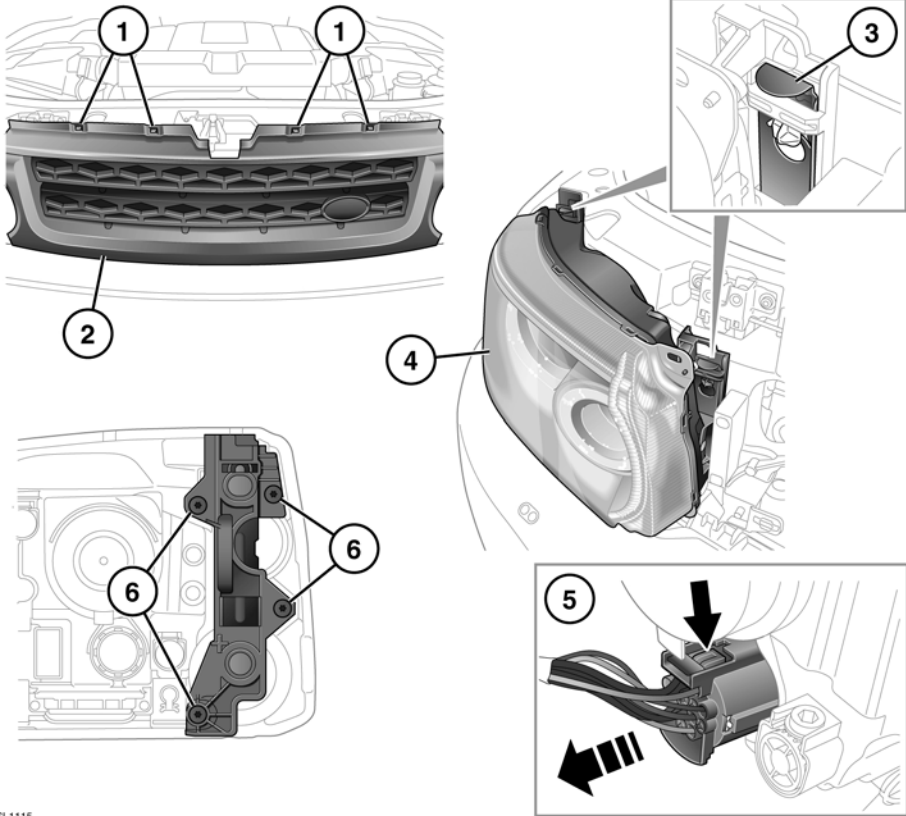

SL1115



WARNING: Do not attempt to change any bulb with the lighting switch on. If the lighting has just been switched off, give the bulbs time to cool down. Handling them in a hot condition may cause personal injury.



CAUTION: Do not place the removed lamp unit face down on hard or abrasive surfaces. Doing so may scratch the surface of the lens.

1. Press down on the four upper clips, and gently pulling the grill forwards.
2. Lift the grille clear of the vehicle and place where it will not be damaged.
3. Carefully lever up the locking tabs securing the rear of the headlamp. Hold the headlamp in position while doing so.

4. Holding the front of the lamp, lift forwards and clear of the body.

Note: *The locking tabs (3) can be levered too far up, preventing the headlamp being released. If this happens ease the tabs down until the headlamp can be moved forward.*

5. Disconnect the electrical connector from the back of the unit and remove the unit from the vehicle.

Note: *Place face down on a flat surface covered in a soft material to prevent damage to the units lenses*

6. To access the direction indicator, static bending lamp and side lamp, the headlamp unit locking slide assembly must be completely removed from the unit.

To remove the slide assembly, remove the four screws (arrowed). When refitting the slide, do not overtighten the screws.

Note: *Refitting the headlamp unit is the reverse of removal.*

XENON LAMPS



WARNING: Replacement or maintenance of Xenon lamps should only be carried out by suitably qualified personnel.



WARNING: High voltage is required to ignite the gas and metal vapour which are used to power Xenon lamps. Contact with this voltage can cause serious injury.



WARNING: Xenon lamp units operate at a very high temperature. Ensure that the lamp units have cooled before attempting to touch them.



WARNING: Xenon lamp units contain Mercury which is highly toxic and can be extremely harmful.



Seek advice about the correct disposal of Xenon lamp units from a Land Rover Retailer/Authorized Repairer, or your local authority.

XENON HEADLAMP BULB

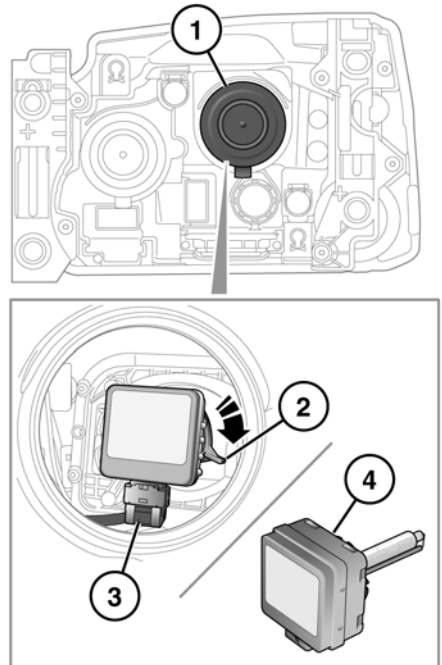

SL1116

1. Twist and lift off the domed cap.
2. Rotate the collar securing the bulb to the lamp and release the bulb.
3. Pull off the electrical connector.
4. Remove bulb unit.
5. Insert the new bulb unit and reverse the above procedure. Ensure that the lugs on the cap are in contact with the bulb base.

INDICATOR BULB

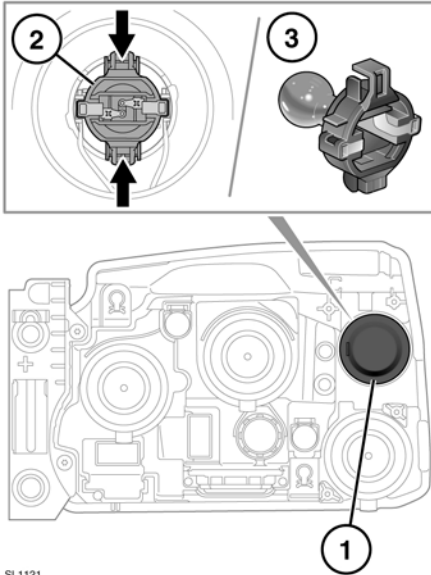

SL1121

1. Twist and lift off the cap.
2. Press the catches and pull the bulb holder from the unit.
3. Push and twist to remove the bulb.

FRONT FOG LAMP BULB

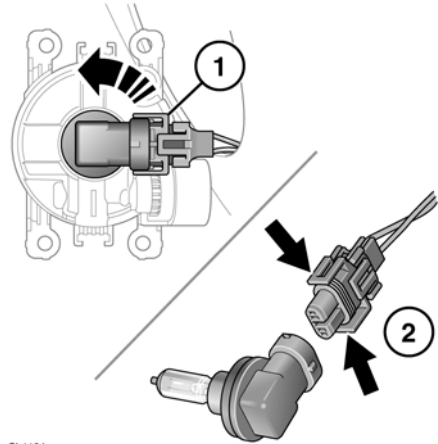

SL1124

1. Rotate the bulb holder (counter-clockwise) and remove from the lamp unit.
2. Press the two clips together, and remove the electrical connector.

REMOVING A REAR LAMP

To change any of the rear bulbs, it is necessary to completely remove the lamp unit from the vehicle.

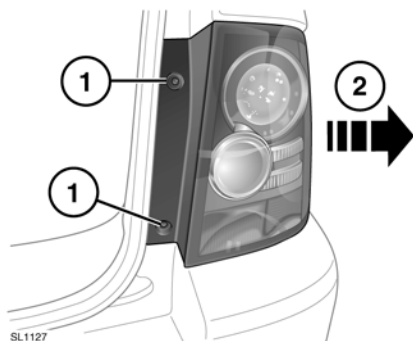

1. With the taildoor open, remove the two screws from the inner edge of the unit.
2. Pull the unit carefully away from the vehicle.
3. Disconnect the electrical connector and remove the unit from the vehicle. Place face down on a flat surface covered in soft material to prevent damage.

CHANGING REAR LAMP BULBS

Note: The direction indicator lamp, stop lamp, and tail lamp are LED units, and cannot be serviced.

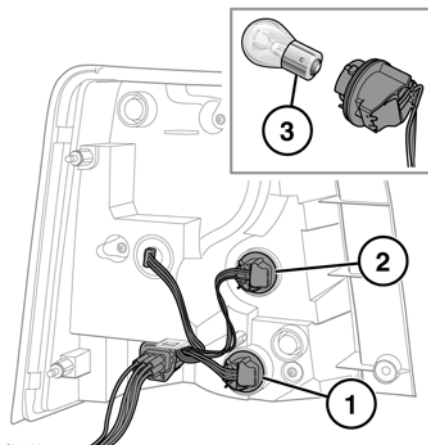

1. Rear fog lamp.
2. Reversing lamp
3. Twist the relevant bulb unit and pull to access the bulb. Push, twist and pull to remove the bulb.

SIDE REPEATER LAMP BULB

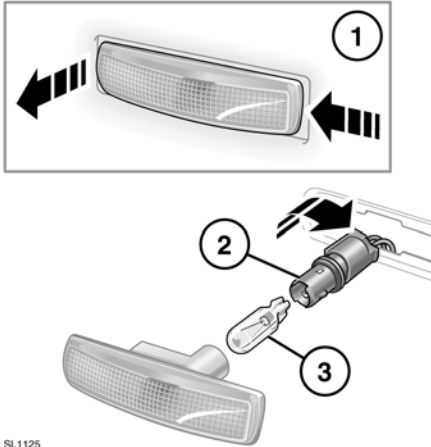

Follow the steps illustrated. Insert a new bulb and refit the components.

LICENCE PLATE LAMP BULB

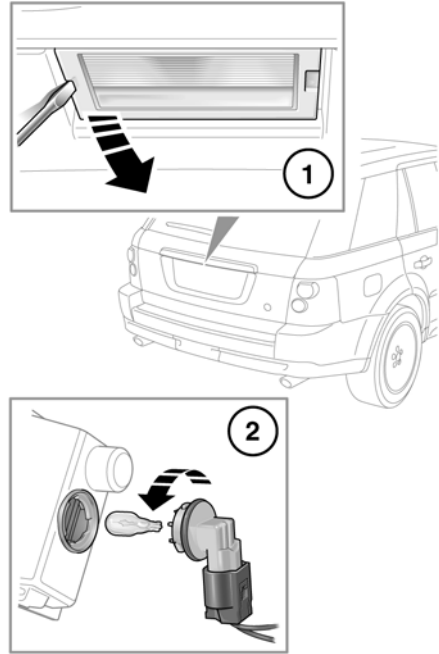

1. Using a small flat-bladed screwdriver, carefully prize the lamp from the taildoor.
2. Twist the bulb holder counter-clockwise to unlock then pull to remove. Pull out the bulb to remove.

INTERIOR LAMPS - BULB CHANGING

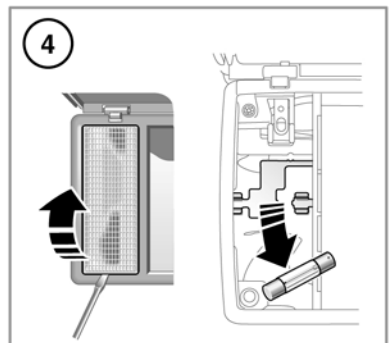
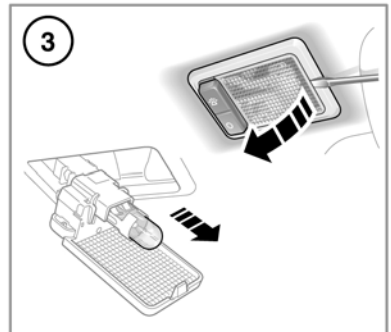
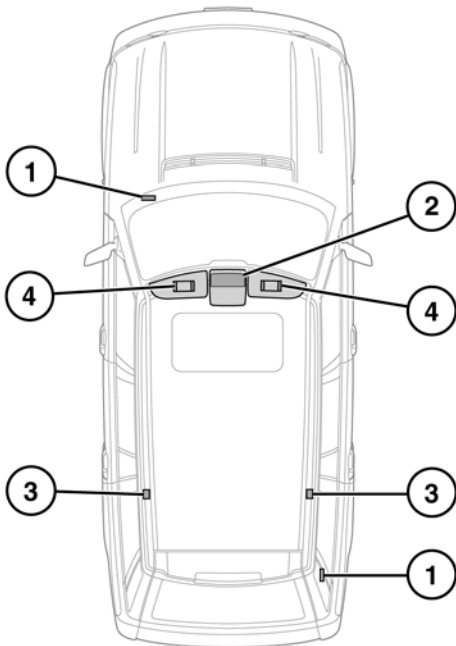
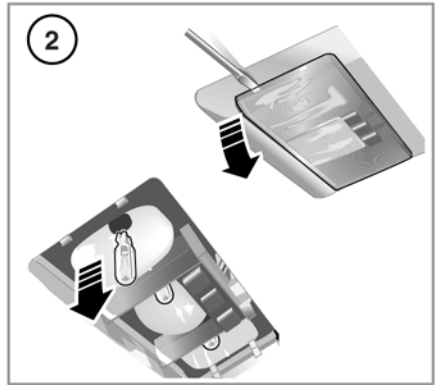
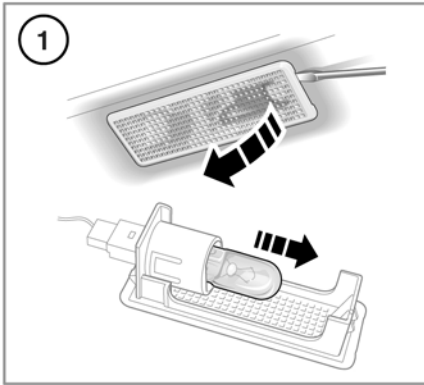

SL1150

Follow the steps illustrated. Insert a new bulb and refit the components.

1. Footwell and puddle lamps.
2. Courtesy lamp and map lamps.
3. Rear courtesy lamps.
4. Vanity mirror lamps.

WINDOW RESET

The windows will need to be reset if the battery is disconnected, becomes discharged or power supply is interrupted.

Reset as follows:

1. Close the window fully.
2. Release the switch, then lift it to the close position and hold for 1 second.
3. Repeat the procedure on each window.

SUNROOF RESET

If the battery is disconnected or the power supply is interrupted while the sunroof is partially open, it will need to be recalibrated.

Once the battery is reconnected or the power supply is restored, recalibrate the sunroof as follows:

1. Switch the ignition on.
2. With the sunroof closed, press and release the front of the switch. The sunroof will move to the tilted position.
3. Press the front of the sunroof switch and hold for 20 seconds.
4. After 20 seconds, the sunroof will begin to move. Keep the front of the switch pressed until the fully open/close cycle has completed.
5. Once the sunroof has stopped moving, release the switch.

The sunroof can now be operated as normal.

SERVICE DATA RECORDING

Service data recorders in your vehicle are capable of collecting and storing diagnostic information about your vehicle. This potentially includes information about the performance or status of various systems and modules in the vehicle such as engine, throttle, steering or brakes.

In order to properly diagnose and service your vehicle, Land Rover and service and repair facilities may access vehicle diagnostic information through a direct connection to your vehicle.

PARTS AND ACCESSORIES



WARNING: The fitting of non-approved parts and accessories, or the carrying out of non-approved alterations or conversions, may be dangerous and could affect the safety of the vehicle and occupants and also invalidate the terms and conditions of the vehicle warranty.



WARNING: Land Rover will not accept any liability for death, personal injury or damage to property which may occur as a result of fitment of non-approved accessories or the carrying out of non-approved conversions to Land Rover vehicles.

CLEANING THE EXTERIOR

- !** CAUTION: Some high pressure cleaning systems are sufficiently powerful to penetrate door/window seals and damage trim and door locks. Never aim the water jet directly at the engine air intake, heater air intakes, body seals (doors, sunroof, windows etc.) or at any components which may be damaged (lights, mirrors, exterior trim etc.).
- !** CAUTION: Do not use a power wash system in the engine bay area as it may cause damage.
- !** CAUTION: Ensure that you read and comply with all warnings and product instructions supplied with any cleaning products.
- !** CAUTION: Never use cleaning products that are not approved for use on vehicles.
- !** CAUTION: Following cleaning of the vehicle exterior (particularly with a pressure washer), it is recommended that the vehicle is taken for a short drive to dry out the brakes.
- !** CAUTION: Substances which are corrosive, such as bird droppings, can damage the vehicle's paintwork and should be removed as soon as possible.

UNDERBODY MAINTENANCE

Regularly flush the underbody with plain water, and pay particular attention to areas where mud and debris collect.

If damage or corrosion are detected, have the vehicle checked by a Land Rover Retailer/ Authorized Repairer as soon as possible.

CLEANING AFTER OFF-ROAD DRIVING

- !** CAUTION: Ensure that the areas around air intakes and the front grille are clean and clear of debris. Pay particular attention to the lower grille and radiator. Failure to do so may cause the engine to overheat, leading to severe engine damage.

Ensure that the vehicle underside is cleaned as soon as possible after driving off-road.

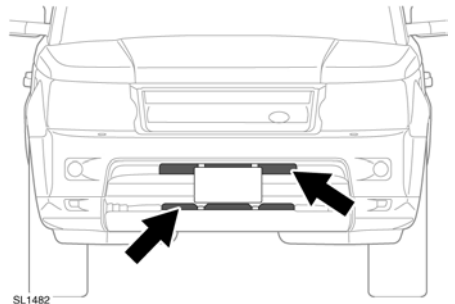

Using a hose pipe, direct clean water through the front bumper (where shown), to remove mud on the radiator and air conditioning condenser.

CLEANING THE INTERIOR

- !** **WARNING: Some cleaning products contain substances that are harmful and can cause health problems if used incorrectly and may cause damage to the interior.**

PLASTIC AND CLOTH



WARNING: Do not polish the instrument panel. Polished surfaces are reflective, and may interfere with the drivers view.

Clean plastic or cloth faced surfaces with warm water and non-detergent soap. Then wipe clean with a soft cloth.

LEATHER



CAUTION: Only use cleaning products specifically designed for use on leather. Do not use chemical, alcohol, or abrasive materials, as they will cause rapid deterioration of the leather. The use of products which are not approved will invalidate your warranty.



CAUTION: If you are in any doubt as to which products to use, consult your Land Rover Retailer/authorized Repairer/Approved Repairer.



CAUTION: Some materials/fabrics are prone to dye transfer, which can cause unsightly discoloration of lighter colored leathers. Affected areas should be cleaned and re-protected as soon as possible.

Leather should be cleaned and protected at least every six months.

To prevent ingrained dirt and staining, inspect the seat upholstery regularly, and clean every 1 to 2 months as follows:

1. Wipe off fine dust from the seat surfaces using a clean, damp, non-colored cloth. Avoid over wetting the leather.
2. If this is not sufficient, use a cloth which has been dampened with warm soapy water and then wrung out. Use only mild non-caustic soap.

3. Use Land Rover leather cleaner for heavily soiled areas. Dry off and rub the with a clean soft cloth, changing surfaces regularly.

Use Land Rover leather cleaner several times a year to maintain the leather's suppleness and appearance. The cleaner will nourish and moisturize and help to improve the surface protection film against dust and substances.

- Dark clothing may stain leather seats just like other upholstery products.
- Sharp objects such as belts, zippers, rivets etc can leave permanent scratches and scratch marks on the leather surface.
- Unless spillages such as tea, coffee or ink are washed away immediately, permanent staining may have to be accepted.

If a valet service is used, ensure that the specialist concerned is aware of, and follows, these instructions precisely.

SEAT BELTS



WARNING: Do not allow any water, cleaning products, or fabric from cloths to enter the seat belt mechanism. Any substance which enters the mechanism may affect the performance of the seat belt in an impact.

Extend the seat belts fully, then use warm water and a non-detergent soap to clean. Allow the seat belts to dry naturally while fully extended.

Note: While cleaning the seat belt, take the opportunity to examine the webbing for damage/wear. Any wear or damage should be reported to, and rectified by, a Land Rover Retailer/Authorized Repairer.

AIR BAG MODULE COVERS



WARNING: Air bag covers should only be cleaned using a slightly dampened cloth, and a small amount of upholstery cleaner.



WARNING: Do not allow the air bag covers, or surrounding areas, to become contaminated with liquids. Any substance which enters the mechanism can prevent correct deployment of an air bag during an impact.

TOUCH SCREEN CARE

- Clean with a lightly moistened cloth.
- Do not use chemical agents or domestic cleaners.
- To prevent errors occurring, ensure that only one finger at a time is in contact with the screen.
- Do not use excessive pressure.
- Do not allow sharp, hard or abrasive objects to make contact with the screen.
- Avoid exposing the screen to direct sunlight for long periods.