

Wheels and tyres

Tool kit contents

WARNING



After use the tool kit should be returned to its storage area and correctly stowed. Do not leave the tool kit, or its components, loose in the storage area as they can prove hazardous during an impact or sudden manoeuvre.

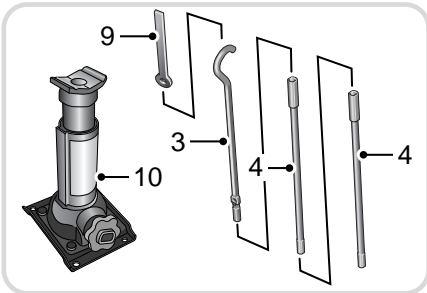
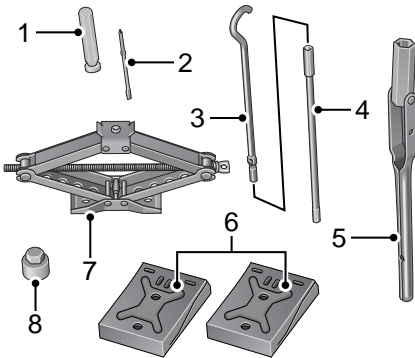

EB0454

1. Screwdriver handle
2. Screwdriver blade
3. Jack screw rotating hook
4. Extension piece
5. Wheel nut brace
6. Wheel chocks
7. Wheel change jack (air suspension)

8. Locking wheel nut adapter
9. Jack adapter (coil suspension)
10. Wheel change jack (coil suspension)

Care of the jack

The jack requires occasional maintenance. Examine the jack for wear, damage. Clean and grease the moving parts, particularly the screw thread, to prevent corrosion.

To avoid contamination, the jack should always be stowed in its fully closed position.

CHANGING A ROAD WHEEL

WARNINGS



The spare wheel is heavy and if handled incorrectly may cause injury. Use extreme caution when lifting or manoeuvring the wheels.



Always secure the spare wheel, or the removed wheel, in the correct position using the retaining bolt. Failure to do so may cause the spare wheel to move in the event of a sudden manoeuvre or accident, leading to death or serious injury.

Wheel changing safety

Before raising the vehicle or changing a wheel, ensure that you read and comply with the following warnings.

WARNINGS



Always find a safe place to stop, off of the highway and away from traffic.



Ensure that the vehicle is on firm level ground.



Disconnect any trailer/caravan from the vehicle.



Switch on the hazard warning lamps.

Wheels and tyres

WARNINGS



Ensure that all passengers and animals are out of the vehicle and in a safe place away from the highway.



Place a warning triangle at a suitable distance behind the vehicle, facing towards oncoming traffic.



Ensure that the suspension is set to off-road height.



Ensure that the front wheels are in the straight ahead position and engage the steering lock.



Apply the parking brake and engage **P** (Park) in vehicles fitted with an automatic transmission,



Apply the parking brake and engage 1st or reverse gear in vehicles fitted with a manual transmission.



Remove the spare wheel before using the jack to avoid destabilising the vehicle when raised.



Ensure that the jack is on firm level ground.



Never place anything between the jack and the ground, or the jack and the vehicle.



Always chock the wheels using suitable wheels chocks. Place the chocks on both sides of the wheel diagonally opposite the wheel to be changed.



If jacking the vehicle on a slight slope is unavoidable, place the chocks on the downhill side of the two opposite wheels.



Take care when lifting the spare wheel, and removing the punctured wheel. The wheels are heavy and can cause injuries if not handled correctly.

WARNINGS



Take care when loosening the wheel nuts. The wheel brace may slip off if not properly attached and the wheel nuts may give way suddenly. Either unexpected movement may cause injury.

Note: *Switch on the hazard warning lamps to alert other road users.*

Before changing a wheel, ensure the following:

- The suspension is set to off-road height.
- Front wheels are in the straight-ahead position.
- Electric parking brake is applied.
- **P** (Park) is selected on an automatic transmission vehicle or any gear on a manual transmission vehicle.
- Ignition is switched off.

Wheels and tyres

Spare wheel

WARNING



The wheels are extremely heavy. Take care when manoeuvring the spare wheel.

Always remove the spare wheel before jacking up the vehicle.

Spare wheel access - 5-seat vehicle

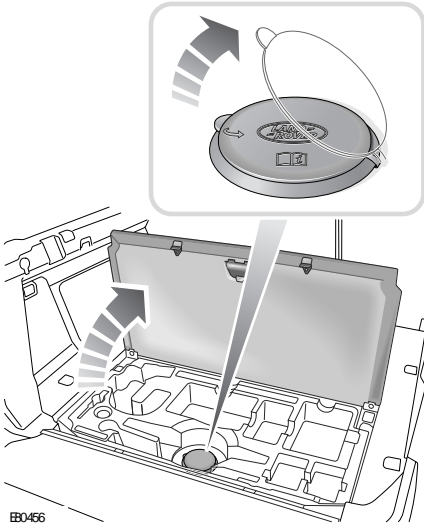

Spare wheel access - 7-seat vehicle

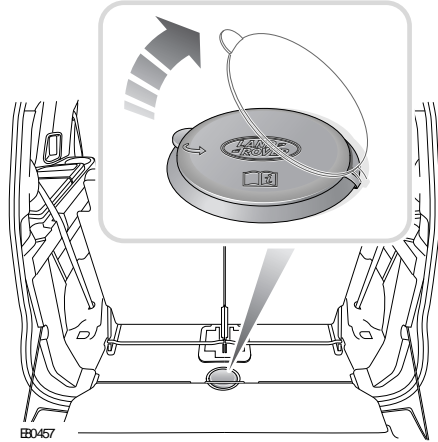

Note: Before removing the spare wheel, make a note of the position that it is stowed in. The wheel which is to be removed from the vehicle must be correctly stowed in its place.

Wheels and tyres

Lowering the spare wheel

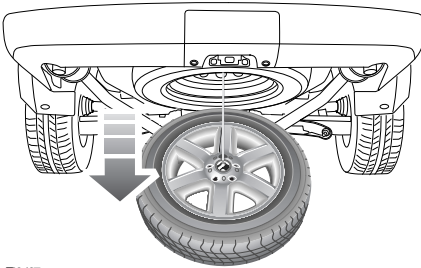
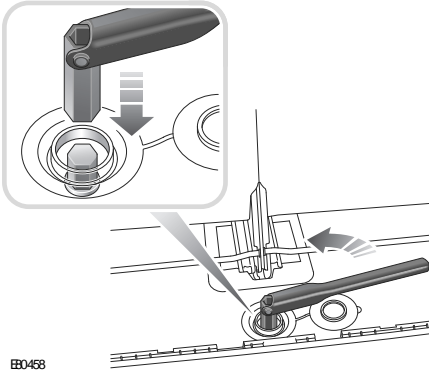

CAUTION

! Do not use power tools to lower the spare wheel. Doing so may damage the mechanism.

1. Open the spare wheel access hatch in the loadspace area.
 - 5-seat vehicles, remove the jack from the tool tray.
2. Lift the cap covering the spare wheel-hoist winch nut.

3. Fit the wheel nut brace to the wheel-hoist winch nut and rotate counterclockwise to lower the spare wheel. The mechanism has been designed for use with the wheel nut brace.
4. Continue to turn the wheel-hoist winch nut until the wheel is on the ground and the cable is slack. Do not attempt to turn the winch nut beyond the physical stop.

Note: 7-seat vehicles: The wheel-hoist winch nut is close to the back of the rear seats. Turn the wheel nut brace as far as possible counterclockwise and then rotate the handle over the top of the nut and continue to turn it.

Releasing the wheel

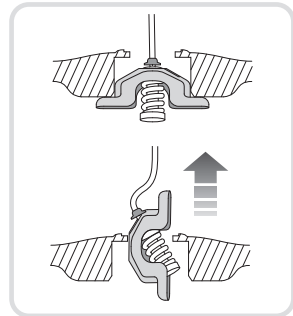
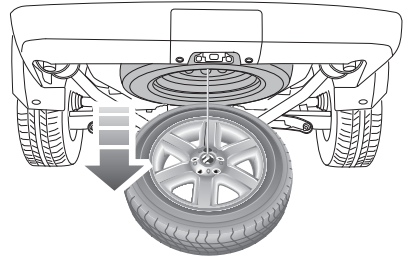

- Hold the cable and tilt the lifting lug until it can be lifted through the hole in the wheel, as shown in the illustration.

Wheels and tyres

Using wheel chocks

WARNING



Before raising the vehicle the road wheel diagonally opposite the one to be removed must be chocked.



LAN2348

The wheel chocks are stowed in the tool kit.

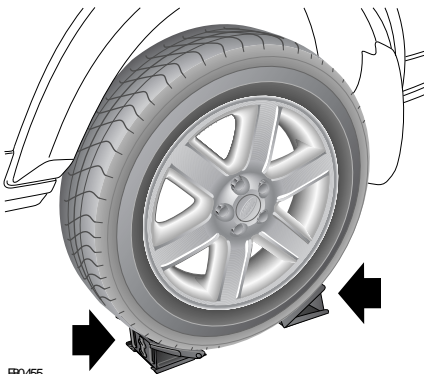

Position the vehicle on level ground. Chock the road wheel diagonally opposite the one to be removed.

Both chocks must be used on opposite sides of the road wheel and must be fully pushed home against the tyre

Note: If jacking the vehicle on a slope is unavoidable, place the chocks on the downhill side of the two opposite wheels.

Raising the vehicle (Air suspension)

WARNINGS



Ensure that the air suspension is set to off-road height.



Always remove the spare wheel before jacking up the vehicle.



The jack is designed for wheel changing only. Never work beneath the vehicle with the jack as the only means of support. Always use the vehicle support stands before putting any portion of your body beneath the vehicle.



Always place the jack on firm, level ground.



Always position the jack from the side of the vehicle, in line with the appropriate jacking point.



Always use the complete, two-piece, jack lever throughout to minimise any chance of accidental damage or injury.

CAUTION



Only jack the vehicle using the jacking points described, or damage to the vehicle could occur.

Note: Your vehicle may be fitted with a tilt sensor which activates the alarm if the vehicle is tilted in any direction after it has been locked. If you wish to have the doors locked while jacking up the vehicle, turn off the alarm sensors via the vehicle information and settings menu. See **VEHICLE INFORMATION AND SETTINGS MENU** (page 33).

Wheels and tyres

Jacking points

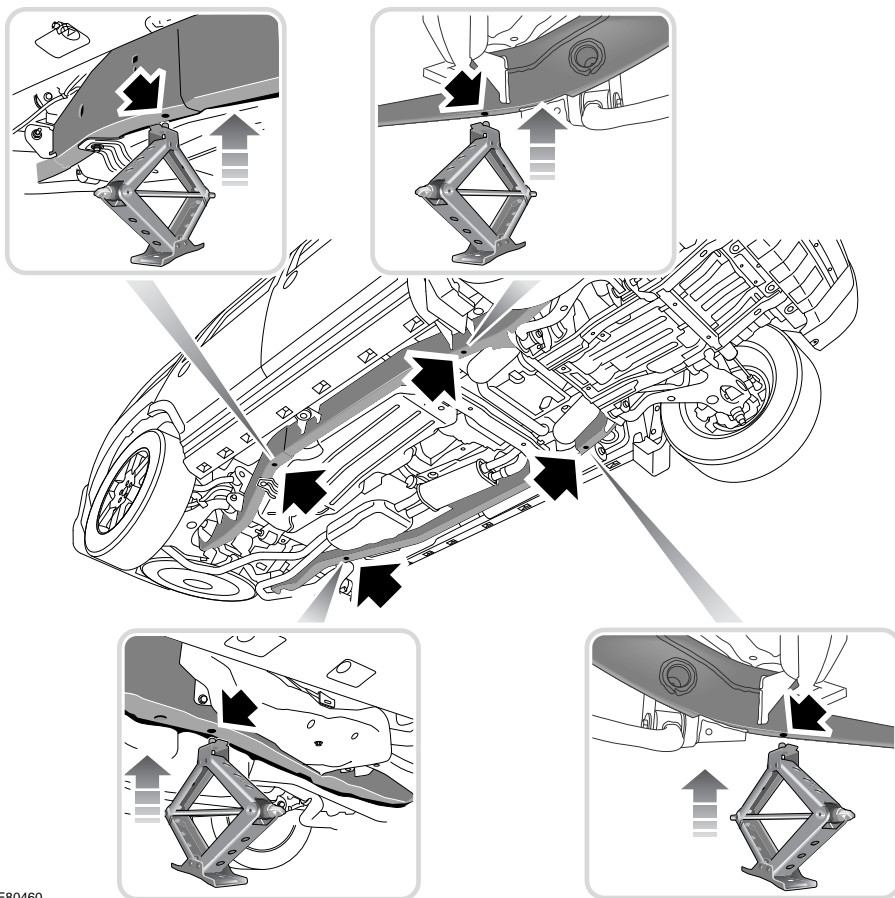

E80460

Wheels and tyres

Operating the jack

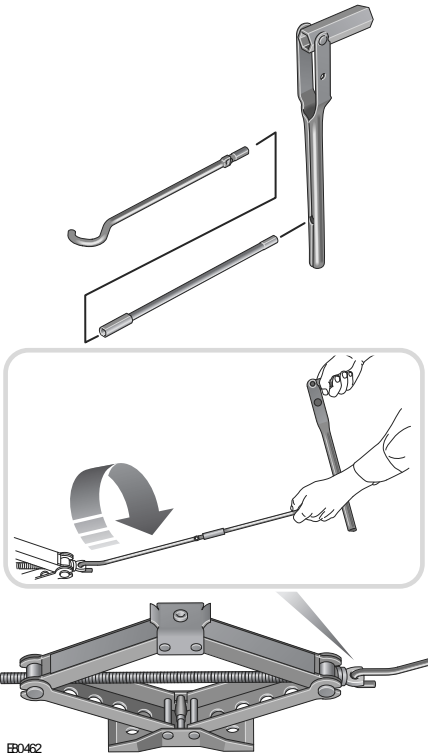



EB0462

1. Attach the jack cranking lever to the jack. Fit the wheel nut brace onto the end of the cranking lever.

Positioning the jack

WARNINGS

 Never work beneath the vehicle, or place any part of your body beneath the vehicle with the jack as the only means of support. Always use suitable vehicle support stands which are approved for the weight of the vehicle.

 Ensure that the jack is correctly located onto the jacking points.

1. Before raising the vehicle, use the wheel nut brace to slacken the wheel nuts half a turn counterclockwise.
2. Position the jack beneath the jacking point, ensuring that the pin on the jack head aligns with the hole in the chassis.
3. Turn the jack lever clockwise to raise the jack cradle until it engages with the jacking point. Ensure that the base of the jack is in full contact with the road surface.

Wheels and tyres

Raising the vehicle (Coil suspension)

WARNINGS



Always remove the spare wheel before jacking up the vehicle.



Never work beneath the vehicle with the jack as the only means of support. Always use approved vehicle support stands before putting any portion of your body beneath the vehicle.



The jack is designed for wheel changing only.



Do not attempt to raise the vehicle using any position other than the jacking points illustrated.



Due to the nature of coil suspension systems, it is not possible to raise the wheel clear of the road surface by jacking under the chassis.



Always place the jack on firm, level ground.



Always position the jack from the side of the vehicle, in line with the appropriate jacking point.

Note: *Your vehicle may be fitted with a tilt sensor which activates the alarm if the vehicle is tilted in any direction after it has been locked. If you wish to have the doors locked while jacking up the vehicle, turn off the alarm sensors via the vehicle information and settings menu. See **VEHICLE INFORMATION AND SETTINGS MENU** (page 33).*

Wheels and tyres

Jacking points

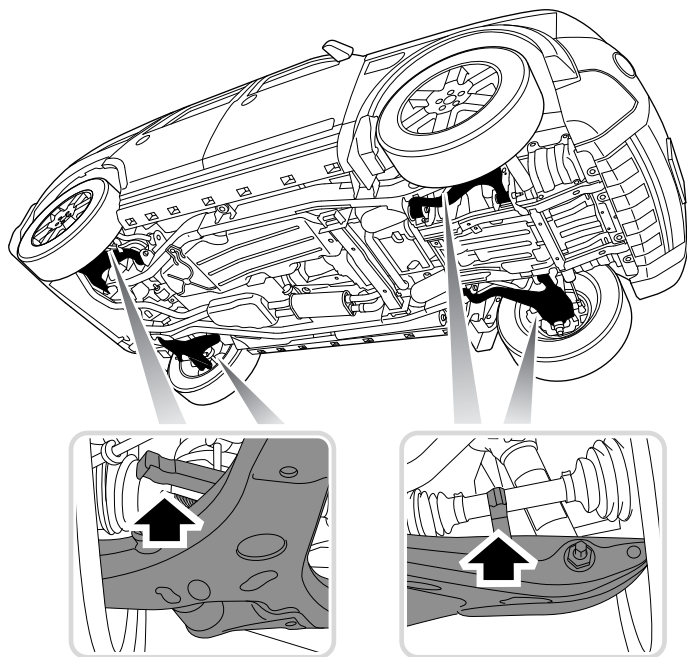

EQ0463

Wheels and tyres

Operating the jack

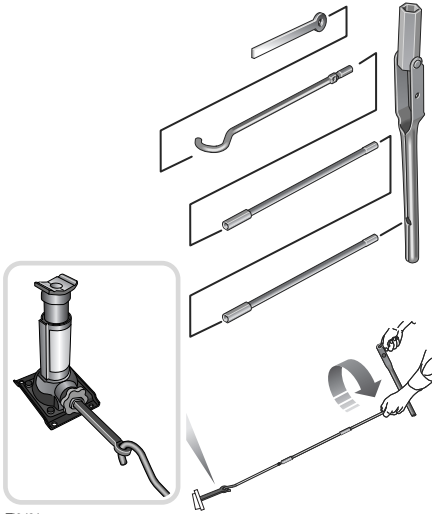

1. Attach the jack cranking lever to the jack using the adapter. Fit the wheel nut brace onto the end of the cranking lever.

Positioning the jack

WARNINGS



Never work beneath the vehicle, or place any part of your body beneath the vehicle with the jack as the only means of support. Always use suitable vehicle support stands which are approved for the weight of the vehicle.



Ensure that the jack is correctly located onto the jacking points.

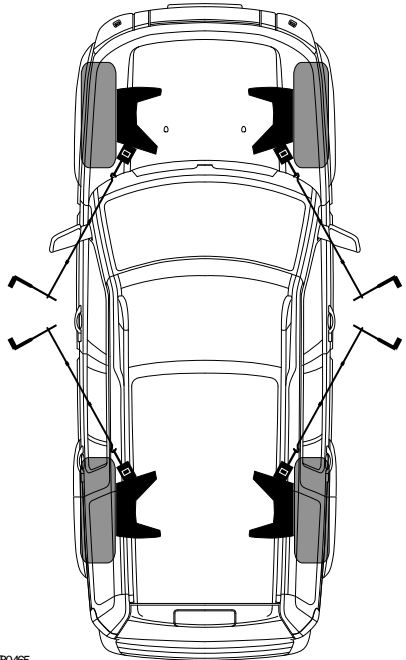

1. Before raising the vehicle, use the wheel nut brace to slacken the wheel nuts half a turn counterclockwise.
2. Position the jack beneath the relevant suspension arm.
3. Turn the jack lever clockwise to raise the jack cradle until it engages with the jacking point. Ensure that the base of the jack is in full contact with the road surface.

Wheels and tyres

Wheel changing

1. Read and observe the warnings in **Wheel changing safety**.
2. Loosen the wheel nuts half a turn (counterclockwise).
3. Position the jack under the relevant jacking point.
4. Raise the vehicle using the jack with a slow steady operation. Avoid rapid, jerky actions as they may cause the vehicle/jack to become unstable.
5. Remove the wheel nuts and place them together where they cannot roll away.
6. Remove the wheel and place to one side. Do not lay the wheel on its face as this may damage the finish.
7. Fit the spare wheel to the hub.
8. Re-fit the wheel nuts and lightly tighten them. Ensure that the wheel is making contact with the hub evenly.
9. Ensure that the space under the vehicle is clear of obstructions and lower the vehicle slowly and smoothly.
10. With all the wheel on the ground and the jack removed, fully tighten the wheel nuts.
11. If an alloy spare wheel is to be fitted, using a suitable blunt tool, knock the centre cap out of the removed wheel. Using hand pressure only, press the centre cap into the newly fitted spare wheel.
12. Check and adjust the tyre pressure as soon as possible.

Wheel nut tightening sequence

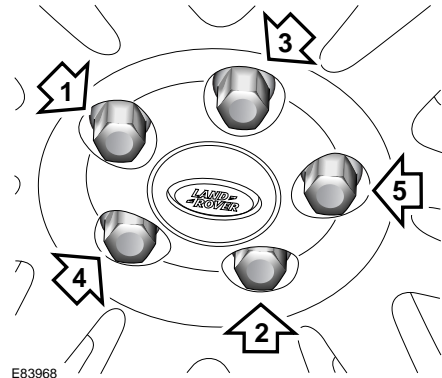

With all wheels on the ground and the jack removed, fully tighten the wheel nuts in the sequence shown to 140 Nm (103lb.ft)

Note: If it not possible to torque the wheel nuts when a wheel is replaced, the wheel nuts should be set to the correct torque as soon as possible.

Wheels and tyres

Temporary spare wheel

WARNINGS



You must comply with the instructions given on the warning label affixed to the temporary spare wheel. Failure to do so may result in incorrect use of the temporary spare wheel. This may cause vehicle instability and/or tyre failure.



Drive with caution while the temporary spare wheel is fitted and ensure that an original size wheel and tyre are fitted as soon as possible.



Do not drive the vehicle with more than one temporary spare wheel fitted.



Do not exceed 80 km/h (50 mph) while the temporary spare wheel is fitted.



The tyre pressure in the temporary spare wheel/tyre should be 420 kPa (4.2 bar/60 lbf/in²).



The use of snow chains is not permitted on a temporary spare wheel.



DSC must be switched on while the temporary spare wheel is in use.

Locking wheel nuts

WARNING



Ensure that the locking wheel nut adapter is fully engaged onto the wheel nut before attempting to turn. Failure to do so may cause the key to slip resulting in injury.

Vehicles may be equipped with a locking wheel nut on each wheel. These can only be removed using the special adapter provided in the tool kit.

Note: A code number is stamped on the underside of the adapter. Ensure the number is recorded on the Security Information card supplied with the literature pack. Quote this number if a replacement is required. Do not keep the Security Information card in the vehicle.

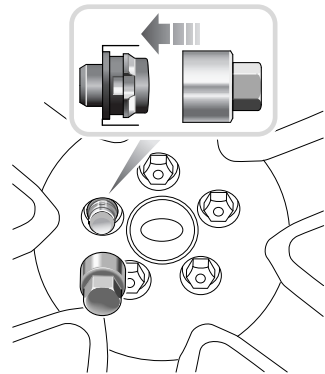

EBD466

Insert the adapter firmly onto the locking wheel nut.

Using the wheel nut brace, unscrew the wheel nut and adapter.

Be sure to return the locking wheel nut adapter to the correct storage position.

Wheels and tyres

Stowing the changed wheel

WARNING



Do not stow the wheel while the vehicle is still raised on the jack.

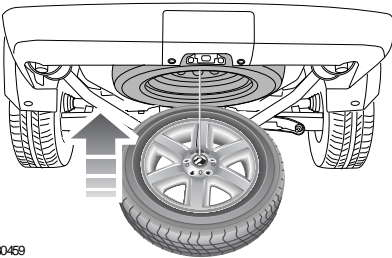
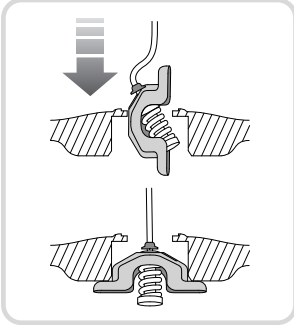

BB0469

CAUTION



Do not use power tools to raise the spare wheel. Doing so may damage the mechanism.

1. Place the wheel under the rear of the vehicle with its style surface uppermost.
2. Place the lifting lug through the wheel aperture and locate it in position.
3. Winch up the wheel using the wheel-hoist mechanism.

4. Continue to wind up until the mechanism clutches out. This is confirmed by a clear physical indication from the wheel nut brace and an audible noise.
5. Check that the wheel has returned to the same position as the spare wheel as previously noted. If in any doubt, unwind the winch slightly and repeat the previous step.

The wheel must be securely retained in its correct position by the winch mechanism or it could become loose.

6. Replace the locking cap over the wheel-hoist nut. As the underside of this cap is exposed to the same conditions as the underside of the vehicle, ensure that it is firmly in place.

Note: If, for any reason, the spare wheel is not to be fitted back in its hoist, the wheel hoist should be rewound as follows.

Position the lifting lug level on the cable and wind up the wheel hoist mechanism until it clutches out.