



Tyre pressure monitoring system

TYRE PRESSURE MONITORING (TPM) SYSTEM

 The TPM system provides a low pressure warning and does not re-inflate your tyres. Tyre pressures should be checked regularly using an accurate pressure gauge when cold.

 The TPM system can NOT register damage to a tyre. Regularly check the condition of your tyres, especially if the vehicle is driven off-road.

 When inflating tyres, care should be taken to avoid bending or damaging the TPM system valves. Always ensure correct alignment of the inflation head to the valve stem.

Note: Non-approved accessories may interfere with the system. If this occurs, **TYRE PRESSURE MONITORING SYSTEM FAULT** is displayed in the message centre.

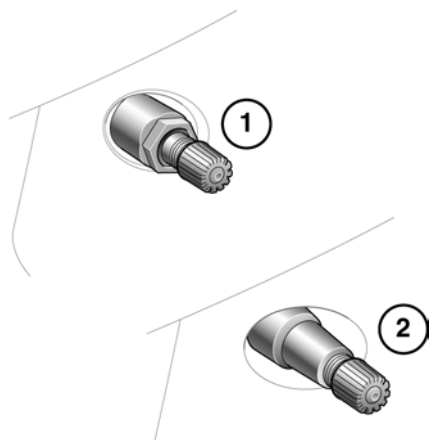

SJ1063

Wheels fitted with a TPM system can be visually identified by the external metal lock nut and valve (1). All Jaguar non-TPM system wheels have a rubber valve fitted (2).

TPM SYSTEM OPERATION

The TPM system monitors pressure of the tyres via sensors located in each wheel and a receiver located within the vehicle.

Communication between sensor and receiver is via Radio Frequency (RF) signals.



The tyre pressure warning comprises a yellow warning telltale within the instrument panel and the associated messages within the message centre.

If the telltale light illuminates, you should stop and check your tyres as soon as possible and inflate them to the recommended pressure as stated on the tyre pressure placard. If low pressure warnings occur frequently, the cause must be determined and rectified.

When driving through variable climatic conditions the TPM system warnings may be intermittent.

Your vehicle will also indicate a TPM system malfunction by initially flashing and subsequent continuous illumination of the warning telltale. A text message will accompany the system malfunction and will display **TYRE PRESSURE MONITORING SYSTEM FAULT**. The TPM system fault sequence will be activated at every ignition cycle until the fault is rectified. When a malfunction occurs, the system may not be able to detect or signal low tyre pressure as intended.

TPM system malfunctions may occur for a variety of reasons which may include other radio frequency systems that could cause interference or the installation of incompatible replacement tyres on the vehicle.

TEMPORARY USE SPARE WHEEL AND TYRE CHANGE

If the temporary use spare wheel is fitted the system will automatically recognise the change in wheel positions. Then after approximately ten minutes of driving above 25 km/h (18 mph), a message detailing which tyre is affected (e.g. **FRONT LEFT**) and **TYRE NOT MONITORED** will be displayed accompanied by illumination of the warning telltale and the corresponding block in the vehicle graphic.

The warning telltale will initially flash and will subsequently revert to continuous illumination. Extended use of the temporary use spare wheel will produce an additional text message **TYRE PRESSURE MONITORING SYSTEM FAULT**.

This TPM system display sequence will be activated at every ignition cycle until the temporary use spare wheel is replaced by a fully operational full size wheel and tyre assembly.

Always replace the temporary use wheel before having TPM system faults investigated. The fault may well be rectified with the fitment of a fully operational full size running tyre in lieu of the temporary use spare wheel assembly.

TYRE PRESSURE MONITORING UNAVAILABLE

If all four running wheels and tyres are changed for a set that are not fitted with TPM system sensors (e.g. a set of winter wheels and tyres), the message **TYRE PRESSURE MONITORING UNAVAILABLE** is displayed. TPM system sensors must be fitted to the wheels and tyres for the system to be able to warn of low tyre pressures.

When sensors are fitted to the replacement wheel and tyre set, the vehicle needs to be driven until the TPM system recognizes the sensors before TPM will be available (**TYRE PRESSURE MONITORING AVAILABLE** is displayed).

TYRE CHANGING

Always have your tyres serviced or changed by a qualified technician.

Care must be taken to avoid contact between the bead of the tyre and the sensor during removal and refitting of the tyre, otherwise the sensor may become damaged and or inoperable.



Valve stem seal, washer, nut, valve core and cap should be replaced at every tyre change. Valve stem seal, washer and nut must be replaced if valve retention nut is loosened. Sensor units and nuts must be refitted using correct torque figures and associated profile. Damage to the vehicle may result if these precautions are not taken.

Sensors can be removed from the wheel by the unscrewing of the valve retention nut.

REPLACEMENT SENSOR

Should the sensor require replacing, it should be carried out by a Dealer/Authorised Repairer.

A replacement sensor must be fitted to a running wheel in order to be recognised by the system. The vehicle needs to be stationary for 15 minutes during the sensor fitment before the system is ready to detect the new sensor. The vehicle must be driven for a minimum of fifteen minutes after the sensor change, and then remain stationary for fifteen minutes to activate full TPM system operation.

Tyre pressure monitoring system

If the TPM system warning for any wheel does not clear, even after ensuring correct inflation and driving for more than ten minutes above 25 km/h (18 mph), you should seek qualified assistance as soon as possible.