



ACCESSORIES

WARNING

Accessories which are not properly fitted can be dangerous. Read the instructions carefully prior to fitting. Whilst fitting, comply with the instructions at all times. If in doubt, contact your nearest Land Rover Dealer.

ACHTUNG!

Nicht sachgemäß montiertes Zubehör kann gefährlich sein. Lesen Sie die Montageanleitung sorgfältig, bevor Sie das Teil montieren. Halten Sie sich bei der Montage an die Anleitung. Bei Unsicherheiten wenden Sie sich bitte an Ihren Land Rover Händler.

AVERTISSEMENT

Les accessoires qui ne sont pas correctement montés risquent d'être dangereux. Veuillez lire soigneusement les instructions avant d'effectuer la pose. Respectez toujours les instructions en cours de pose. En cas de doute, consultez votre concessionnaire Land Rover local.

AVVERTENZA

Gli accessori non sistemati come previsto possono essere pericolosi. Leggere attentamente le istruzioni prima del fissaggio. Durante il montaggio seguire sempre le relative istruzioni. In caso di dubbio rivolgersi al più vicino concessionario della Land Rover.

AVISO

Aquellos accesorios que no hayan sido ajustados debidamente pueden resultar peligrosos. Lea las instrucciones detenidamente antes de iniciar el montaje. Durante el montaje siga las instrucciones en todo momento. En caso de duda póngase en contacto con su Concesionario de Land Rover.

ADVERTÊNCIA!

Os Acessórios que não são montados adequadamente podem ser perigosos. Leia as instruções cuidadosamente antes de montar. Durante a montagem, obedeça as instruções todo o tempo. Se tiver alguma dúvida, contacte o Concessionário Land Rover mais próximo.

WAARSHCUWING

Accessoires die niet op de juiste wijze zijn gemonteerd kunnen gevaar opleveren. Lees zorgvuldig de instructies alvorens met de montage te beginnen. Houd u tijdens de montage te allen tijde aan de instructies. Neem bij twijfel contact op met de dichtstbijzijnde Land Rover dealer.

ΠΡΟΕΙΔΟΠΟΙΗΣΗ

Τα προαιρετικά εξαρτήματα που δεν έχουν τοποθετηθεί σωστά μπορεί να είναι επικίνδυνα. Διαβάστε τις οδηγίες πριν προχωρήσετε στην τοποθέτησή τους. Κατά την τοποθέτησή, τηρείτε συνεχώς τις οδηγίες. Αν έχετε οποιαδήποτε αμφιβολία, επικοινωνήστε με τον πλησιέστερο αντιπρόσωπο της.

注意

正しく取り付けられていない備品があると、事故の原因になります。取付ける前にこのマニュアルをよくお読みください。取付けの際は必ずこのマニュアルにある指示に従ってください。何か不明な点がありましたら、お近くのランド・ローバー社のディーラーまでお問い合わせください。



FITTING INSTRUCTION

Towing Kit

EINBAUANLEITUNG

Einbausatz Anhängervorrichtung

INSTRUCTION DE MONTAGE

Lot de dispositif d'attelage

ISTRUZIONI PER L'USO

Kit di montaggio per
dispositivo di traino

INSTRUCCIONES DE MONTAJE

Juego de montaje para
dispositivo de remolque

INSTRUÇÕES DE MONTAGEM

Jogo de montagem para esfera
de acoplamento de reboque

MONTAGEHANDLEIDING

Set de montage voor trekhaak

ΟΔΗΓΙΑ ΤΟΠΟΘΕΤΗΣΗΣ

Κιτ Ρυμούλκησης

取付用マニュアル
牽引キット

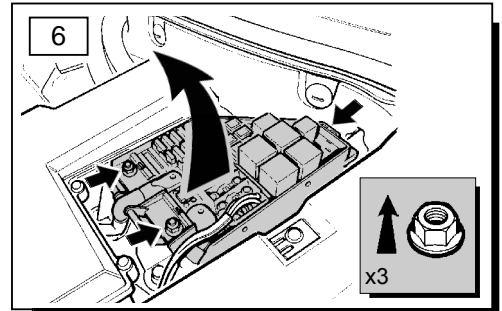
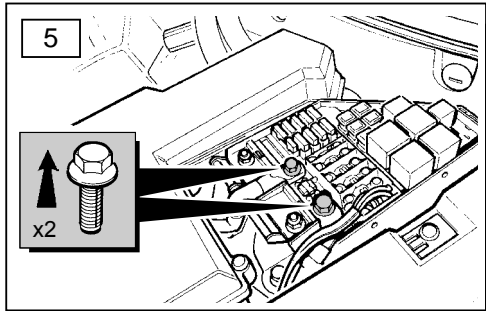
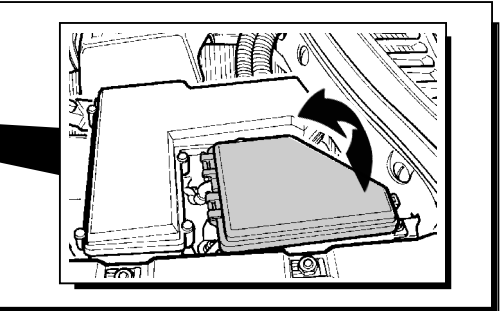
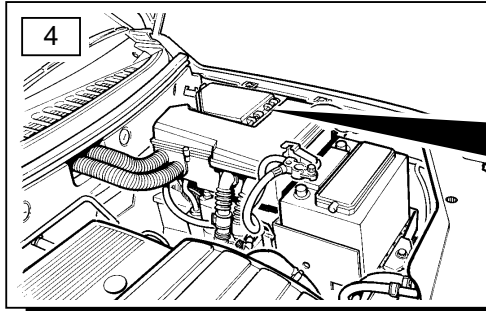
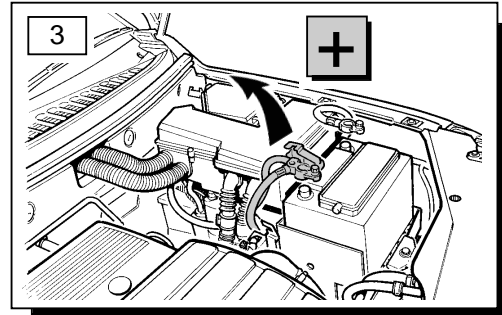
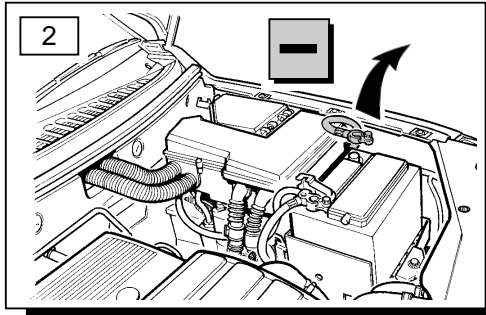
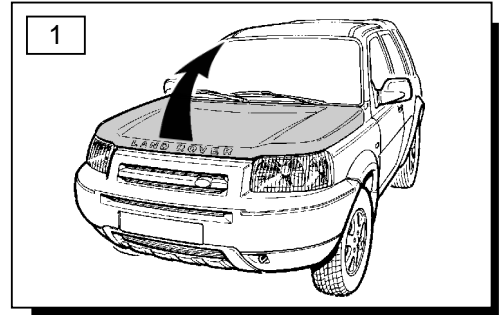
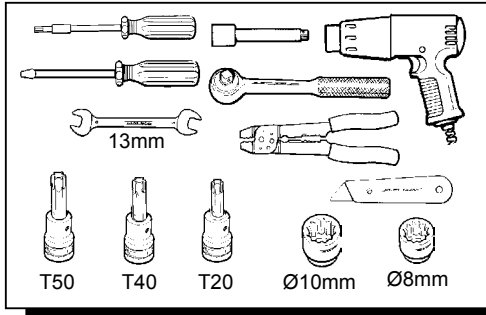
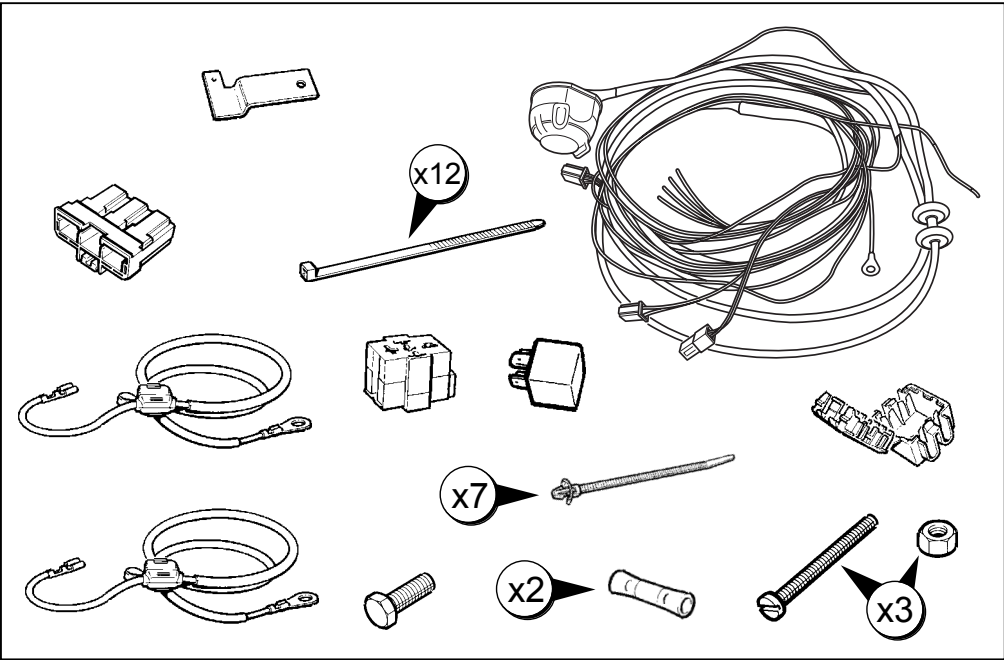
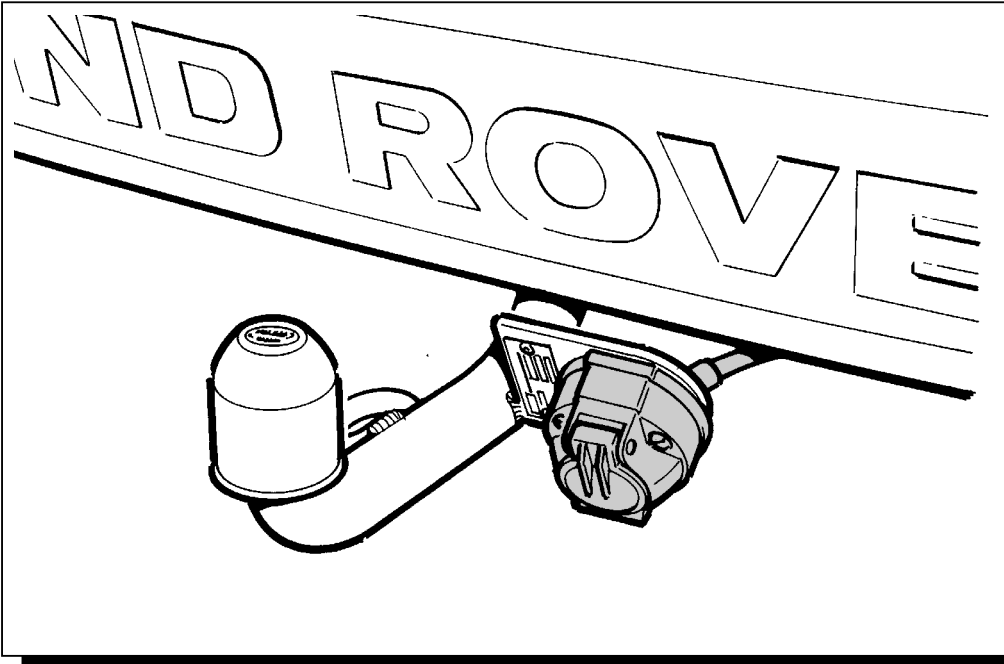

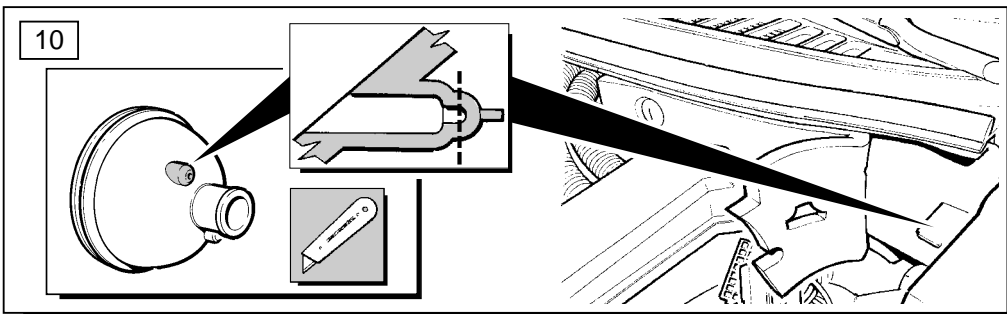
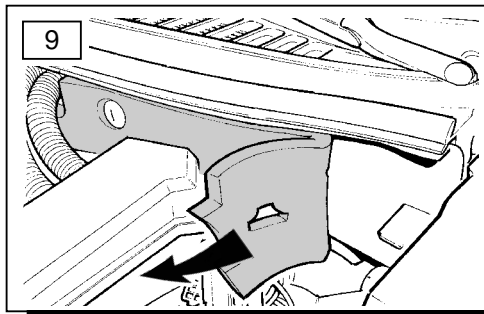
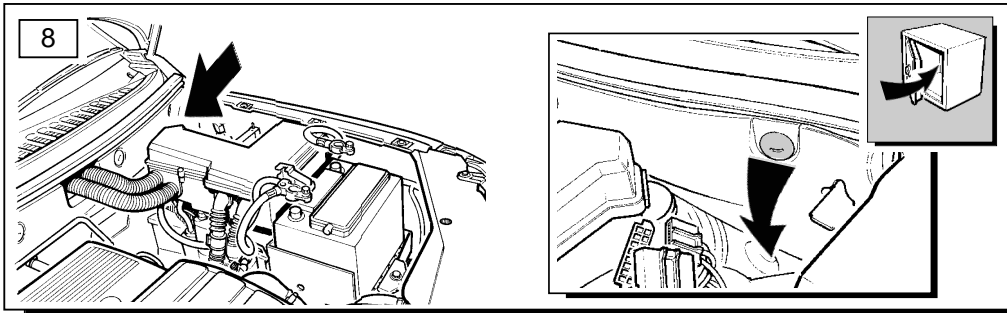
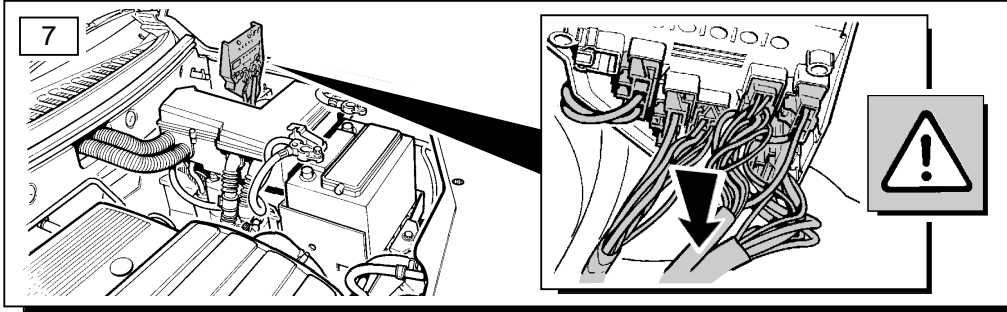

GB	3 Door Only
D	Nur 3-Tür.
F	3 portes uniquement.
I	3 porte solamente.
E	3 puertas solamente.
P	Apenas 3 portas.
NL	Alleen driedeurs.
GR	3-πορτα μόνο
H	3 ドアのみ

GB Follow procedures 11 to 20 then 29 onwards.
D Vorgänge 11 bis 20 und dann ab 29 durchführen.
F Suivre les procédures de 11 à 20 puis à partir de 29.
I Seguire le procedure da 11 a 20 e poi da 29 in avanti.
E Seguir los procedimientos 11 hasta 20 y luego de 29 en adelante.
P Siga os procedimentos 11 a 20 a, seguir de 29 em diante.
NL Verricht handelingen 11 t/m 20 en vanaf 29.
GR Ακολουθήστε τις διαδικασίες 11 έως 20 και κατόπιν από την 29 και μετά.
H まず、11から20の手順に従い、その後29以降の手順に従います。

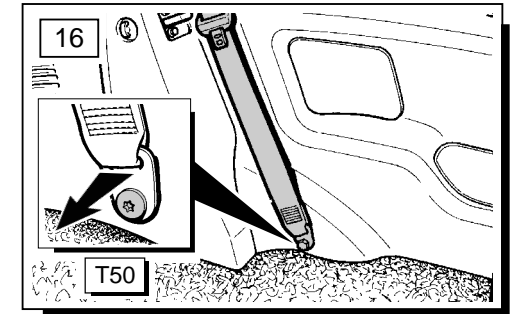
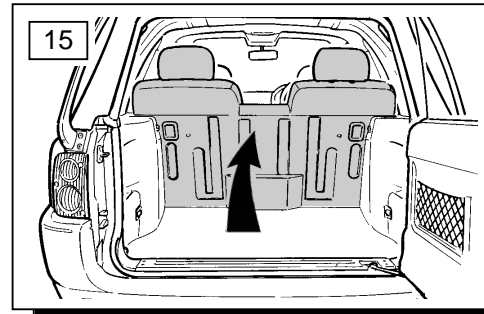
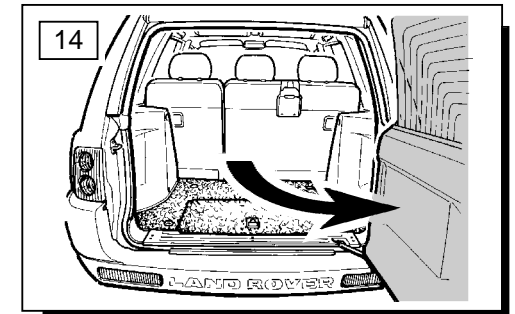
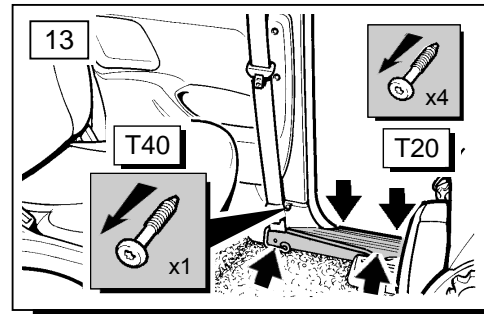
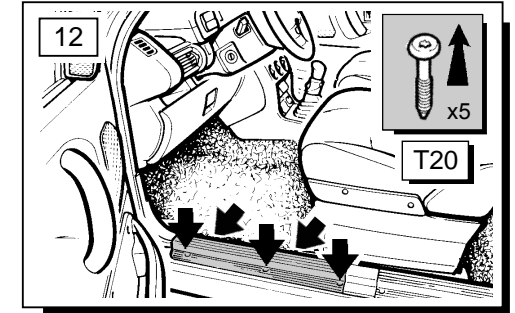
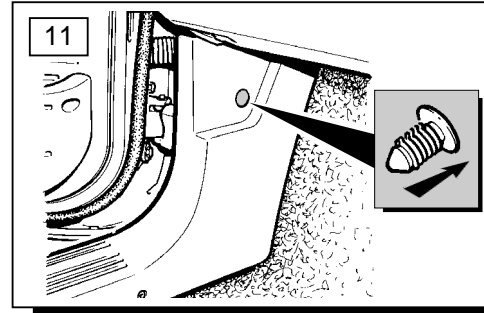

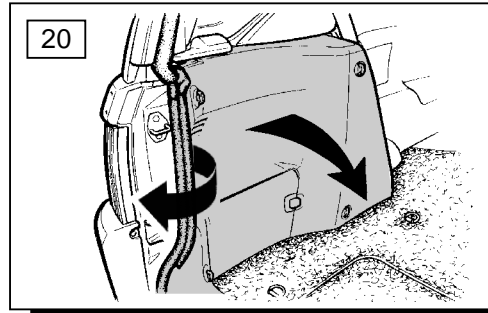
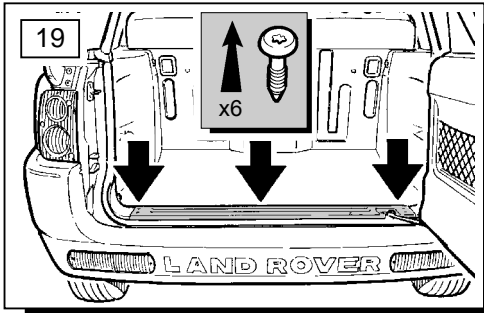
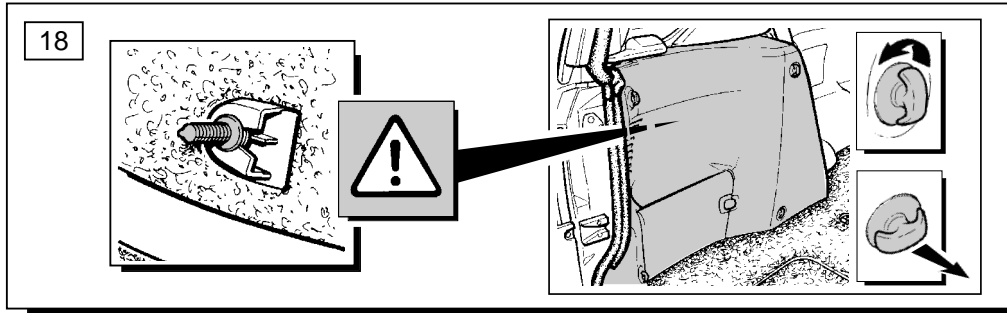
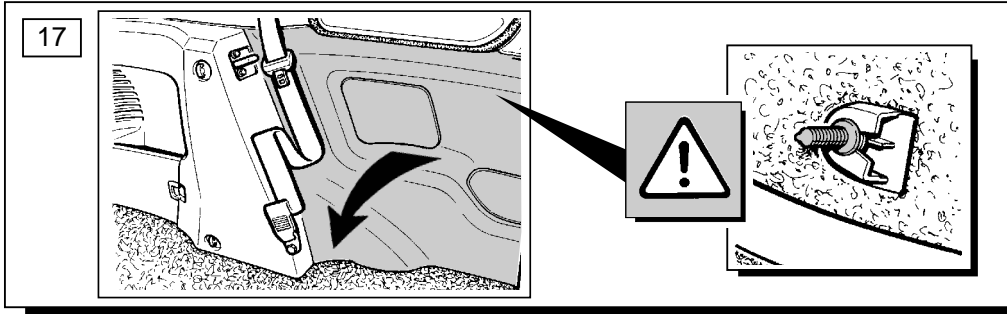

- (GB) 5 Door Only
- (D) Nur 5-Tür.
- (F) 5 portes uniquement.
- (I) 5 porte solamente.
- (E) 5 puertas solamente.
- (P) Apenas 5 portas.
- (NL) Alleen vijfdeurs.
- (GR) 5-πορτα μόνο
- (B) 5 ドアのみ

- (GB) Follow procedures 21 to 28 then 29 onwards.
- (D) Vorgänge 21 bis 28 und dann ab 29 durchführen.
- (F) Suivre les procédures de 21 à 28 puis à partir de 29.
- (I) Seguire le procedure da 21 a 28 e poi da 29 in avanti.
- (E) Seguir los procedimientos 21 hasta 28 y luego de 29 en adelante.
- (P) Siga os procedimentos 21 a 28 a, seguir de 29 em diante.
- (NL) Verricht handelingen 21 t/m 28 en vanaf 29.
- (GR) Ακολουθήστε τις διαδικασίες 21 έως 28 και κατόπιν από την 29 και μετά.
- (B) まず、21 から28の手順に従い、その後 29以降の手順に従います。

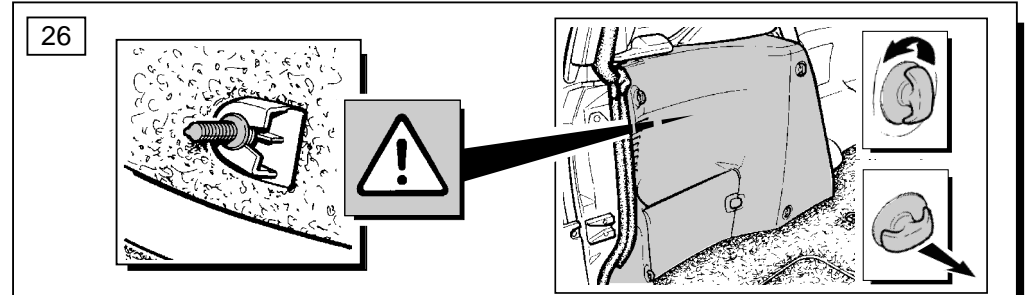
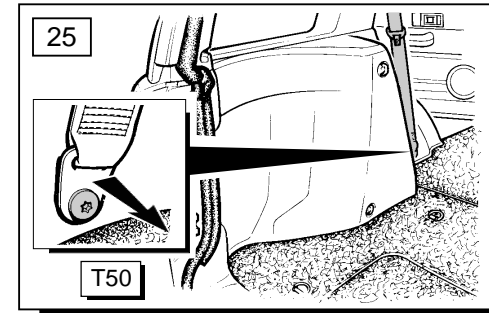
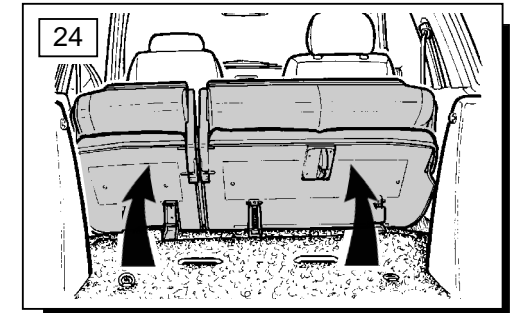
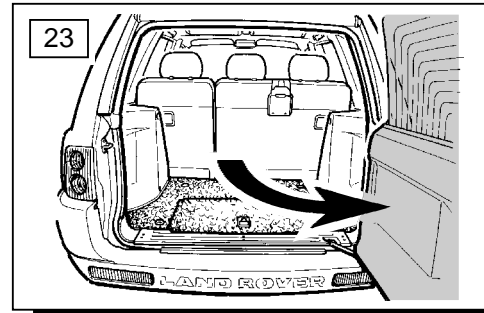
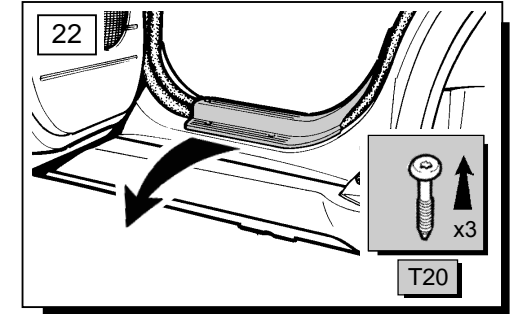
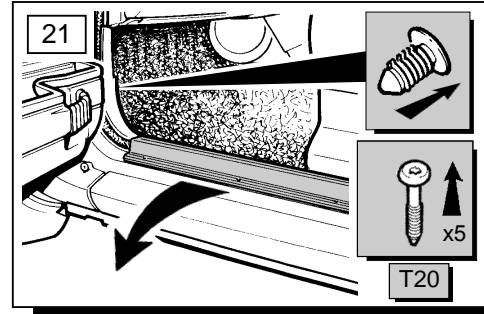

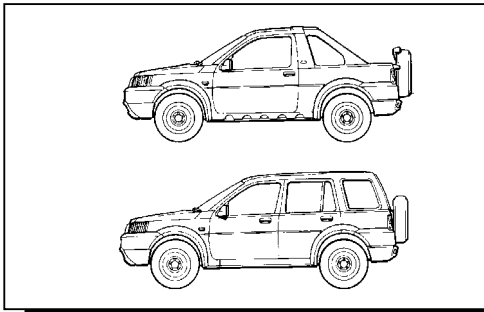
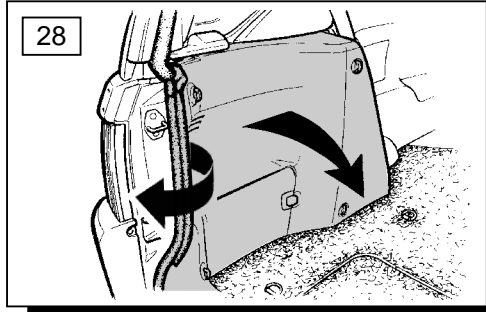
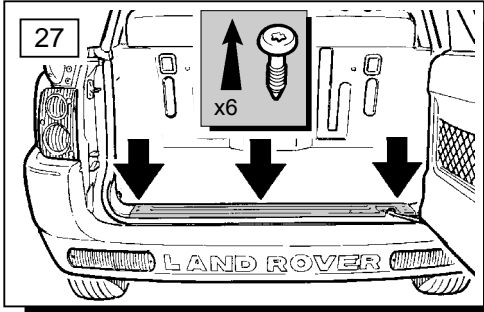

- (GB)** 3 and 5 door vehicles
- (D)** 3-türige und 5-türige Fahrzeuge
- (F)** Véhicule à trois et cinq portes
- (I)** Veicoli da 3 e 5 portiere.
- (E)** Vehículos de 3 y 5 puertas
- (P)** veículos de 3 e 5 portas
- (NL)** Drie- en vijfdeurs modellen
- (GR)** 3-πορτα και 5-πορτα οχήματα.
- (B)** 3 ドア車と 5 ドア車

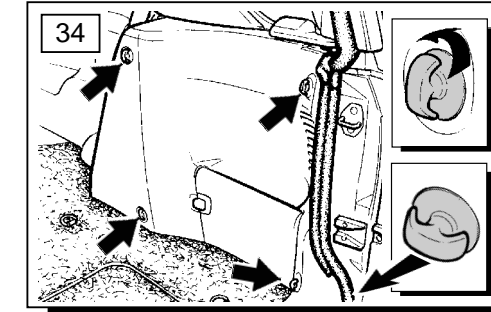
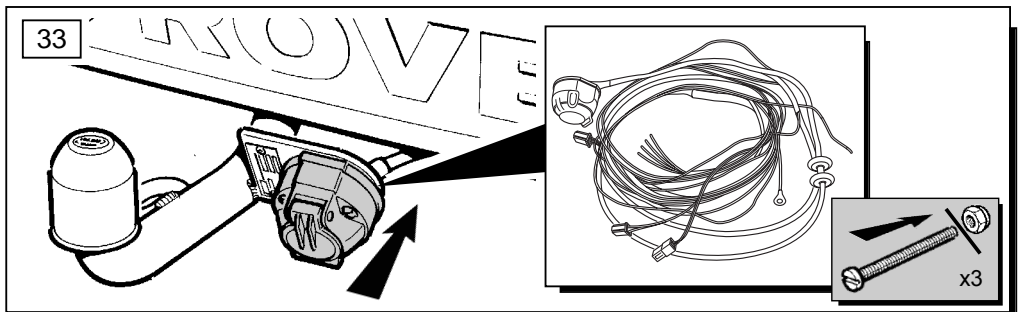
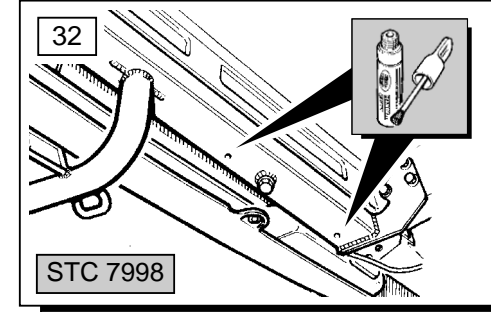
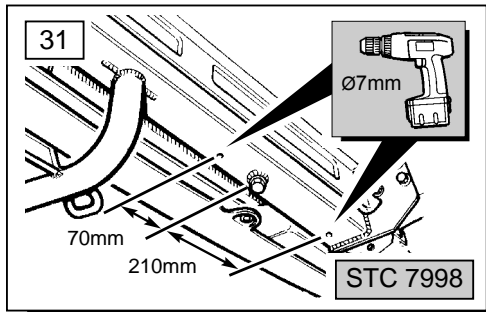
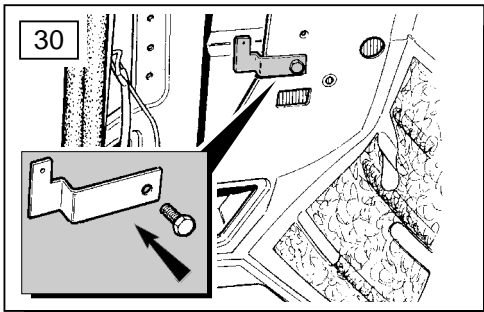
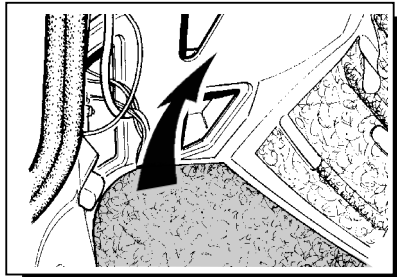
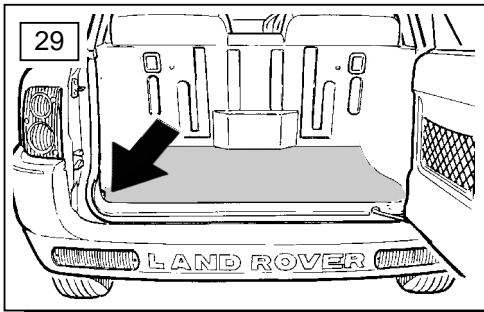

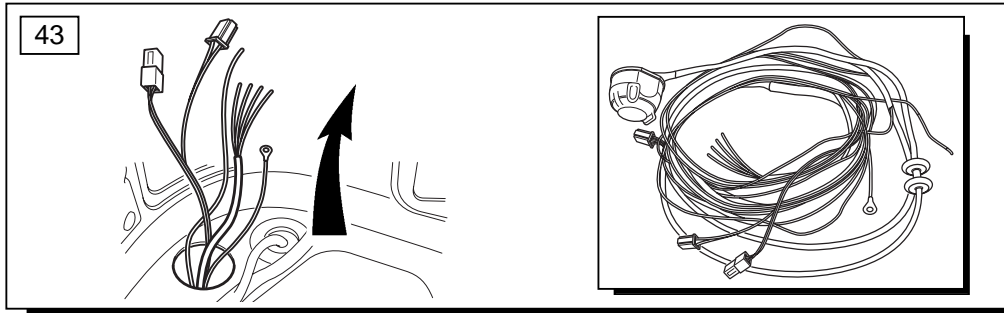
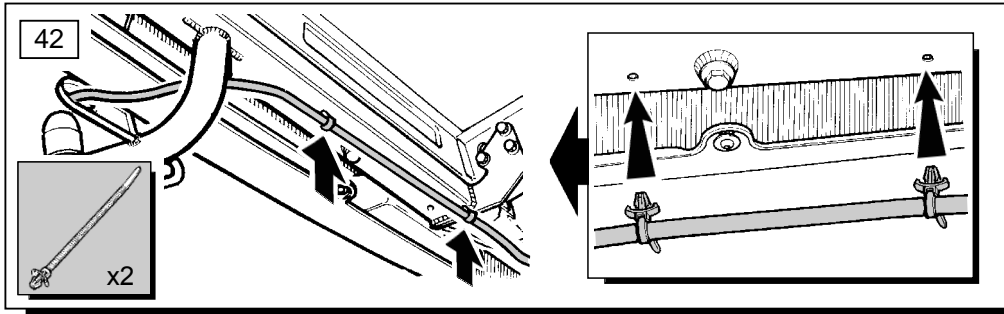
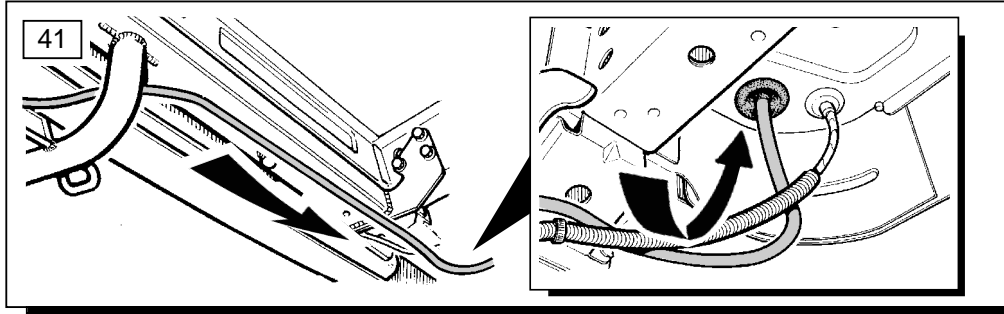
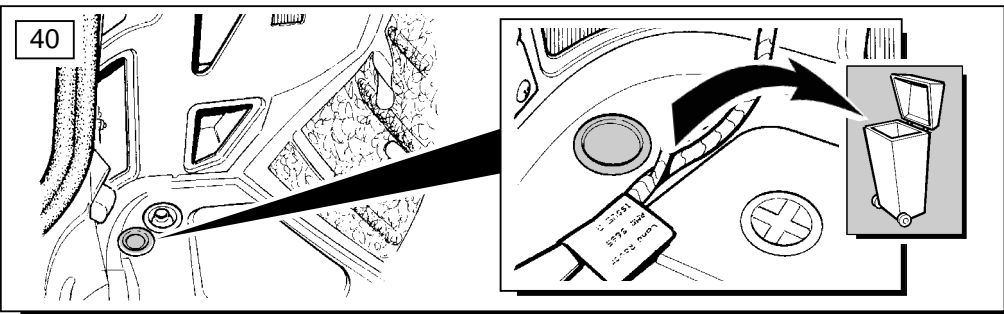
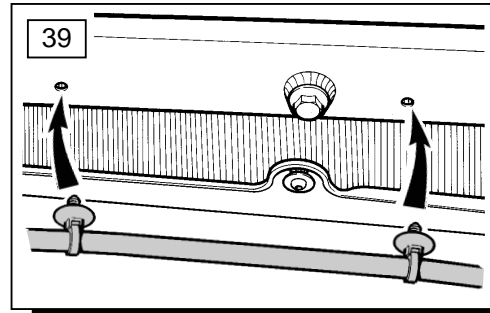
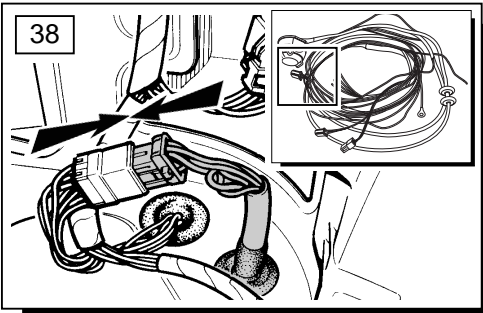
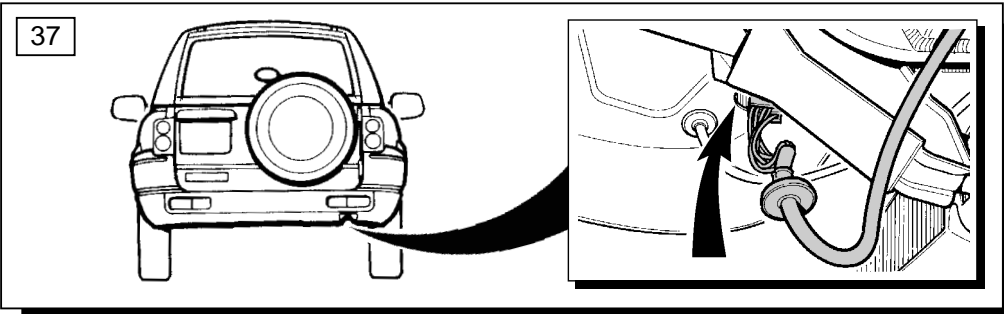
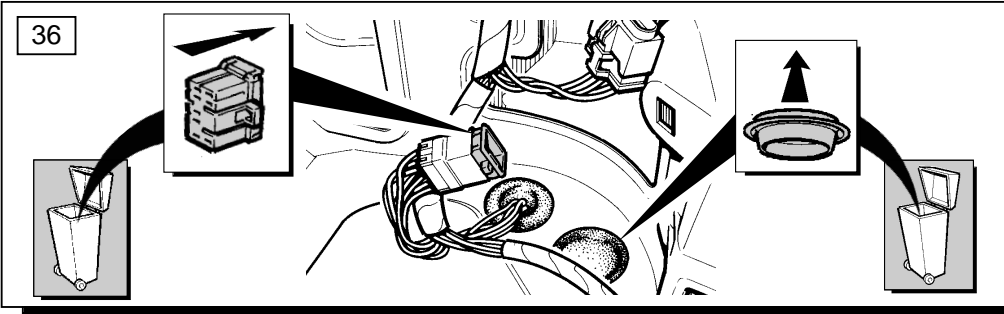



44

①	②	③	④
GB Red/White	Black	Yellow/White	Green/White
D Rot/Weiß	Schwarz	Gelb/Weiß	Grün/Weiß
F Rouge/Blanc	Noir	Jaune/Blanc	Vert/Blanc
I Rosse/Blanco	Negro	Giallo/Blanco	Vert/Blanco
E Rojo/Blanco	Nero	Amarillo/Blanco	Verde/Blanco
P Vermelho/Branco	Preta	Amarelo/Branco	Verde/Branco
NL Rood/Wit	Zwart	Geel/Wit	Groen/Wit
GR Κόκκινο/Λευκό	Μαύρο	Κίτρινο/Λευκό	Πράσινο/Λευκό
B レッド/ホワイト	ブラック	イエロー/ホワイト	グリーン/ホワイト



46

47

VIN < 4A0001

45 → 47

51 →

VIN > 4A0001

48 → 50

51 →

48

45

49

GB Green/Brown
D Grün/Braun
F Vert/Brun
I Verde/Bruno
E Verde/Marrón
P Verde/Marrom
NL Groen/Bruin
GR Πράσινο/Καφέ
B グリーン/茶色



50

- (GB) Green/Brown
- (D) Grün/Braun
- (F) Vert/Brun
- (I) Verde/Bruno
- (E) Verde/Marrón
- (P) Verde/Marrom
- (NL) Groen/Bruin
- (GR) Πράσινο/Καφέ
- (B) グリーン/ 茶色



- (GB) 3 Door Only
- (D) Nur 3-Tür.
- (F) 3 portes uniquement.
- (I) 3 porte solamente.
- (E) 3 puertas solamente.
- (P) Apenas 3 portas.
- (NL) Alleen drieurs.
- (GR) 3-πορτα μόνο
- (B) 3 ドアのみ

- (GB) Follow procedures 55 to 70 then 84 onwards.
- (D) Vorgänge 55 bis 70 und dann ab 84 durchführen.
- (F) Suivre les procédures de 55 à 70 puis à partir de 84.
- (I) Seguire la procedura da 55 a 70 e poi da 84 in avanti.
- (E) Seguir los procedimientos 55 hasta 70 y luego de 84 en adelante.
- (P) Siga os procedimentos 55 a 70 a, seguir de 84 em diante.
- (NL) Verricht handelingen 55 t/m 70 en vanaf 84.
- (GR) Ακολουθήστε τις διαδικασίες 55 έως 70 και κατόπιν από την 84 και μετά.
- (B) まず、55から70の手順に従い、その後84以降の手順に従います。

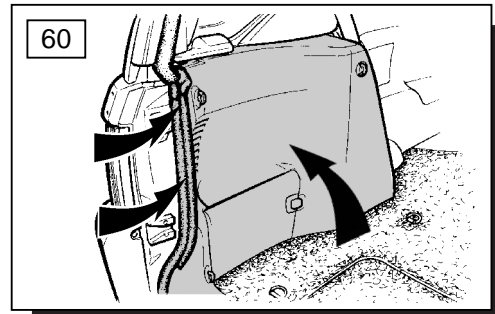
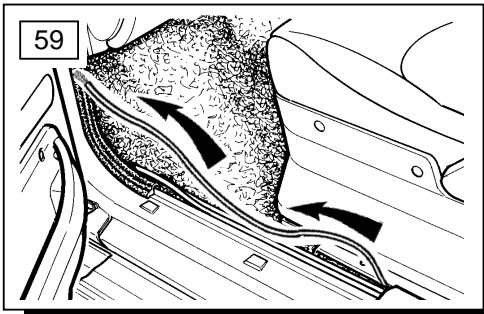
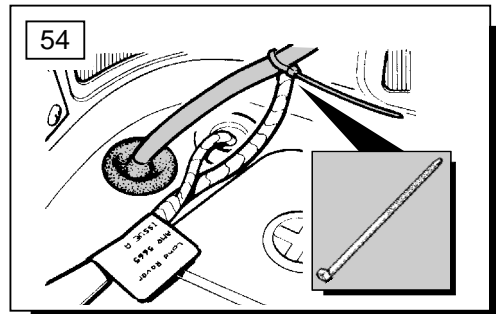
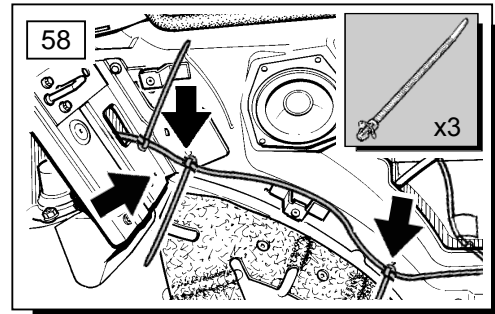
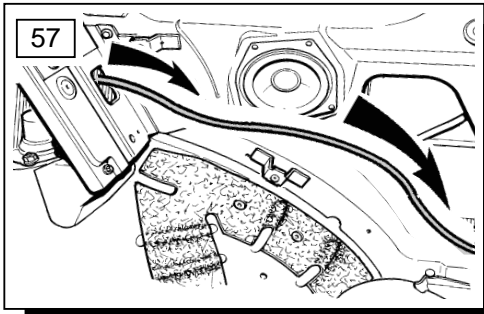
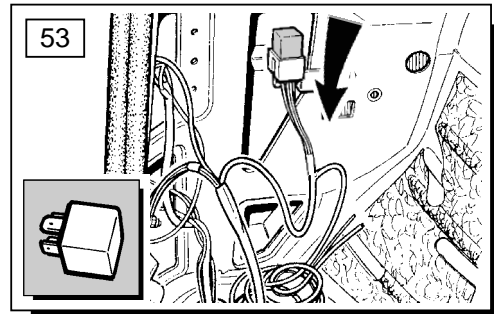
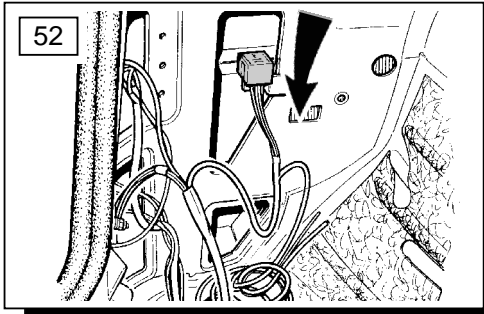
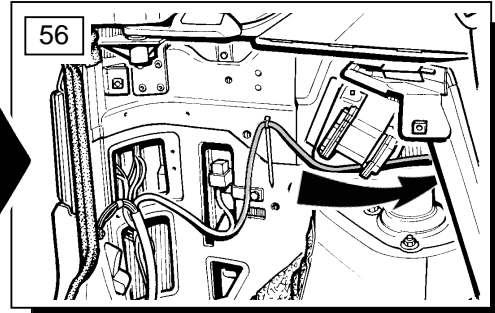
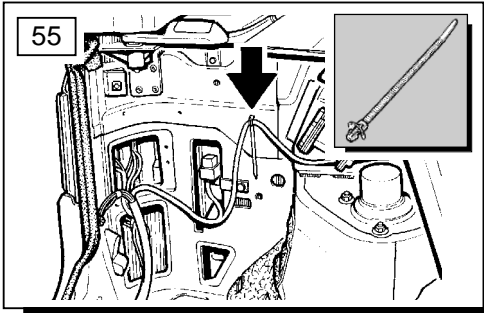
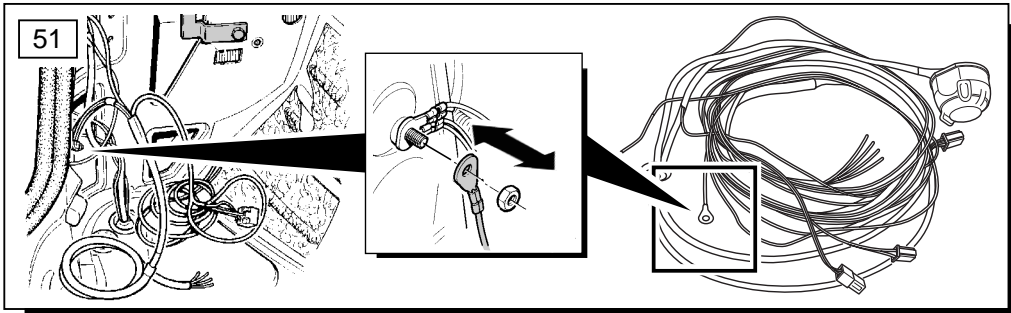

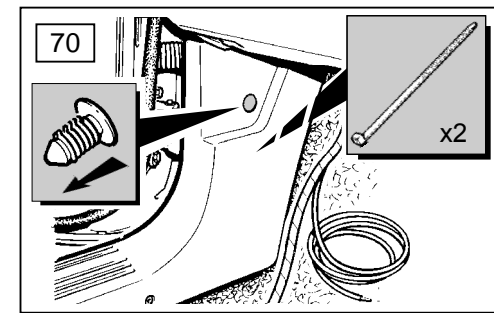
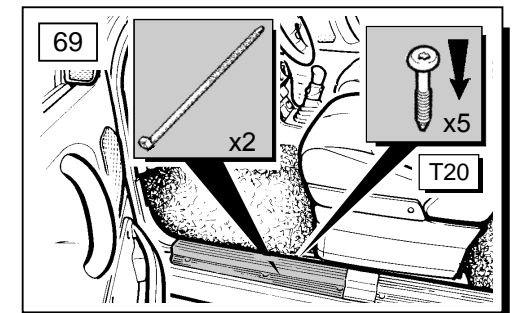
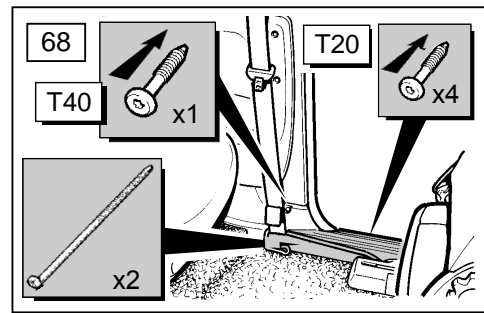
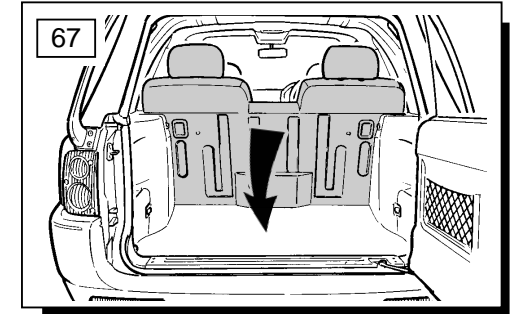
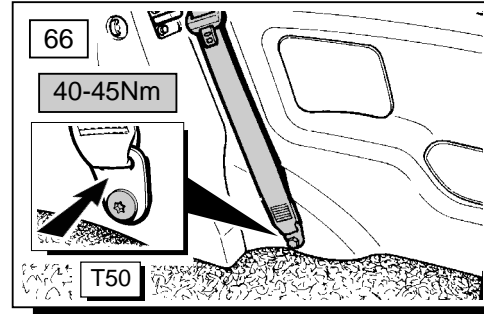
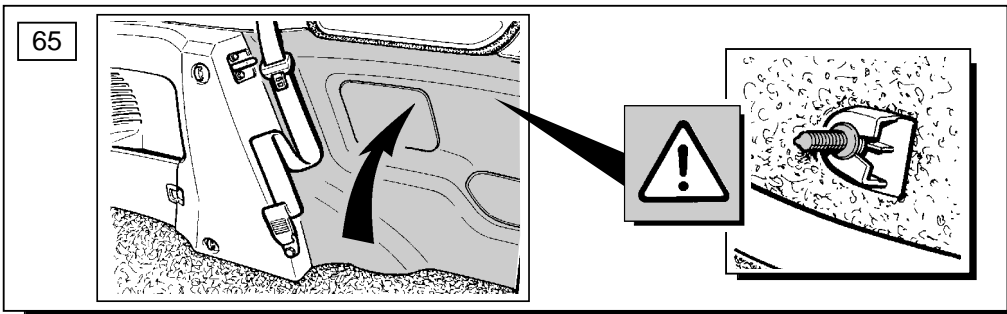
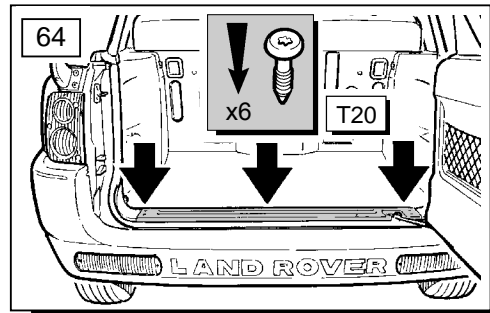
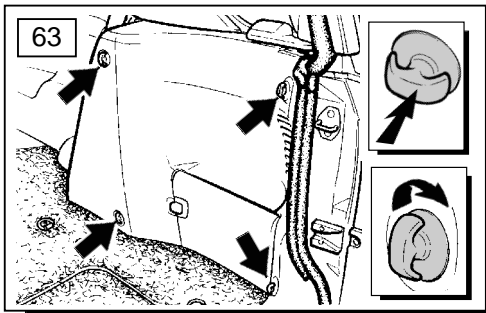
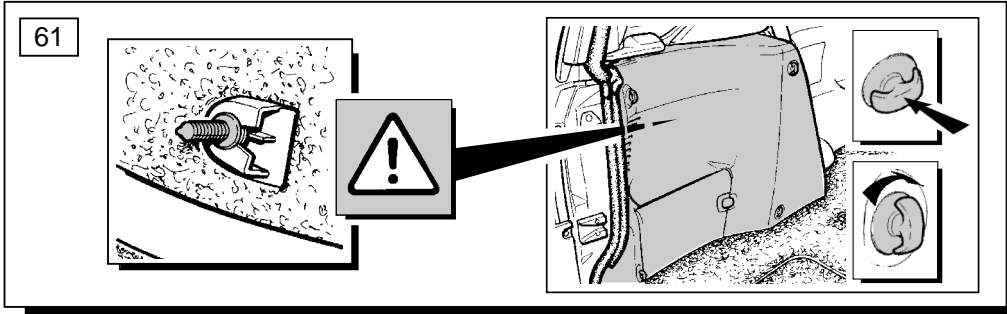

- (GB) 5 Door Only
- (D) Nur 5-Tür.
- (F) 5 portes uniquement.
- (I) 5 porte solamente.
- (E) 5 puertas solamente.
- (P) Apenas 5 portas.
- (NL) Alleen vijfdeurs.
- (GR) 5-πορτα μόνο
- (日) 5 ドアのみ

- (GB) Follow procedures 71 to 83 then 84 onwards.
- (D) Vorgänge 71 bis 83 und dann ab 84 durchführen.
- (F) Suivre les procédures de 71 à 83 puis à partir de 84.
- (I) Seguire le procedura da 71 a 83 e poi da 84 in avanti.
- (E) Seguir los procedimientos 71 hasta 83 y luego de 84 en adelante.
- (P) Siga os procedimentos 71 a 83 a, seguir de 84 em diante.
- (NL) Verricht handelingen 71 t/m 83 en vanaf 84.
- (GR) Ακολουθήστε τις διαδικασίες 71 έως 83 και κατόπιν από την 84 και μετά.
- (日) まず、71から83の手順に従い、その後84以降の手順に従います。

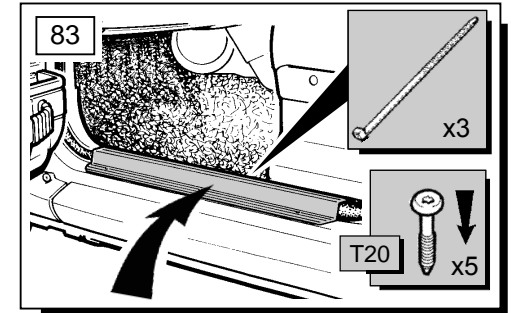
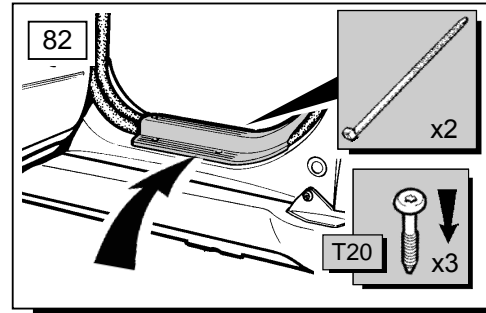
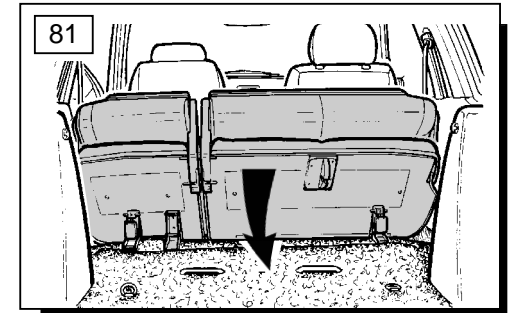
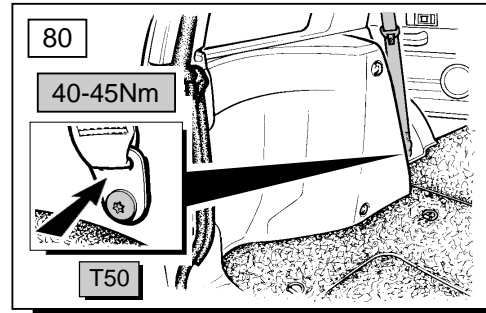
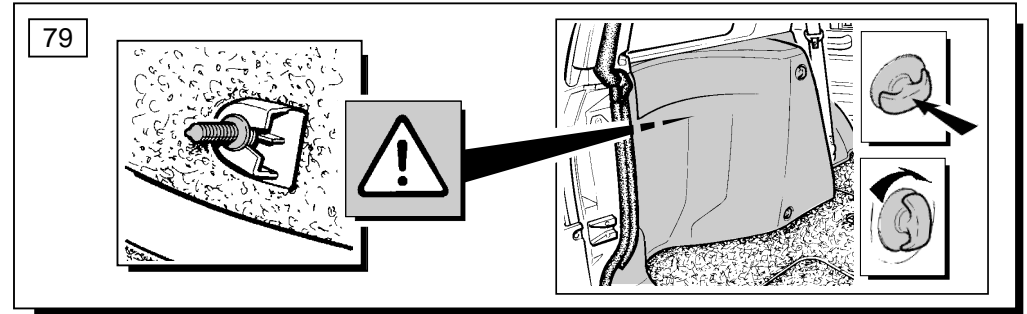
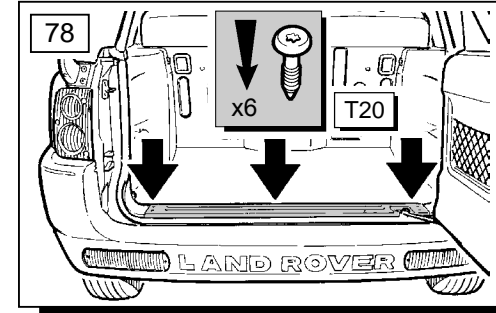
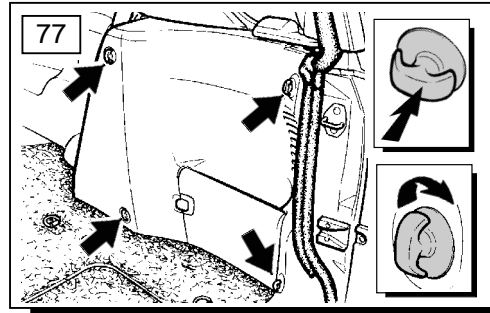
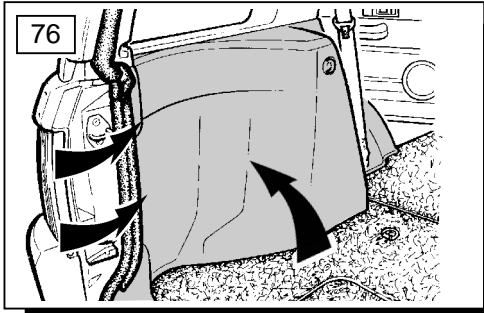
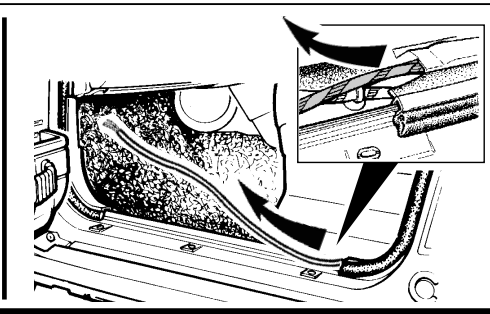
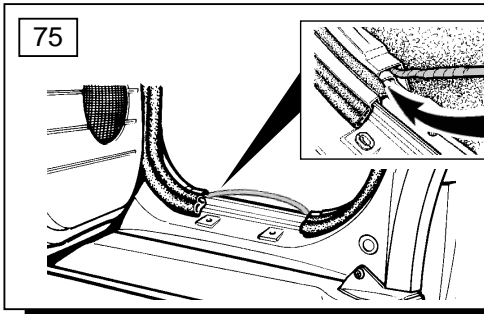
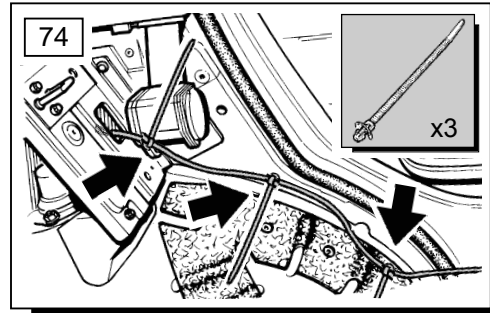
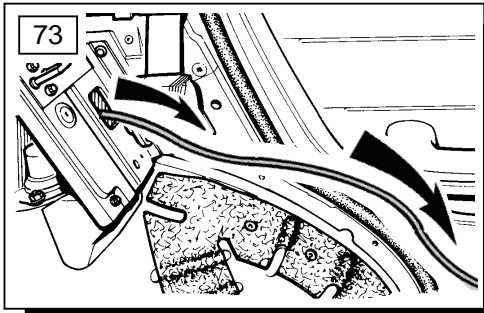
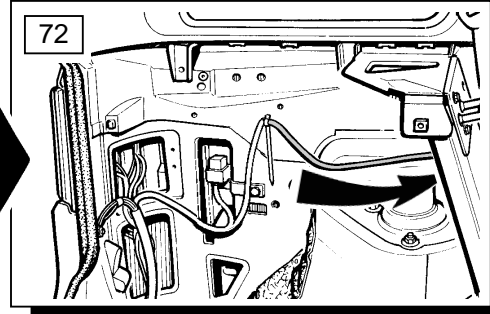
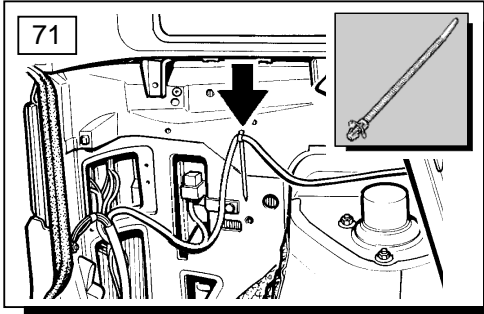

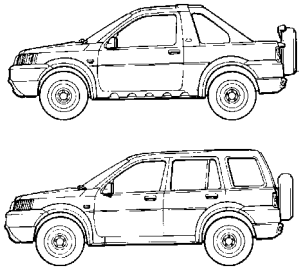

- GB** 3 and 5 door vehicles
- D** 3-türige und 5-türige Fahrzeuge
- F** Véhicule à trois et cinq portes
- I** Veicoli da 3 e 5 portiere.
- E** Vehículos de 3 y 5 puertas
- P** veículos de 3 e 5 portas
- NL** Drie- en vijfdeurs modellen
- GR** 3-πορτα και 5-πορτα οχήματα.
- 日** 3ドア車と5ドア車

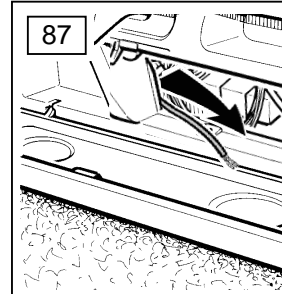

- GB** White/Green
- D** Weiß/Grün
- F** Blanc/Vert
- I** Bianco/Vert
- E** Blanco/Verde
- P** Branco/Verde
- NL** Wit/Groen
- GR** Άσπρο/Πράσινο
- 日** ホワイト/グリーン

84

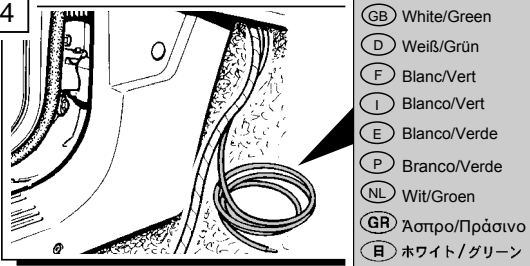

- GB** White/Green
- D** Weiß/Grün
- F** Blanc/Vert
- I** Bianco/Vert
- E** Blanco/Verde
- P** Branco/Verde
- NL** Wit/Groen
- GR** Άσπρο/Πράσινο
- 日** ホワイト/グリーン

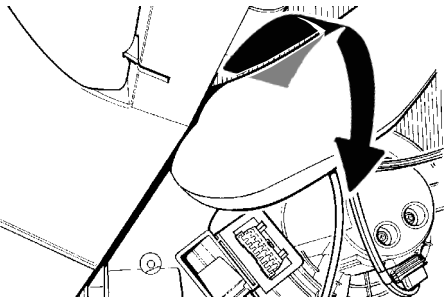
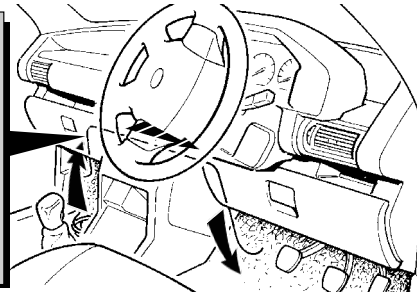

88

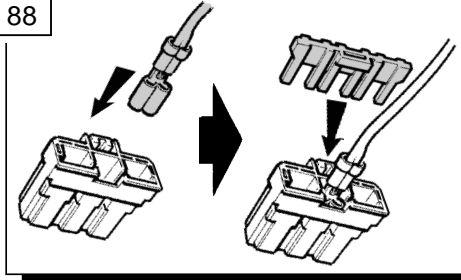

C594

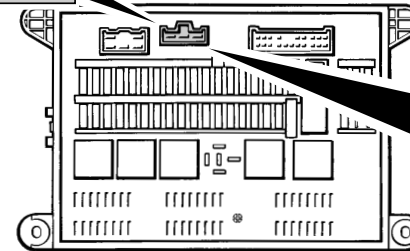

- GB** Brown to Cavity C594
- D** Braun in Öffnung C594
- F** Brun à cavité C594
- I** Filo marrone nella cavità C594
- E** Marrón a la cavidad C594
- P** Castanho na Cavidade C594
- NL** Bruin naar aansluitcontact C594
- GR** Καφέ στην Υποδοχή C594
- 日** 配線 (茶) を端子 C594 に挿入

85

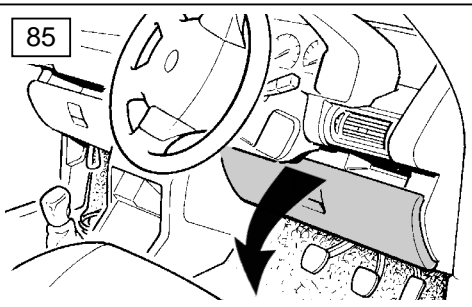

86

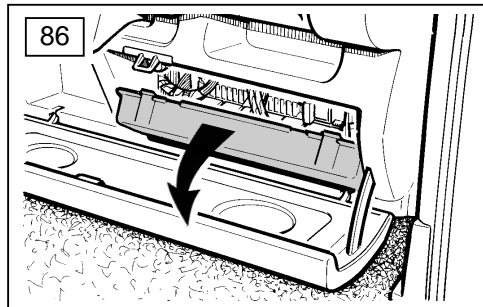

89

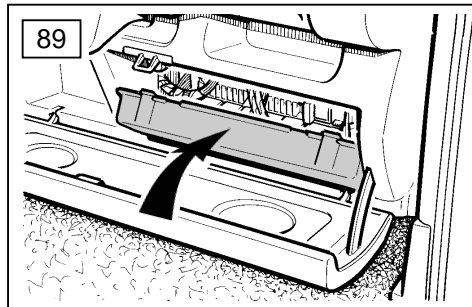

90

