



**LAND ROVER
ACCESSORIES**

WARNING

Accessories which are not properly fitted can be dangerous. Read the instructions carefully prior to fitting. Whilst fitting, comply with the instructions at all times. If in doubt, contact your nearest Land Rover Dealer.

ACHTUNG!

Nicht sahgemäß montiertes Zubehör kann gefährlich sein. Lesen Sie die Montageanleitung sorgfältig, bevor Sie das Teil montieren. Halten Sie sich bei der Montage an die Anleitung. Bei Unsicherheiten wenden Sie sich bitte an Ihren Land Rover Händler.

AVERTISSEMENT

Les accessoires qui ne sont pas correctement montés risquent d'être dangereux. Veuillez lire soigneusement les instructions avant d'effectuer la pose. Respectez toujours les instructions en cours de pose. En cas de doute, consultez votre concessionnaire Land Rover local.

AVVERTENZA

Gli accessori non sistemati come previsto possono essere pericolosi. Leggere attentamente le istruzioni prima del fissaggio. Durante il montaggio seguire sempre le relative istruzioni. In caso di dubbio rivolgersi al più vicino concessionario della Land Rover.

AVISO

Aquellos accesorios que no hayan sido ajustados debidamente pueden resultar peligrosos. Lea las instrucciones antes de iniciar el montaje. Durante el montaje siga las instrucciones en todo momento. En caso de duda póngase en contacto con su Concesionario de Land Rover.

ADVERTÊNCIA!

Os Acessórios que não são montados adequadamente podem ser perigosos. Leia as instruções cuidadosamente antes de montar. Durante a montagem obedeça as instruções todo o tempo. Se tiver alguma dúvida, contacte o Concessionário Land Rover mais próximo.

WAARSCHUWING

Accessoires die niet op de juiste wijze zijn gemonteerd kunnen gevaar opleveren. Lees de instructies zorgvuldig door eer met de montage wordt begonnen. Tijdens de montage altijd de instructies in acht nemen. Bij twijfel contact opnemen met de dichtstbijzijnde Land Rover dealer.

ΠΡΟΕΙΔΟΠΟΙΗΣΗ

Τα προαιρετικά εξαρτήματα που δεν έχουν τοποθετηθεί σωστά μπορεί να είναι επικίνδυνα. Διαβάστε τις οδηγίες πριν προχωρήσετε στην τοποθέτησή τους. Κατά την τοποθέτηση τηρείτε συνεχώς τις οδηγίες. Αν έχετε οποιαδήποτε αμφιβολία, επικοινωνήστε με τον πλησιέστερο αντιπρόσωπο της Land Rover.



**LAND ROVER
ACCESSORIES**

FITTING INSTRUCTION

Air Conditioning Kit – Diesel

EINBAUANLEITUNG

Klimaanlagen-Einbausatz – Diesel

INSTRUCTION DE MONTAGE

Kit de Climatisation – Diesel

ISTRUZIONI PER IL MONTAGGIO

Corredo condizionamento aria – Diesel

INSTRUCCIONES DE MONTAJE

Kit de aire acondicionado – Diesel

INSTRUÇÕES DE MONTAGEM

Kit de Ar Condicionado – Motores a Gasóleo

MONTAGEHANDLEIDING

Air-conditioning set, dieselmotoren

ΟΔΗΓΙΕΣ ΤΟΠΟΘΕΤΗΣΗΣ

Κιτ Συστήματος Κλιματισμού
– Για Κινητήρες Πετρελαίου (Diesel)

LAND ROVER ACCESSORIES



Important Information

This installation manual is in 8 language sections.

ENGLISH Page 5



Wichtige Information

Dieses Installationshandbuch ist in 8 Abschnitte in je einer Sprache unterteilt.

DEUTSCH Page 33



Information importante

Ce manuel d'installation est rédigé en 8 langues.

FRANCAIS Page 61



Informazioni importanti

Questo manuale d'installazione è suddiviso in 8 capitoli, ciascuno in una lingua differente.

ITALIANO Pagina 89



Información importante

Este manual de instalación está dividido en 8 secciones de idiomas.

ESPAÑOL Página 117



Informação Importante

Este manual de instalação está dividido em 8 secções, em função da língua.

PORTUGUÊSPágina 145



Belangrijke informatie

Deze installatiehandleiding is in 8 talen.

NEDERLANDSPagina 173



Σημαντικές Πληροφορίες

Το παρόν χειρίδιο εγκατάστασης περιέχει 8 γλώσσες.

ΕΛΛΗΝΙΚΑΣελίδα 201



CONTENTS

• INTRODUCTION	6
• TORQUE SETTINGS	6
• KIT CONTENT	7
• PRECAUTIONS	8
• AIR BAG PRECAUTIONS	9
• SYSTEM LAYOUT	9
• INTERIOR	
Centre Console Removal	10
Steering Wheel Removal	12
Column Switch Assembly	12
Facia Panel Removal	13
Facia Panel - Switches	14
Facia Panel - Electrical Connections	15
• ENGINE BAY	
Engine Bay Preparation	18
Heater Unit Removal	19
Condenser	19
New A/C Harness - Interior Connections	20
Drive Belt	22
Compressor	22
Pipes and Hoses	23
New A/C Harness - Engine Bay Connections	26
Engine Bay Refit.....	28
• CHARGING THE SYSTEM	
General Precautions.....	29
Remedial Actions	29
Servicing Equipment.....	30
Charging	30
Leak Test System	30
Performance Test	31



INTRODUCTION

This air conditioning fitting instruction applies to vehicles produced from 1998 model year only.

This manual is designed to assist skilled technicians. Individuals who undertake their own fitment should have some skill/training and do so at their own risk.

REFERENCES

References to the left or right hand side in the manual are made when viewing the vehicle from the driving position.

This fitting instruction is for use with left hand and right hand drive vehicles.

Instructions are valid for both types of vehicle unless otherwise stated.

Illustrations do not conform to either drive and vary throughout this manual.

It is essential that work is inspected and tested after completion and if necessary a road test of the vehicle is carried out.

IMPORTANT NOTICES

WARNINGS, CAUTIONS and NOTES are given throughout this Manual in the following form:

WARNING:
Procedures which must be followed precisely to avoid the possibility of personal injury.

CAUTION:
This calls attention to procedures which must be followed to avoid damage to components.

NOTE:
This calls attention to methods which make a job easier or gives helpful information.

TORQUE SETTINGS

Torque wrenches should be regularly checked for accuracy to ensure that all fixings are tightened to the correct torque.

METRIC	Nm
M5	6
M6	9
M8	25
M1	45
M12	90
M14	105
M16	180

UNC/UNF	Nm
1/4	9
5/16	24
3/8	39
7/16	78
1/2	90
5/8	136

Torque values above are for all screws and bolts used, except for those that are specified otherwise.

COPYRIGHT

© Land Rover 1998
All rights reserved. No part of this publication may be produced, stored in a retrieval system or transmitted in any form, electronic, mechanical, recording or other means without prior written permission of Land Rover.



KIT CONTENT

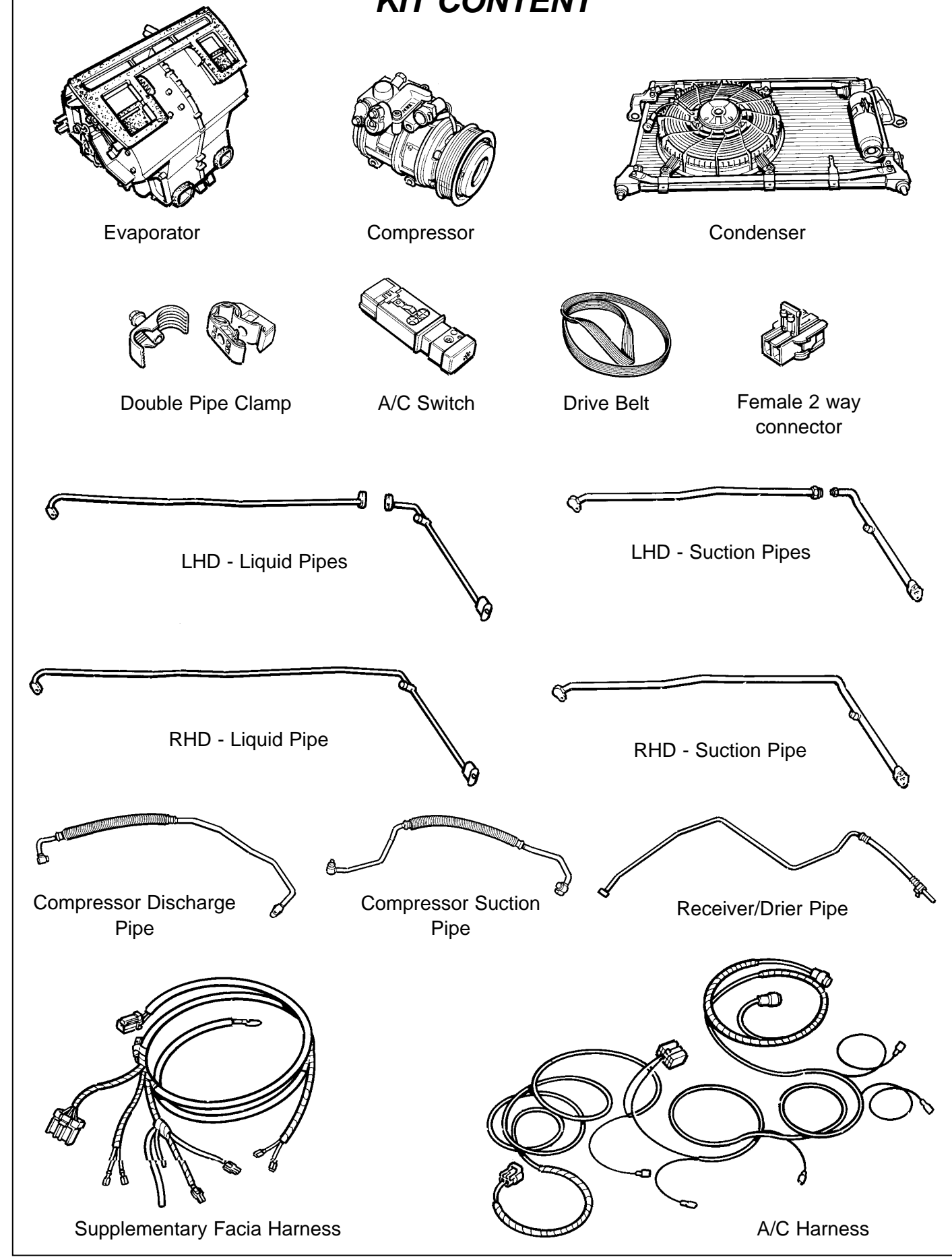



PRECAUTIONS IN HANDLING REFRIGERANT PIPES

WARNING:

Wear eye and hand protection when disconnecting components containing refrigerant. Plug all exposed connections.

- 1 Charging or discharging the A/C system must only be carried out by qualified personnel that are familiar with the charging and recovery equipment. Refer to the workshop manual for charging procedure.
- 2 When disconnecting any hose or pipe connection, the system must be discharged of all pressure. Proceed cautiously, regardless of gauge readings. Open connections slowly, keeping hands and face well clear, so that no injury occurs if there is liquid in the pipe. If pressure is noticed, allow it to bleed off slowly.
- 3 Pipes, flexible end connections and components must be capped immediately they are opened to prevent the entrance of moisture and dirt.
- 4 Any dirt or grease on fittings must be wiped off with a clean alcohol dampened cloth. Do not use chlorinated solvents such as Trichloroethylene. If dirt, grease or moisture cannot be removed from inside the hoses, they must be replaced with new hoses.
- 5 All replacement components and flexible end connections must be sealed, and only opened immediately prior to making the connection.
- 6 Ensure the components are at room temperature before uncapping, to prevent condensation of moisture from the air that enters.
- 7 Components must not remain uncapped for longer than fifteen minutes. In the event of delay, the caps must be fitted.
- 8 Receiver/drier must never be left uncapped as it contains zeolite which will absorb moisture from the atmosphere. A receiver/drier left uncapped must not be used, fit a new unit.
- 9 The compressor shaft must not be rotated until the system is entirely assembled and contains a charge of refrigerant.
- 10 A new compressor contains the correct charge of refrigerant oil for the complete system. The compressor also contains a holding charge of gas when received, which should be retained until the pipes are re-connected.
- 11 The receiver/drier should be the last component connected to the system to ensure optimum dehydration and maximum moisture protection of the system.
- 12 All precautions must be taken to prevent damage to fittings and connections. Slight damage could cause a leak with the high pressures used in the system.
- 13 Always use two spanners of the correct size, one on each fitting when releasing and tightening refrigeration unions.
- 14 Joints and 'O' rings should be coated with refrigeration oil to aid correct seating. Fittings which are not lubricated with refrigerant oil are almost certain to leak.
- 15 All pipes must be free of kinks. The efficiency of the system is reduced by a single kink or restriction.
- 16 Flexible hoses should not be bent to be a radius less than 90mm radius.
- 17 Flexible hoses should not be within 100mm of the exhaust manifold.
- 18 Completed assemblies must be checked for refrigeration pipes touching metal panels. Any direct contact of lines and panels transmits noise and must be eliminated.



AIR BAG REMOVAL

The removal of vehicle air bags are only to be carried out by qualified personnel at Authorised Land Rover Dealerships. Individuals undertaking such tasks do so at their own risk.

WARNING:

Unauthorised tampering of air bags may cause the unit to fail and will affect the warranty.

AIR BAG STORAGE

Refer to workshop manual.

Air bag modules are classed as an explosive and as such they must be stored in an approved secure steel cabinet which has been certified by the local authority of fire department.

WARNING:

If the air bag is improperly stored face down, accidental deployment could propel the unit with enough force to cause serious injury.

AIR BAG PRECAUTIONS

Carefully inspect all air bag parts before re-installing. Do not install any part that shows signs of being dropped or improperly handled, such as dents, cracks or deformation.

CAUTION:

The air bag system has sufficient stored energy to deploy air bags for up to 20 minutes.

DO NOT cut the air bag module wiring, enclosed in a **YELLOW** sheath.

DO NOT use electrical test equipment on the air bag harness or connectors. Tampering with or disconnecting the harness could result in accidental firing of the air bag or make the system inoperative, which may result in serious injury.

DO NOT try to dismantle the air bag module. The air bag module contains Sodium Azide which is poisonous and extremely flammable. Contact with water, acid or heavy metals may produce harmful or explosive compounds. Do not bring into contact with electricity.

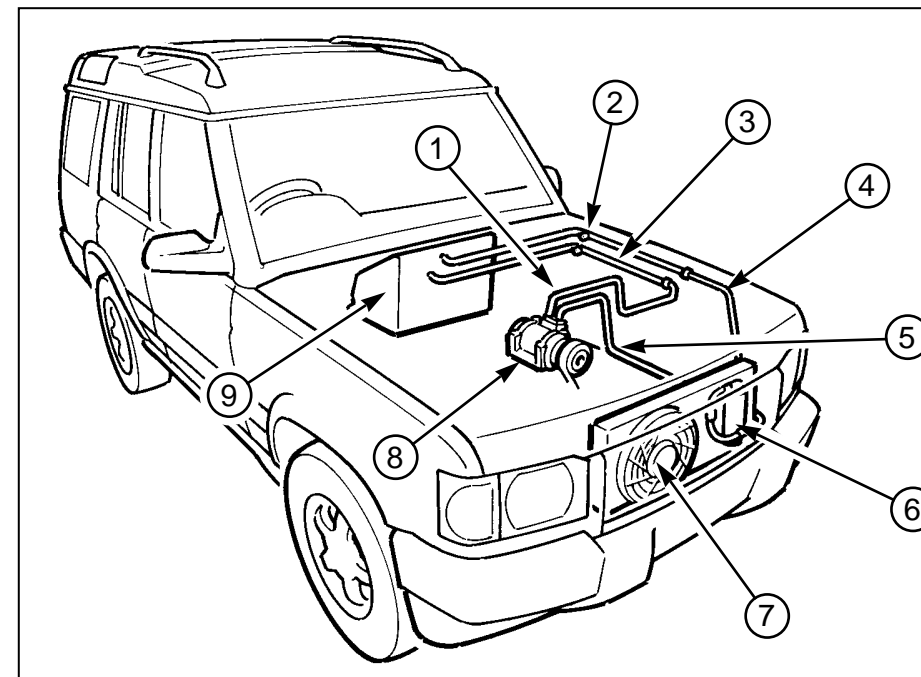

SYSTEM LAYOUT

- 1 Compressor pipe
- 2 Liquid Pipe
- 3 Suction Pipe
- 4 Receiver/Drier pipe
- 5 Discharge pipe
- 6 Receiver/drier
- 7 Condenser
- 8 Compressor
- 9 Evaporator

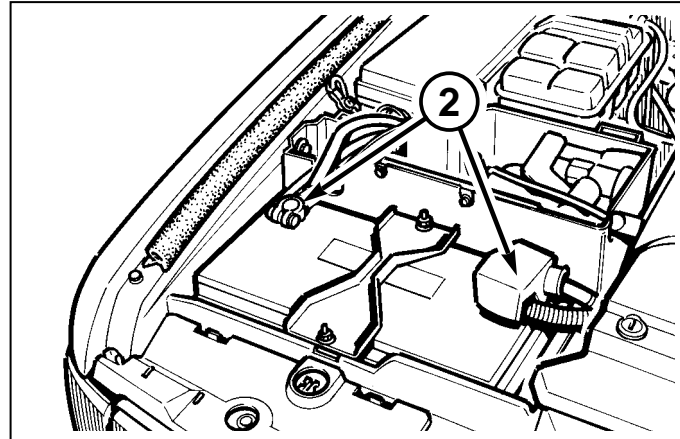

INTERIOR PREPARATION

CENTRE CONSOLE - Removal

- 1 Refer to workshop manual for alarm immobilisation.
Prior to disconnecting the battery note the security code and station settings of the radio.
- 2 Remove battery cover and disconnect the battery cables. (Disconnect the negative cable first).
- 3 Release gaiter and unscrew transfer gear lever knob.

Automatic:

- 4 Lift vertically and disengage gear selector finisher panel from console.
- 5 With a sharp vertical pull, remove gearshift lever and sleeve.

NOTE:

To avoid damage ensure the gear shift lever is pulled vertically.

- 6 Disconnect connector and remove gear selector finisher panel.

Manual:

- 7 Release gaiter from gear lever and pull up over gear knob.
- 8 Remove M8 bolt and remove gear lever.

All Vehicles:

- 9 Remove window switch panel finisher.
- 10 Remove and retain four Phillips screws securing window switch panel.
- 11 It is unnecessary to remove the switch panel. When removing the console pass the switch panel back through its aperture.

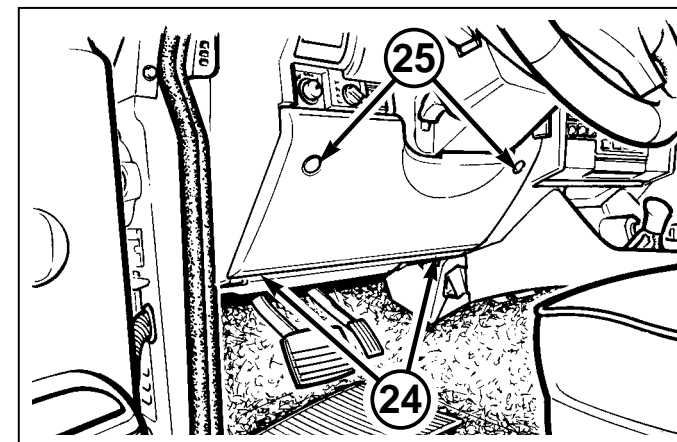
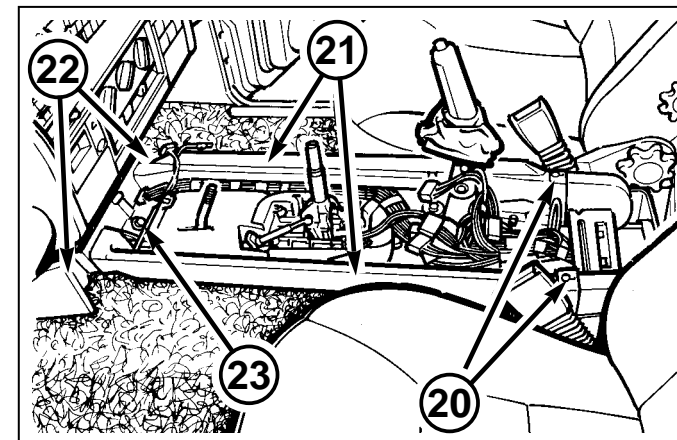
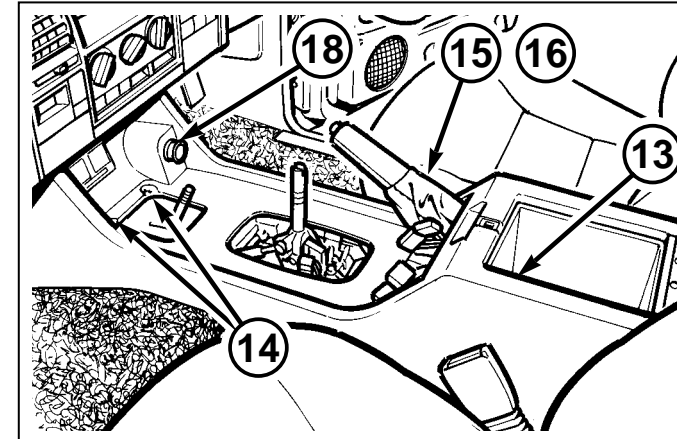
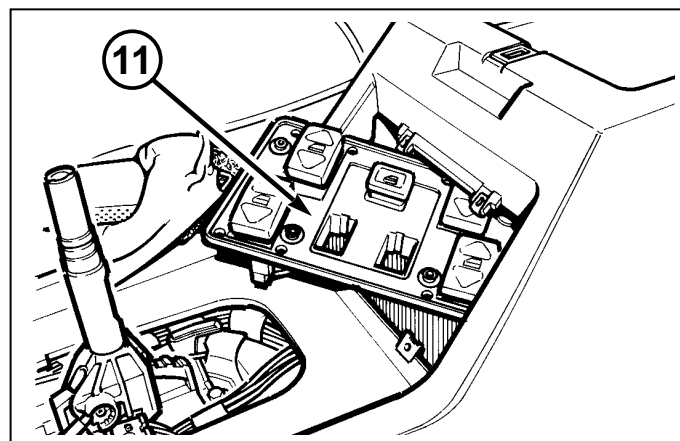
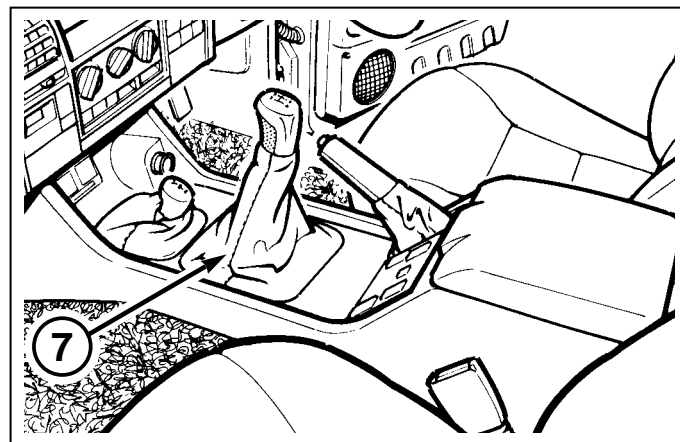
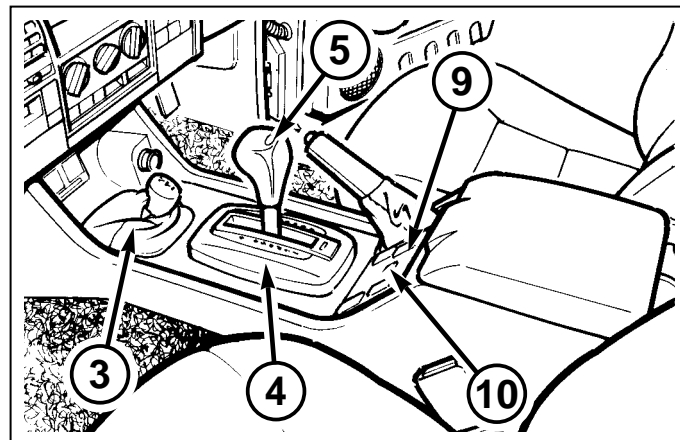

- 12 Remove rubber mat from centre console.
- 13 Open centre console glove box, remove and retain 2 M6 screws.
- 14 Remove and retain the remaining 2 M6 screws at the front of the console.
- 15 Release handbrake gaiter from console.
- 16 Remove the clip and clevis pin securing cable to hand brake.
- 17 Lift handbrake lever to vertical position and manoeuvre console slightly away from tunnel.
- 18 Disconnect Lucar connector and bulb from cigar lighter.
- 19 Lift console assembly over handbrake and gear levers, and remove from vehicle.
- 20 Remove and retain 2 Phillips screws securing rear heater ducts.
- 21 Remove and retain intermediate heater ducts.
- 22 Remove and retain footwell heater ducts and clips.
- 23 Remove and retain 2 Phillips screws securing console mounting bracket in front of transfer lever.
- 24 Remove and retain 4 M5 screws securing drivers closing panel.
- 25 Release turnbuckles and remove drivers closing panel from vehicle.
- 26 Position steering wheel so the road wheels are in the straight ahead position.

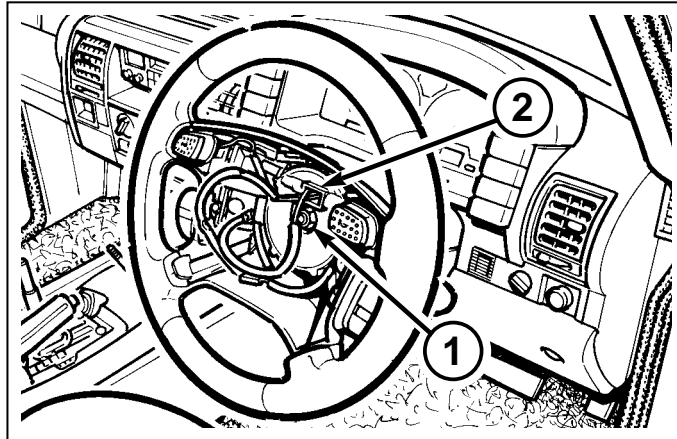
**STEERING WHEEL – Removal**

Steering wheel air bags must only be removed/installed by Authorised Land Rover personnel.

- 1 With the air bag removed, slacken the steering wheel nut to mid position and release steering wheel from its splines.
- 2 Disconnect Black connector from steering Wheel.
- 3 Remove nut and feed harness through aperture whilst removing steering wheel.

NOTE:

Place a piece of adhesive tape around the rotary coupler (A) to prevent rotation. Failure to do this may result in damage to the tape inside the coupler.

COLUMN SWITCH ASSEMBLY

- 4 Remove and retain three screws securing steering column shroud.
- 5 Remove and retain upper & lower steering column shroud.
- 6 Disconnect White six-way connector.
- 7 Disconnect Air bag connector in dash.
- 8 Release 2 clips securing rotary coupler to column.
- 9 Remove rotary coupler.
- 10 Slacken the Phillips screw securing the column switch assembly, and remove from steering column.
- 11 Disconnect 4 connectors from column switch assembly.
- 12 Refit steering column nut for protection.

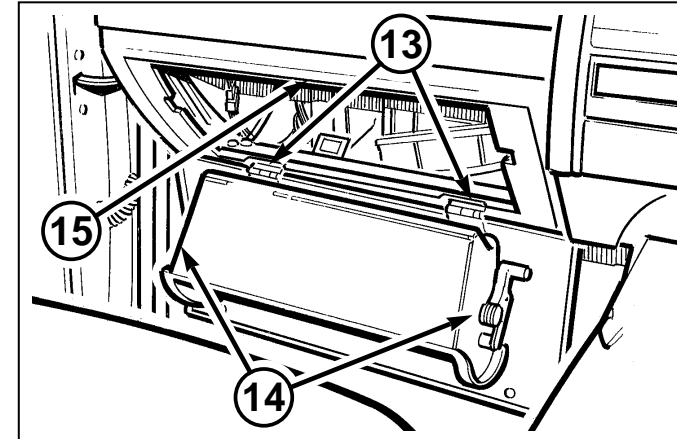
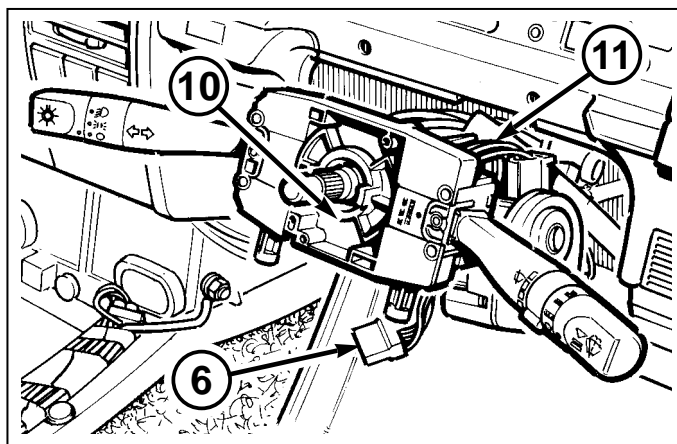
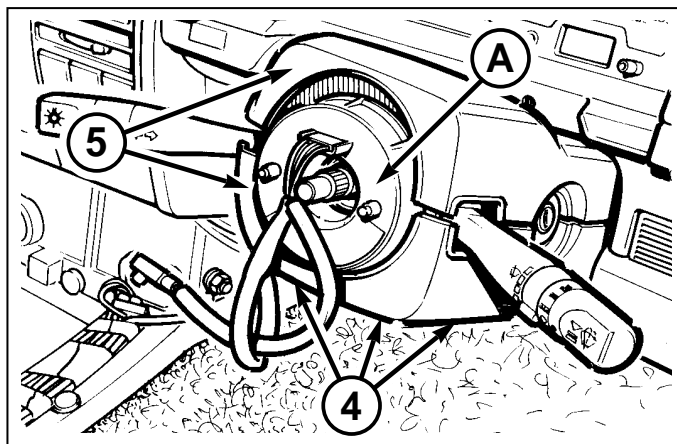
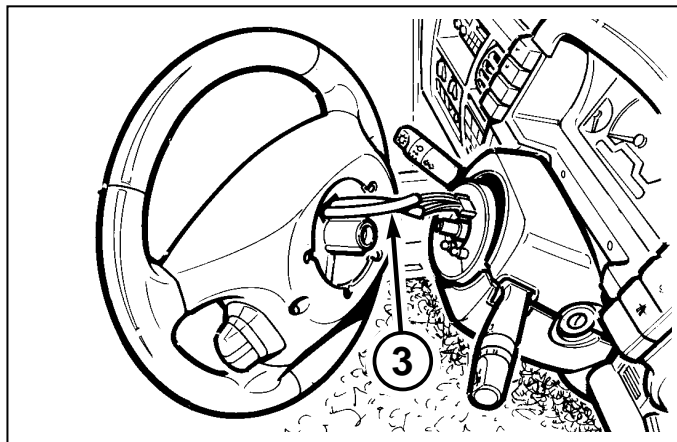
**FACIA PANEL – Removal**

Facia air bags must only be removed/installed by Authorised Land Rover personnel.

- 13 With Air bag removed, remove 4 M5 screws securing passenger's glovebox.
- 14 Release passenger's glove box by unclipping two spring retainers and remove.
- 15 Remove and retain 4 M8 facia mounting bolts from inside the passenger's glovebox housing.
- 16 Rotate all heater control knobs fully clockwise.
- 17 Unclip heater control cable(s) located on the left side of the heater box.

NOTE:

*LHD vehicles 2 cables.
RHD vehicles 1 cable.*

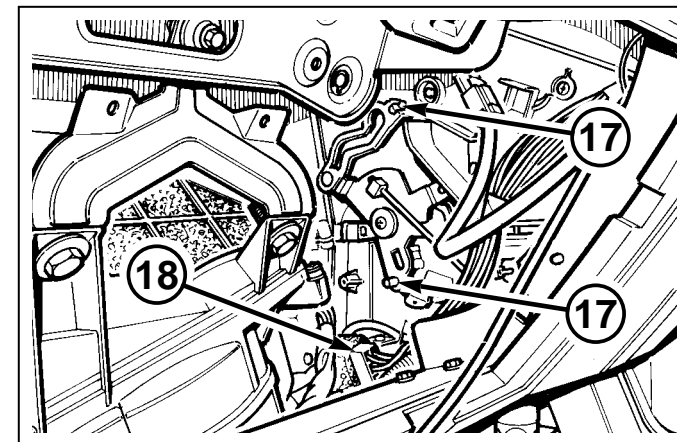

- 18 Disconnect 8 way heater box connector located on the passenger's side of heater box.
- 19 Remove passenger's lower glove box panel – 4 Fir Tree fixings.
- 20 Remove passenger's side kick panel – 2 Fir Tree fixings.
- 21 Remove passenger's facia mounting bracket (outboard) by removing and retaining 4 M8 bolts.
- 22 Remove passenger's facia mounting bracket (inboard) by removing and retaining 2 M8 nuts and 2 M8 bolts.

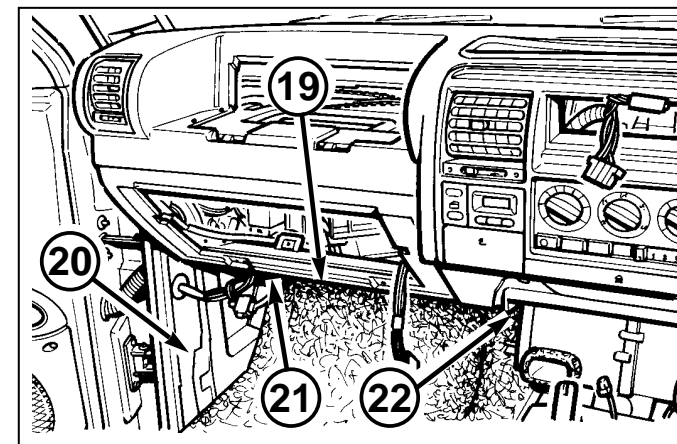

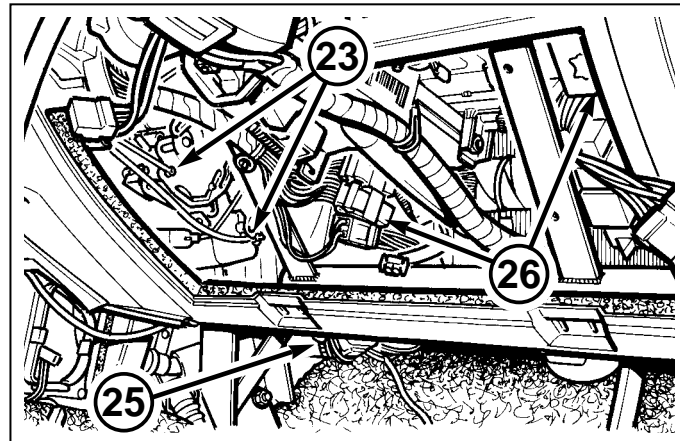

- 23 Unclip the heater control cable(s) located on the right side of the heater box.
NOTE:
LHD vehicles 1 cable.
RHD vehicles 2 cables.

- 24 Remove driver's lower fuse box panel.
- 25 Disconnect diagnostic connector.
- 26 Disconnect 2 fusebox electrical connectors and 3 main harness connectors located on the inboard side of the drivers lower dash panel.

- 27 Remove radio from facia.
- 28 Remove driver's side kick panel by removing Fir Tree fixing.
- 29 Remove driver's facia mounting bracket (outboard) by removing and retaining 4 M8 bolts.
- 30 Remove driver's facia mounting bracket (inboard) by removing and retaining 2 M8 nuts and 3 M8 bolts.
- 31 Remove and retain 4 M5 nuts and washers securing the facia to the steering mounting bracket.

NOTE:
Carefully remove facia from vehicle, check that all electrical connectors have been disconnected.

FACIA PANEL - SWITCHES

- 32 Remove the fan speed knob.
- 33 Remove the 3 heater control knobs.
- 34 Remove heater controls finisher panel – 2 Phillips screws.
- 35 From the rear push out the blank centre push-button switch and discard.
- 36 Insert new air conditioning push button switch (supplied in kit).
- 37 Refit all knobs and switches and check function.
- 38 Return all heater control knobs fully to the clockwise position.

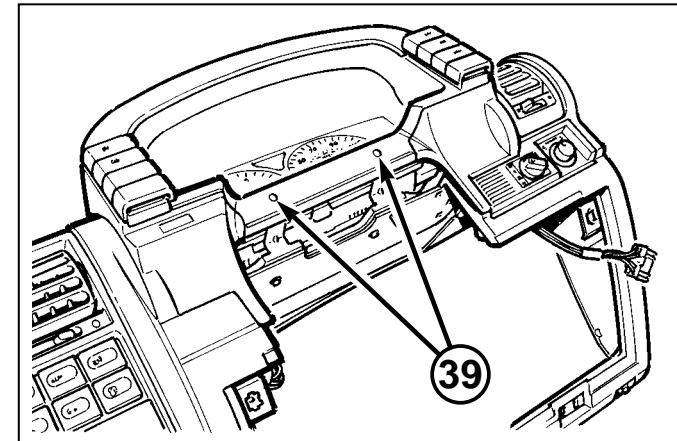
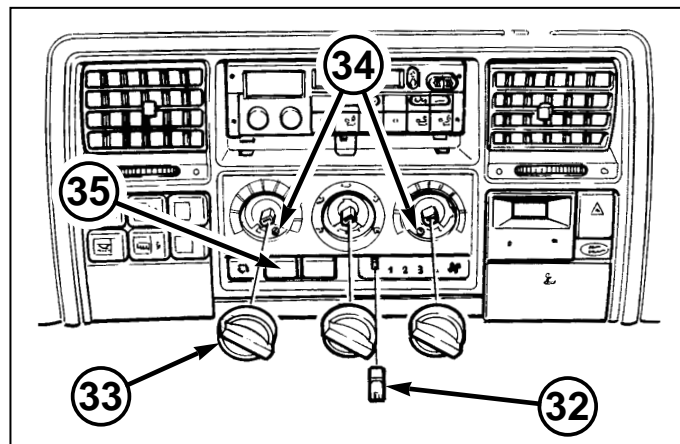
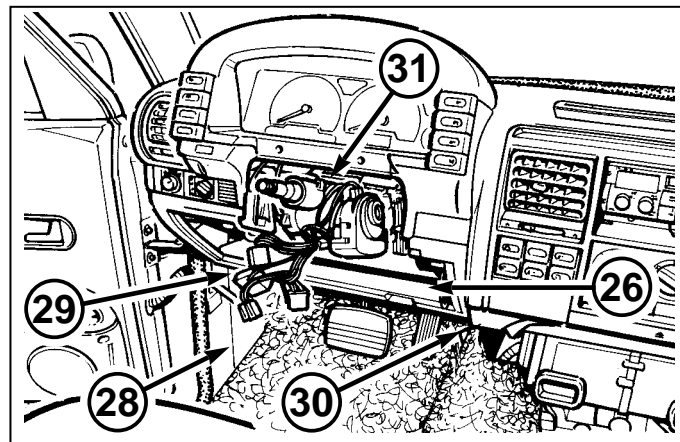

**FACIA PANEL
BINNACLE & INSTRUMENT PACK
REMOVAL**

- 39 Remove 2 screws securing binnacle.
- 40 Disengage clips at rear, lift binnacle clear and disconnect electrical connectors.
- 41 Remove 4 screws securing Instrument pack
- 42 Disconnect electrical connectors and remove instrument pack.
- 43 Cut the tiewrap securing Header Connector No.16 and feed it back through the harness aperture.

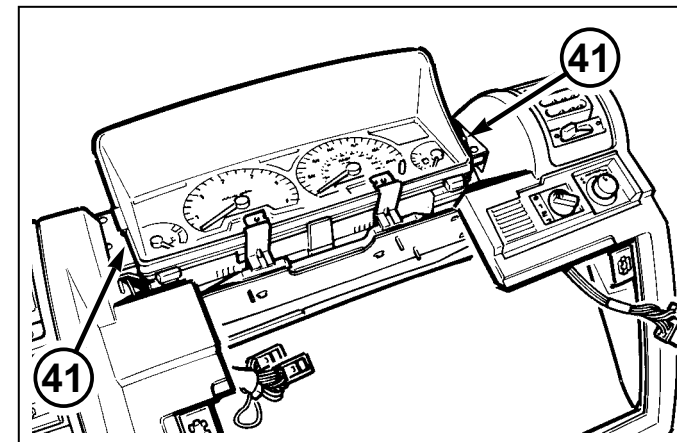

**SUPPLEMENTARY
FACIA HARNESS**

- 1 Locate white 5 way A/C switch connector on the Supplementary Facia Harness (supplied in kit) and connect to the previously fitted A/C Switch.

Header Connector

- 2 Locate the single Red/Brown wire on the Supplementary Facia Harness and insert into cavity 10 in the header connector.
- 3 Feed the header connector back through the harness aperture, reposition and secure with a tiewrap.

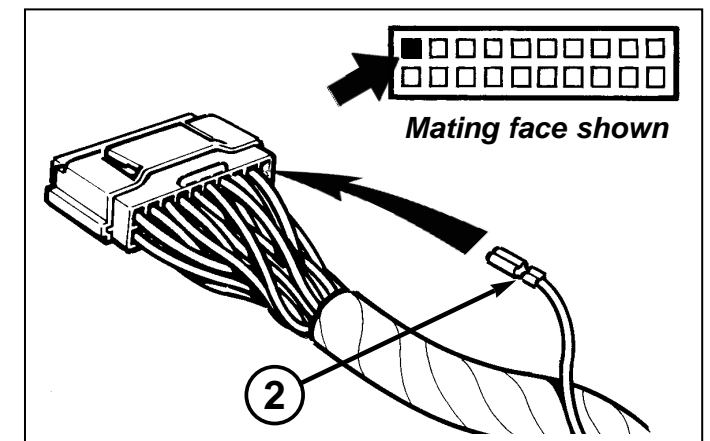
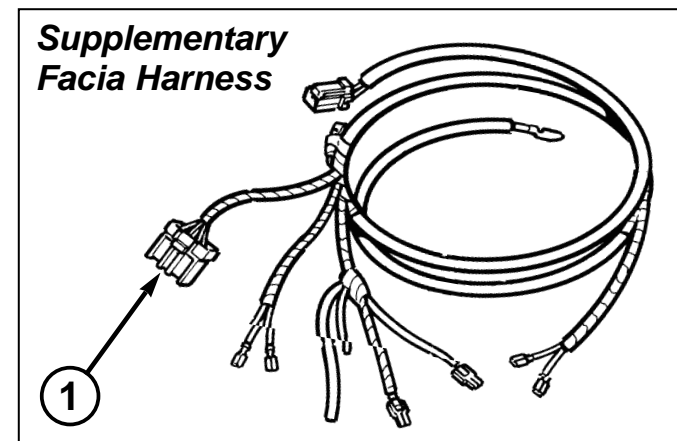
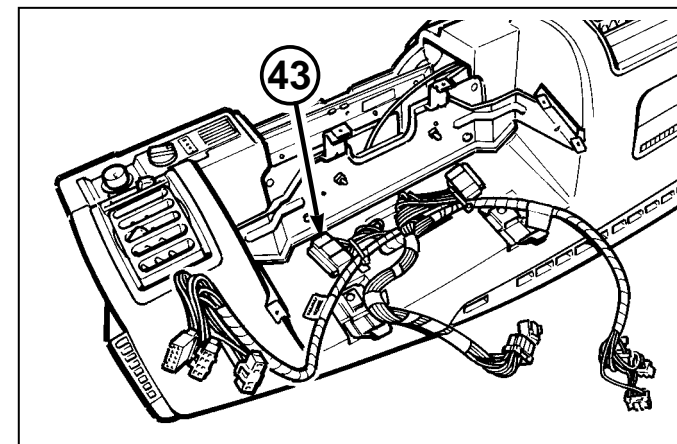

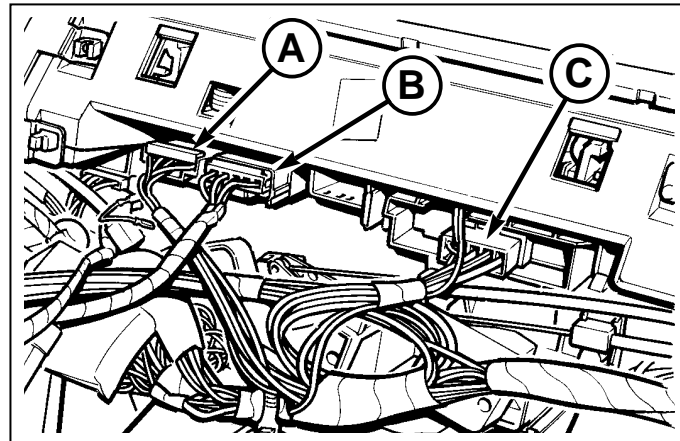

SUPPLEMENTARY FACIA HARNESS

- A - Recirculation Switch connector
- B - A/C Switch connector
- C - Blower Motor connector

Blower Motor Connector

- 4 Remove the connector from the blower motor switch (C) and release the anti-backout.
- 5 Carefully remove the Brown wire in cavity 1.
- 6 Locate the female 2 way plastic connector (supplied in kit) and insert the Brown wire into cavity 1.
- 7 Locate the single Brown wire on the Supplementary Facia Harness and insert into cavity 1 in the blower motor connector.
- 8 Remove the Black wire from cavity 5 in the blower motor connector and insert into cavity 2 in the new female 2 way connector.
- 9 Locate the single Black wire on the Supplementary Facia Harness and insert into cavity 5 on the blower motor connector.
- 10 Locate the male 2 way connector on the Supplementary Facia Harness and fit to the female 2 way connector.
- 11 Replace the anti-back out and re-fit the connector to the blower motor switch.

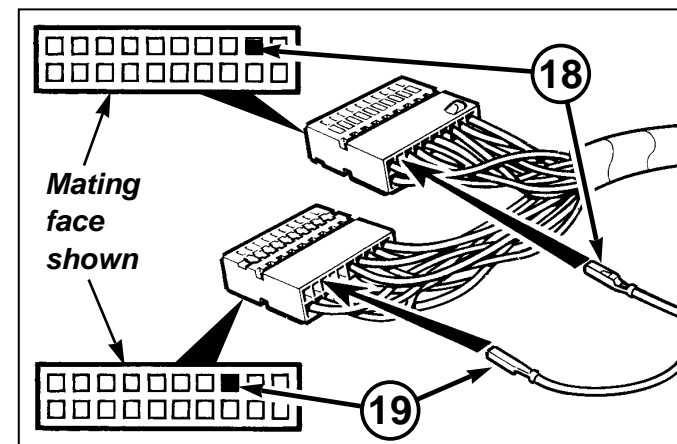
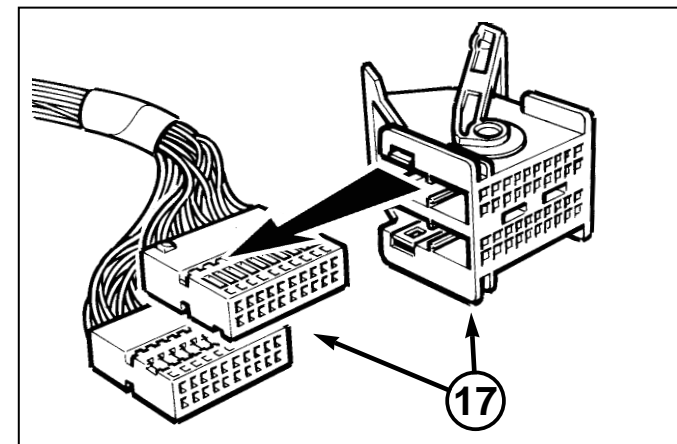
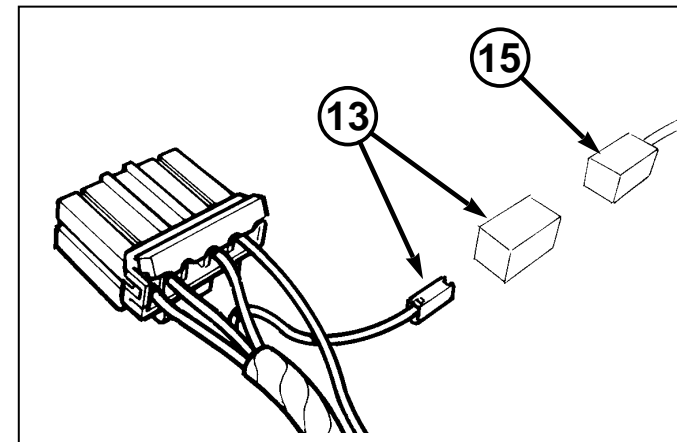
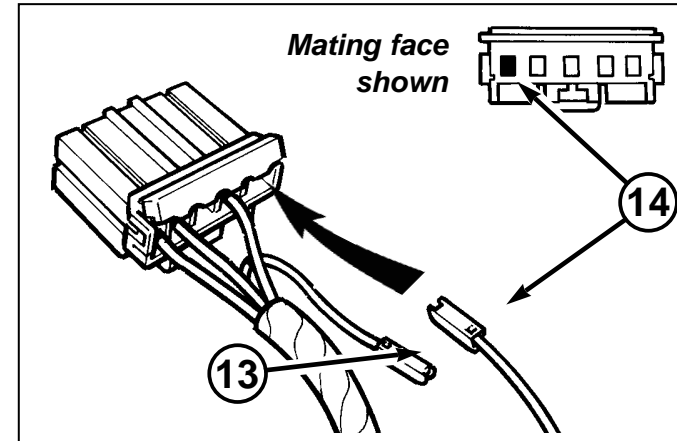
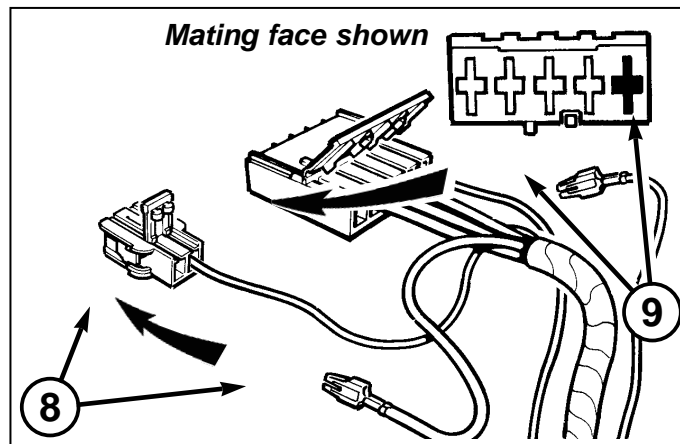
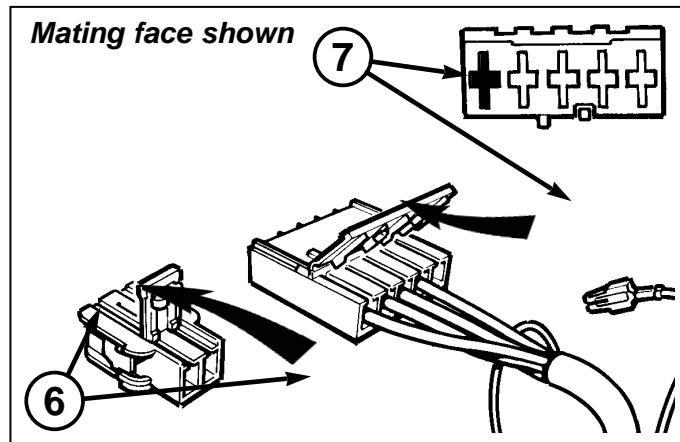

Recirculation Switch Connector

- 12 Remove the 5 way re-circulation switch connector (A) and release the anti-backout.
- 13 Carefully remove the Green/Pink wire in cavity 5 and insert into the new 2 way plastic male connector (supplied in kit).
- 14 Locate the single Green/Pink wire on the Supplementary Facia Harness and insert into cavity 5 in the re-circulation connector.
- 15 Locate the female 2 way connector with single Green/Pink wire on the Supplementary Facia Harness and fit to the new male 2 way connector.
- 16 Replace the anti-back out and re-fit the connector to the recirculation switch.

Main Facia Connector No, 2

- 17 Locate and disassemble the Main facia connector No.2.
- 18 Locate the single Yellow/Black wire on the Supplementary Facia Harness and insert into vacant cavity 9.
- 19 Locate the single Green/Orange wire on the Supplementary Facia Harness and insert into vacant cavity 28.
- 20 Reassemble Connector.
- 21 Secure the Supplementary Facia Harness to the facia with tiewraps.
- NOTE:**
Ensure all wires are secured clear of moving parts.
- 22 Re-assemble instrument pack and refit binnacle to facia.

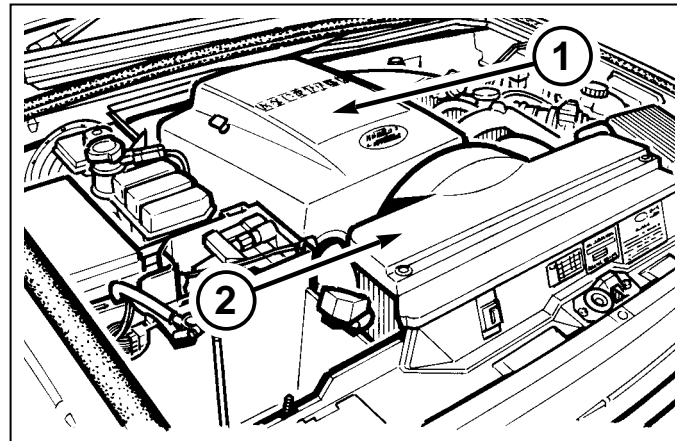

ENGINE BAY PREPARATION

CAUTION:

Ensure engine is cold before starting the following.

- 1 Remove and retain Engine Cover – 3 M10 bolts.
- 2 Remove and retain top fan cowl – 2 turn buckles.
- 3 Remove and retain both headlamp access panels.
- 4 Remove and retain screw securing each indicator lamp.
- 5 Disconnect electrical connectors, remove and retain indicators.
- 6 Remove and retain screws securing LH & RH lower headlamp panel.
- 7 Remove and retain 3 plastic fixings securing front grille.
- 8 Carefully remove the front grille/lower headlamp panel.
- 9 Remove expansion tank cap.
- 10 Remove inspection cover in undertray and remove coolant drain plug. Using a suitable container, drain the coolant (5 litres approx).
- 11 Disconnect heater feed and return pipes in engine bay at the bulkhead.

NOTE:

Plug heater pipes to avoid coolant spillage inside the vehicle when removing heater unit.

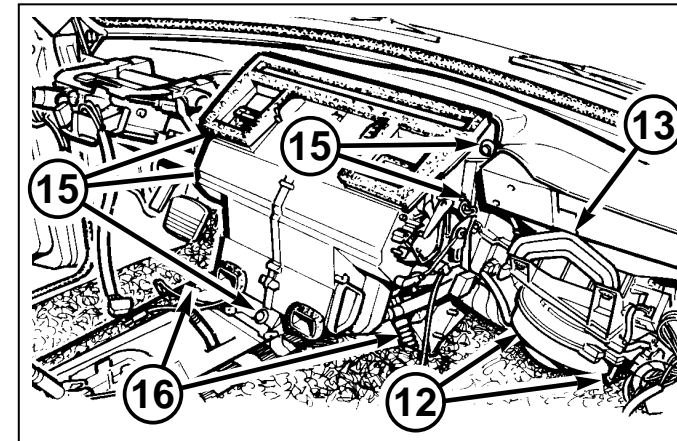
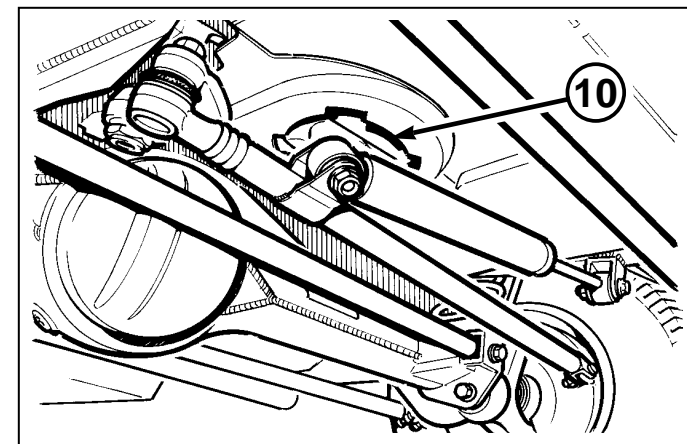
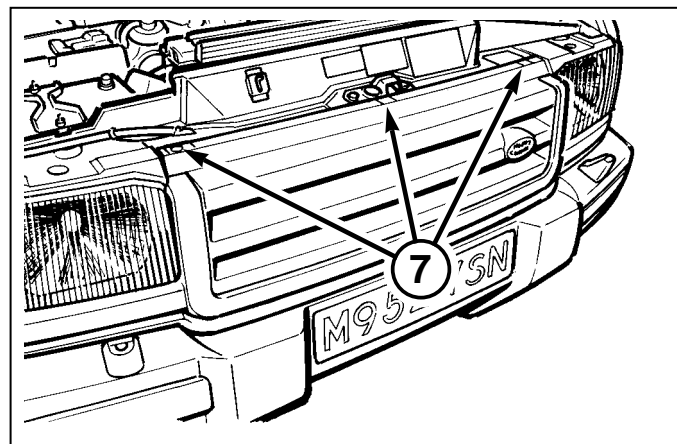
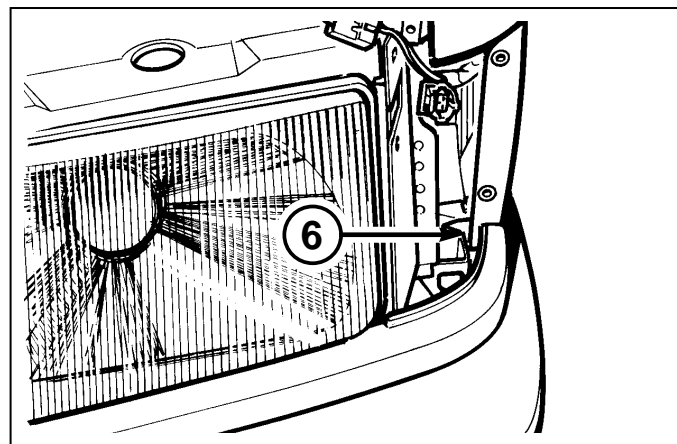
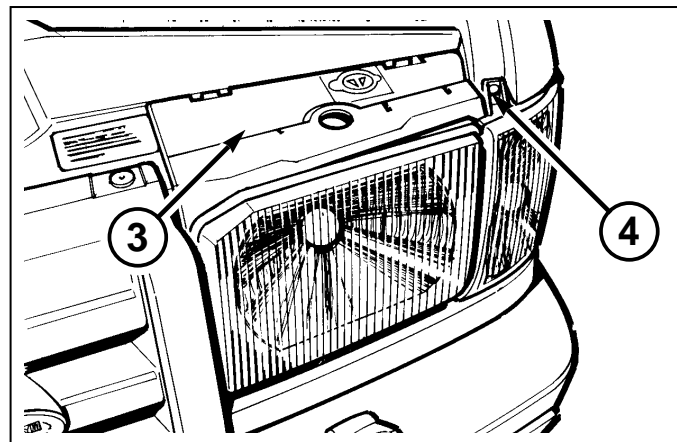

HEATER UNIT – Removal

- 12 Remove and retain 2 lower M8 blower motor retaining nuts.
- 13 Remove and retain the M8 nut securing blower motor mounting bracket.
- 14 Disconnect blower motor connector and remove blower motor.
- 15 Remove and retain 4 M8 nuts and M8 bolt securing the heater.
- 16 Disconnect 2 drain tubes from heater.
- 17 Cut Cable ties to release aerial cable.
- 18 Remove heater unit and discard.

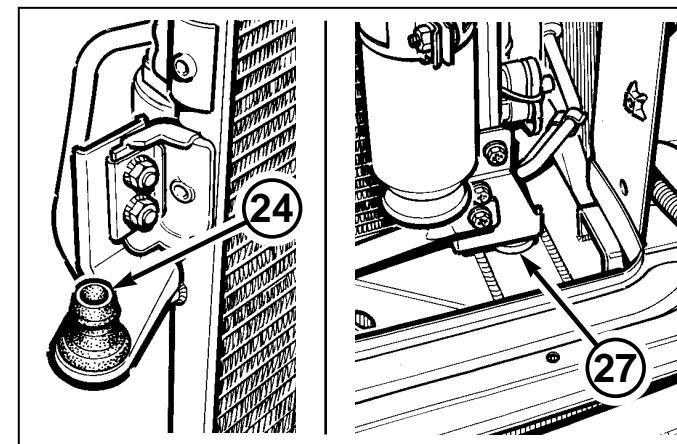
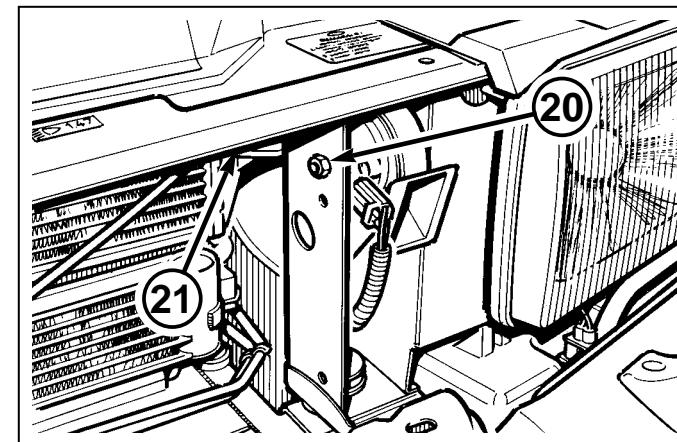

ENGINE BAY

Condenser

- 19 Remove and retain engine driven fan by turning the 32mm nut anti-clockwise with an open ended spanner.
- NOTE:**
Care should be taken during removal not to damage radiator fins.
- 20 Disconnect and remove the RH horn – one M8 nut.
 - 21 Remove both radiator mounting brackets – 2 M8 screws.
 - 22 Carefully lift and ease back the radiator.
 - 23 Separate the rubber mounts from the radiator mounting brackets.
 - 24 Fit the rubber mounts to the support brackets on the condenser.
 - 25 With the radiator pushed up & back carefully feed the condenser through the grille aperture.
 - 26 Position the condenser vertically on the radiator ensuring the rubber mounts locate correctly.
 - 27 Re-fit the radiator locating the rubber feet into its mountings on the chassis.
 - 28 Replace both radiator support brackets with existing fixings.
 - 29 Reconnect and refit the RH horn.

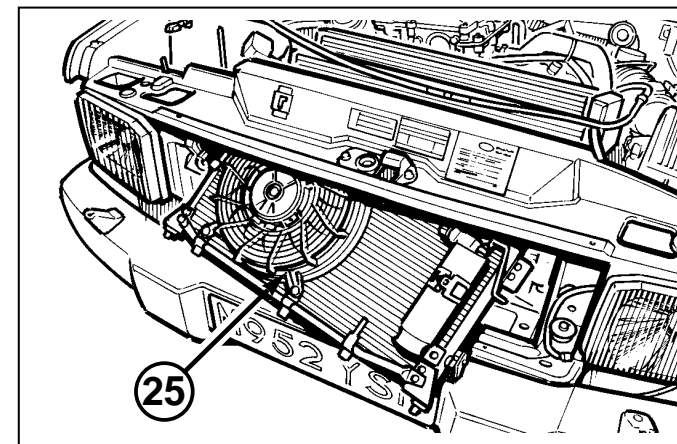

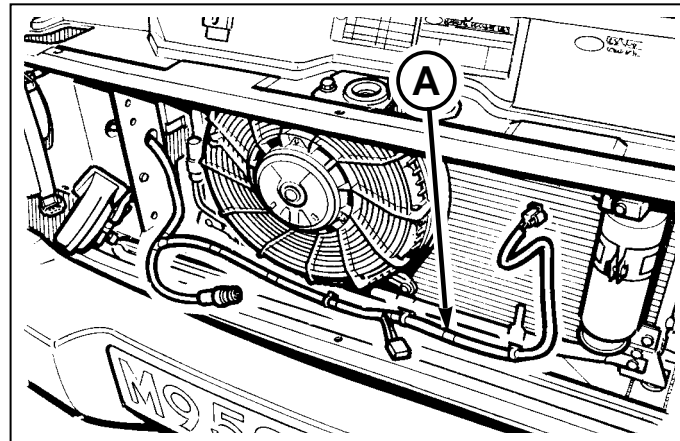

NEW A/C HARNESS

Redundant A/C Harness fitted

Some vehicles will have a redundant A/C Harness already fitted. If there are connectors taped back behind the lower front grille panel (A) the A/C Harness is already fitted and the kit harness can be discarded. Omit the 'New A/C Harness Interior Connections' section below and move on to the 'Drive Belt' section.

Redundant A/C Harness NOT fitted

Vehicles without redundant A/C Harness must fit the interior connections of the 'New A/C Harness' prior to fitting the new evaporator. **NOTE:** The engine bay electrical connections will be carried out in a later section.

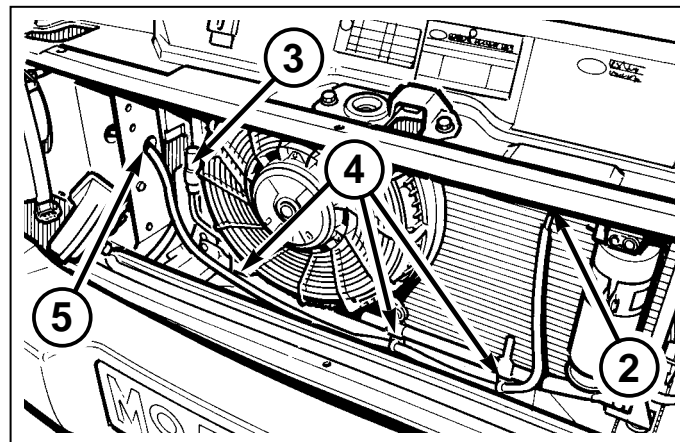

NEW A/C HARNESS INTERIOR CONNECTIONS

- 1 Release battery clamp and remove battery from vehicle.
- 2 Locate the condenser connector on the New A/C Harness (supplied in kit) and fit to the condenser.
- 3 Locate the Fan connector on the New A/C Harness and fit to the condenser fan.
- 4 Route the New A/C Harness along the bottom of the condenser and secure the tiewraps to the 3 holes.
- 5 Route the New A/C Harness through the horn mounting panel, behind the headlamp and out to the battery tray.
- 6 Route the New A/C Harness around the battery tray along side the fusebox to the bulkhead harness grommet.
- 7 Pull back the insulation material from inner wing/bulkhead to reveal harness grommet.
- 8 Cut the nipple from the spare grommet and route the 3 single wires: Yellow/Slate, Yellow/Black and Black wires on the New A/C Harness through the grommet to the interior.

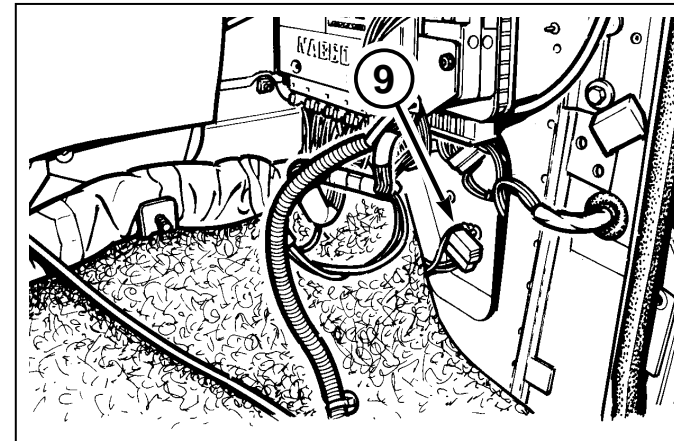
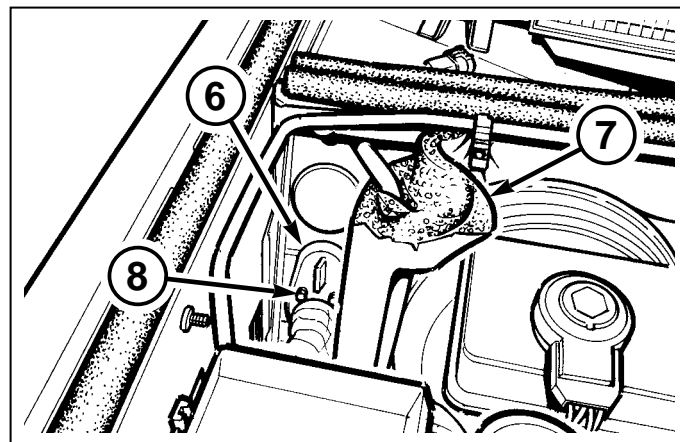
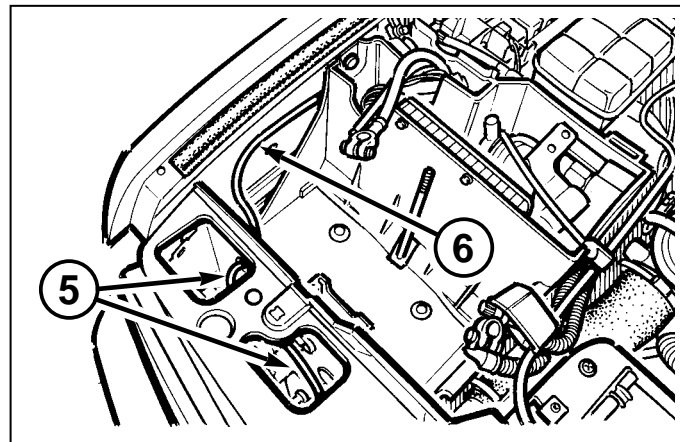

Earth Header

- 9 Remove the Earth header located in the RH footwell and release the anti-back out.
- 10 Insert the Black wire from the New A/C Harness into any free cavity.
- 11 Reassemble and refit the connector.

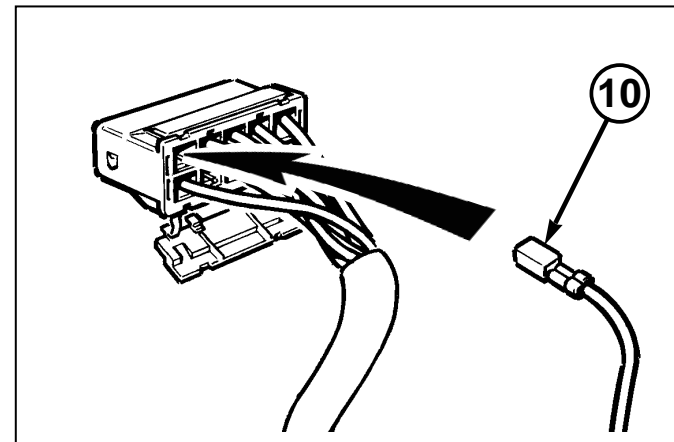

Main Facia Connector 2

- 12 Route the Yellow/black wire to the Main Facia connector No. 2, located on the steering column support bracket. **NOTE:** Left Hand Drive ONLY – Follow and tiewrap the wire to the main vehicle harness.

- 13 Release and disassemble the connector and insert the Yellow/Black wire into cavity 9.
- 14 Reassemble the connector and refit to the steering column support bracket.
- 15 Tiewrap any loose wires back to the main vehicle harness

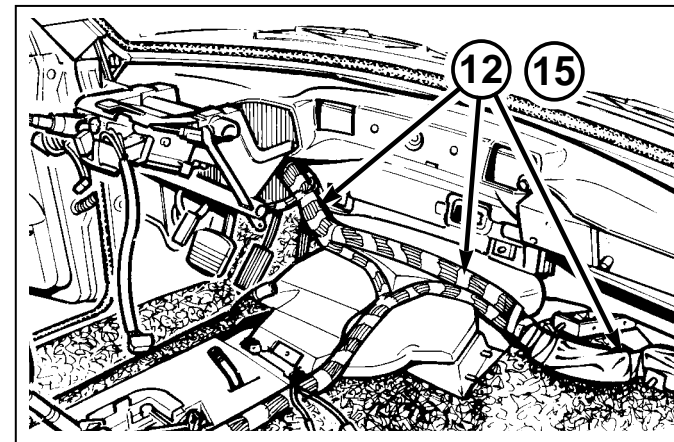

Single Yellow/Slate Wire

- 16 The remaining Yellow/Slate wire is not used; insulate the terminal and tape the wire back to the main harness.

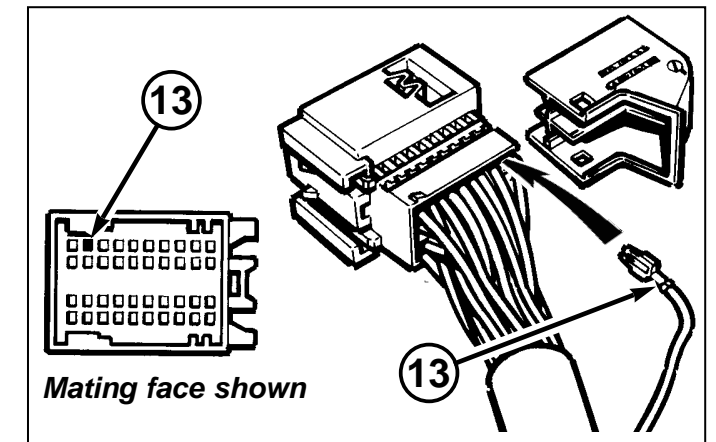
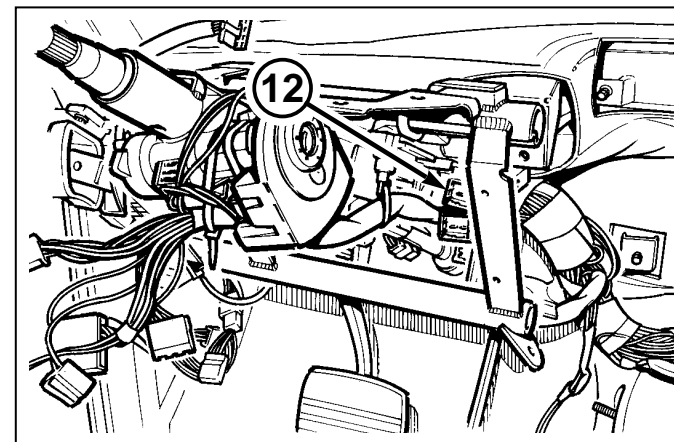

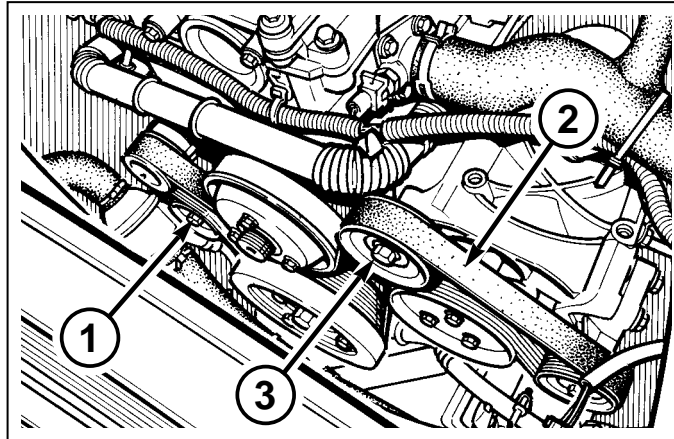

DRIVE BELT

A drive belt tensioner automatically tensions the drive belt eliminating the need for tensioning.

- 1 Release the tension on the drive belt by disengaging tensioner pulley - turn anti-clockwise.
- 2 Remove and discard belt.

ARC Vehicles only

- 3 Remove top idler pulley.

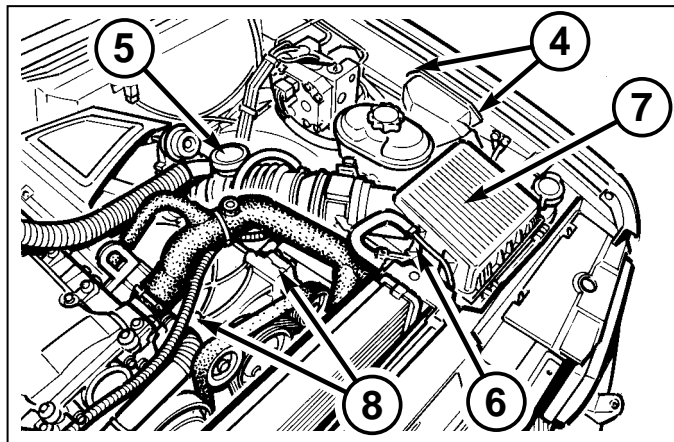

COMPRESSOR

- 4 Remove air intake elbow - 2 plastic fixings.
- 5 Remove engine breather from air intake hose.
- 6 Release air intake hose from air cleaner box, disconnect 3 way connector and lay air intake hose to one side.
- 7 Remove air cleaner box - pull upwards.
- 8 Insert 2 dowels (supplied in kit) to the front compressor mounts in engine bay.
- 9 Position compressor onto its mount and secure with 4 M8x95mm flange head bolts (supplied in kit). Torque to 25Nm.
- 10 Locate the compressor connector taped back to the vehicle harness and fit to the compressor. Secure the connector to the harness with a tie-wrap.
- 11 Release tension on the tensioner pulley and fit new drive belt:

For vehicles with ARC use

Part No. ERR6492.

For vehicles without ARC use

Part No. ERR6944.

NOTE:

Ensure the belt is squarely located on pulleys grooves.

No adjustment of the drivebelt should be necessary. If the drive belt is believed to be slack, refer to service manual.

- 12 Refit engine driven fan.

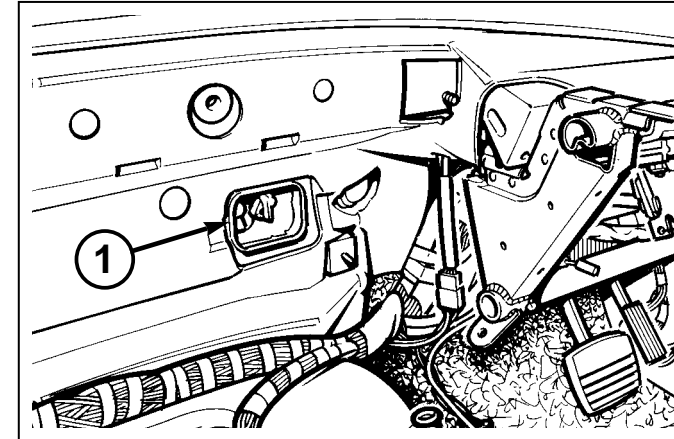
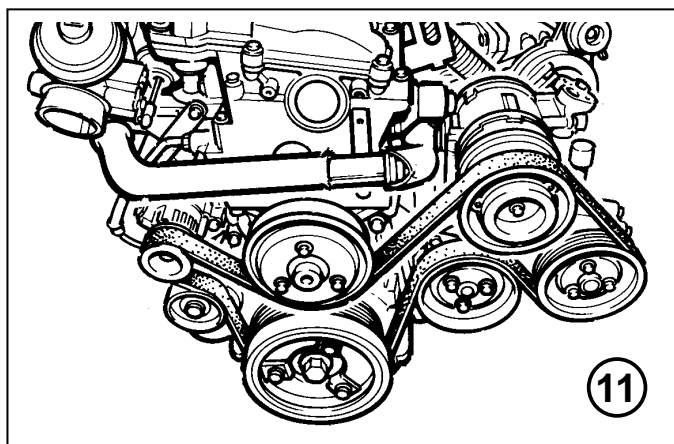
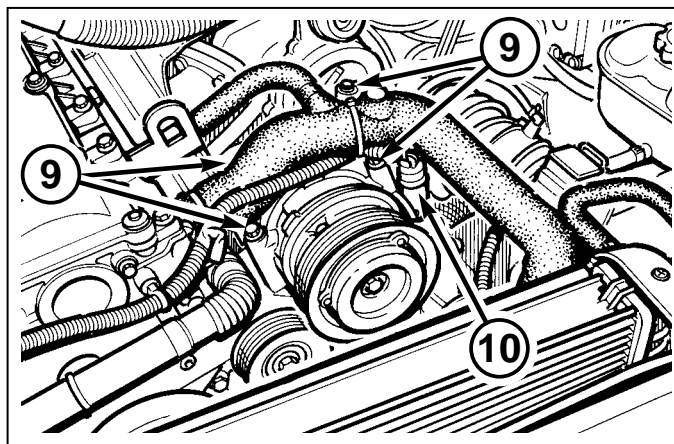

HOSES / PIPES

The compressor and A/C pipes should always have their sealing caps in place and must not be removed until immediately prior to connecting.

NOTE:

Before connecting pipes and hoses lubricate 'O' rings using ND OIL 8.

- 1 From inside the vehicle, remove the pipe access blank in the insulation material.
- 2 Position the Evaporator/Heater unit inside the vehicle (supplied in kit) and secure with existing fixings. Torque the M8 bolt to 25Nm and the 4 M8 nuts to 25Nm.

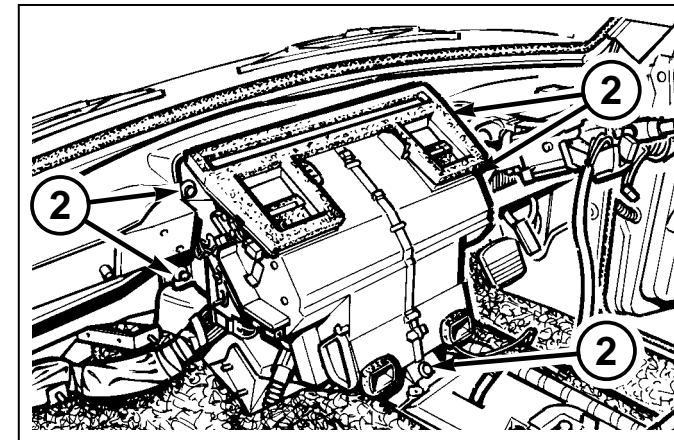

RHD Vehicles ONLY

- 3 Locate the suction pipe - larger diameter (supplied in kit) and position on the bulkhead/inner wing. To fit, feed the compressor end under the ABS Valve Block (A) and carefully position on bulkhead.
- 4 Remove the dust caps and fit the Suction pipe to the evaporator using M6x30mm flange head bolt (supplied in kit). Torque to 10Nm
- 5 Locate the liquid pipe (supplied in kit) position on the bulkhead/inner wing and fit to the evaporator as above using M6x30mm flange head bolt (supplied in kit). Torque to 10Nm

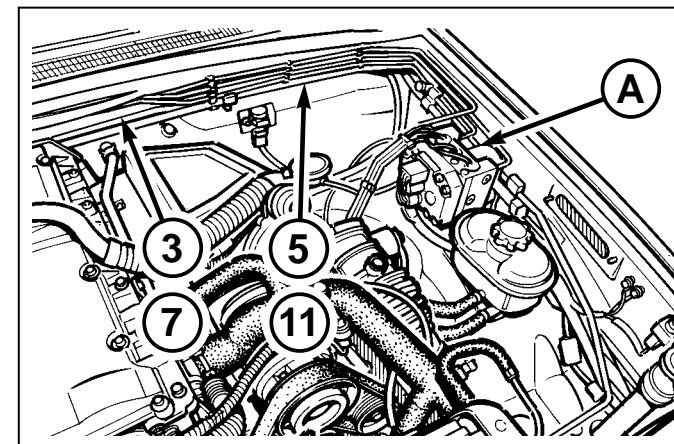

LHD Vehicles ONLY

- 6 Locate the suction pipe - larger diameter (supplied in kit).
- 7 Position the pipes on bulkhead and inner wing panels. Loosely connect the pipes, but do not tighten.
- 8 Remove the dust caps and fit the Suction pipe to the evaporator using M6x30mm flange head bolt (supplied in kit). Torque to 10Nm
- 9 Tighten the two suction pipes with 2 spanners.
- 10 Locate the liquid pipes (supplied in kit).

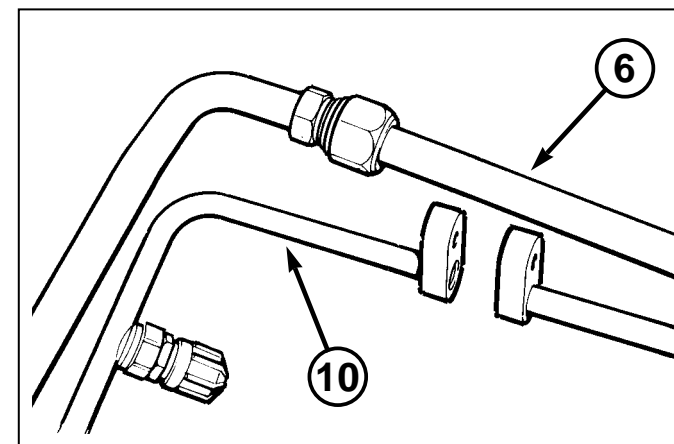

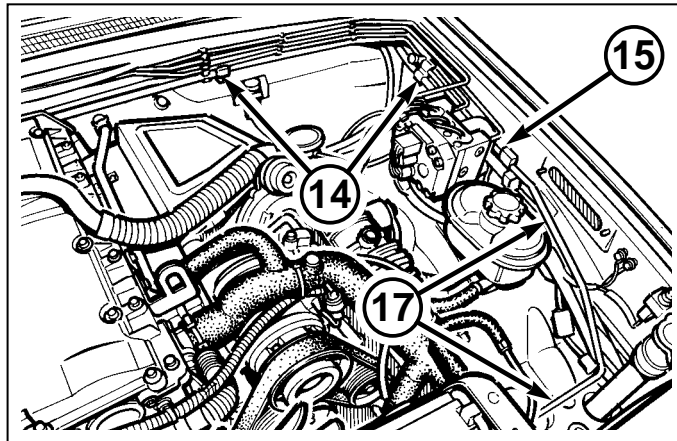

- 11 Position the pipes on bulkhead and inner wing panels. Loosely connect the pipes, but do not tighten.
- 12 Remove the dust caps and fit the liquid pipe to the evaporator using M6x30mm flange head bolt (supplied in kit). Torque to 10Nm.
- 13 Tighten the 2 liquid pipes with 2 spanners.

PIPES & HOSES
All Vehicles

- 14 Position double pipe clips and rubbers around both the suction and liquid pipes, fit over the studs on the bulkhead/ inner wing and press the plastic sleeve in to secure.
- 15 Remove the dust caps, position the Receiver/Drier Pipe on inner wing and connect to the liquid pipe with M6x30mm flange head bolt (supplied in kit). Torque to 10Nm.
- 16 Connect the other end of the Receiver/Drier pipe to the receiver drier with M6x30mm flange head bolt (supplied in kit). Torque to 6Nm.
- 17 Secure the Receiver/Drier pipe to the inner wing panel, top of inner wheel arch panel and horn mounting panel with 3 P clips and M6 bolts (supplied in kit).
- 18 Fit the condenser pipe by feeding it up behind the intercooler and turbo intake hoses.
- 19 Secure the pipe to the condenser with M6x30mm flange head bolt (supplied in kit). Torque to 10Nm.

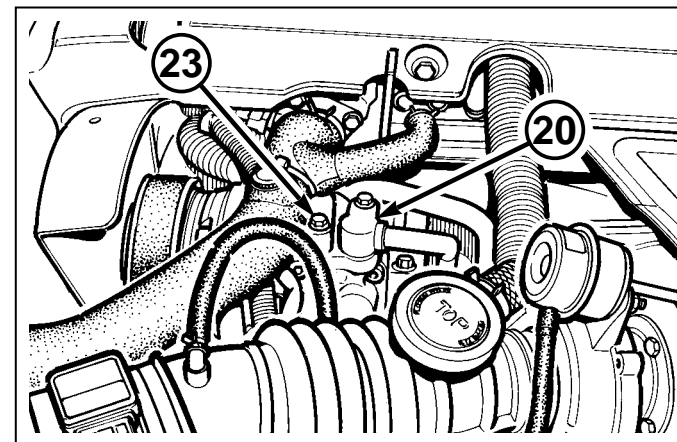
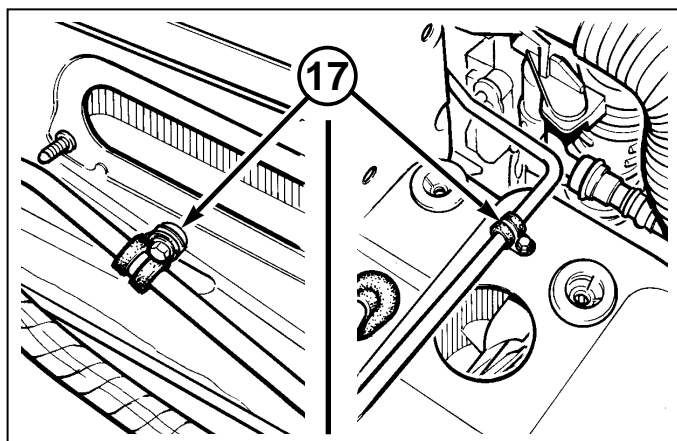
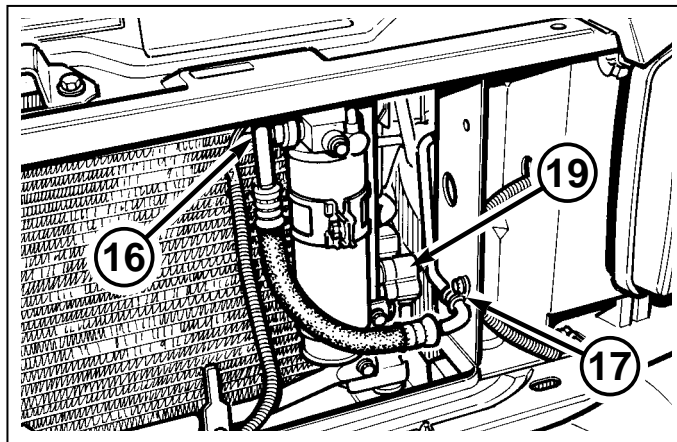
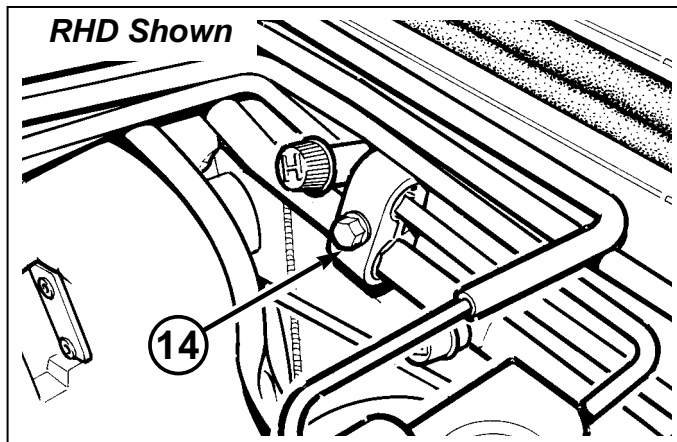

- 20 Secure the other end of the discharge pipe to the rearmost port on the compressor with M6x30mm flange head bolt (supplied in kit). Torque to 10Nm.
- 21 Secure the condenser pipe to the chassis bracket with P clip (supplied in kit).

NOTE:
Access through wheel arch.

- 22 Release jubilee clip on intercooler to turbo pipe for access.
- 23 Position the compressor suction pipe and connect to the compressor with M6x30mm flange head bolt (supplied in kit). Torque to 10Nm.
- 24 Secure the other end of the compressor pipe to the suction pipe with M6x30mm flange head bolt (supplied in kit). Torque to 10Nm.
- 25 Secure the Compressor pipe to ABS mounting bracket and top of wheel arch panel with 2 P clips and M6 bolts (supplied in kit).

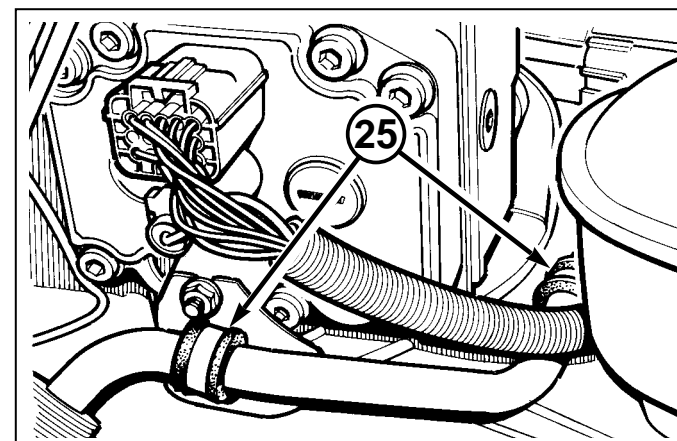
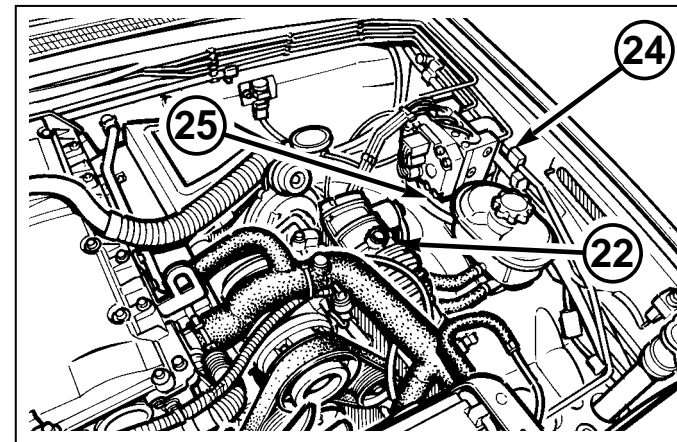
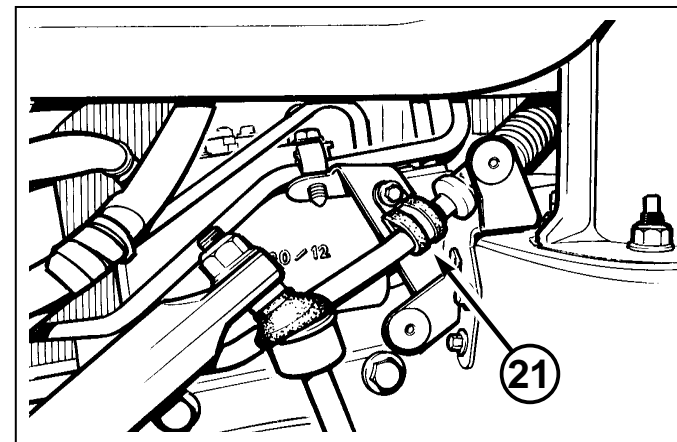

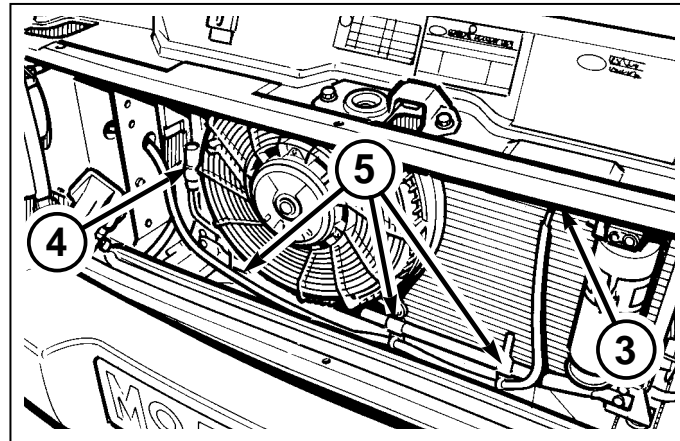

NEW A/C HARNESS Engine bay Connections

Fuse box Relays - All Vehicles

Locate the large and small relays (supplied in kit) and fit to positions R4 & R11 in the fuse box.

Vehicles with Redundant A/C Harness fitted

- 1 Release redundant harness from lower front grille panel - 3 harness clips.
- 2 Release the condenser and fan connectors taped back to the harness.
- 3 Fit condenser fan connector to receiver/drier.
- 4 Fit fan connector to fan.
- 5 Fit the redundant A/C Harness to the bottom of the condenser and insert the tiewraps into the 3 holes.

Move on to to 'Engine Bay Refit' section .

Vehicles without redundant A/C Harness

- 6 Remove the fusebox cover and remove the 3 way and 8 way connectors.
- 7 Remove the alternator and battery positive leads - 2 M8 screws.
- 8 Remove the glowplug connection (yellow/black wire) M5 screw.
- 9 Remove 3 M6 bolts, invert the fusebox and remove 'Fusebox Eng. 5' Connector (C574).
- 10 Release the anti-backout, but do not fully withdraw.
- 11 Locate the single Black/Brown wire on the New A/C Harness and fit into Cavity 4 in the connector.
- 12 Replace the connector and refit the fusebox.

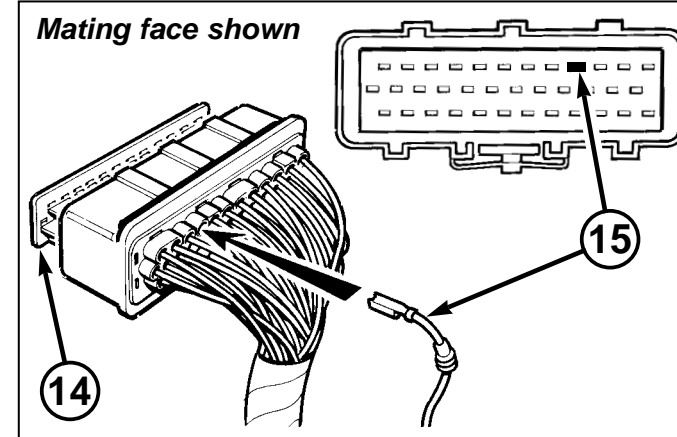
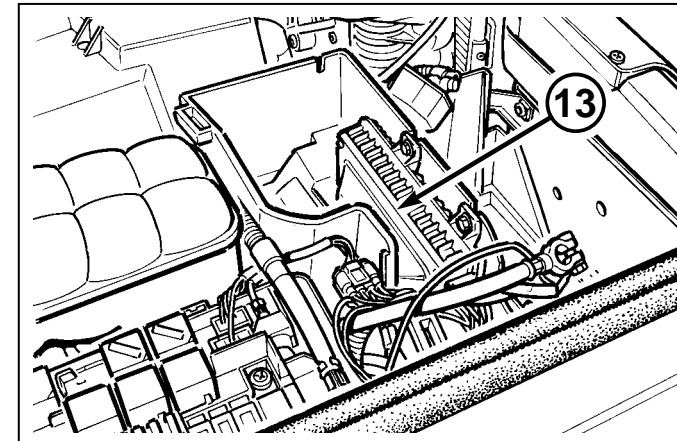
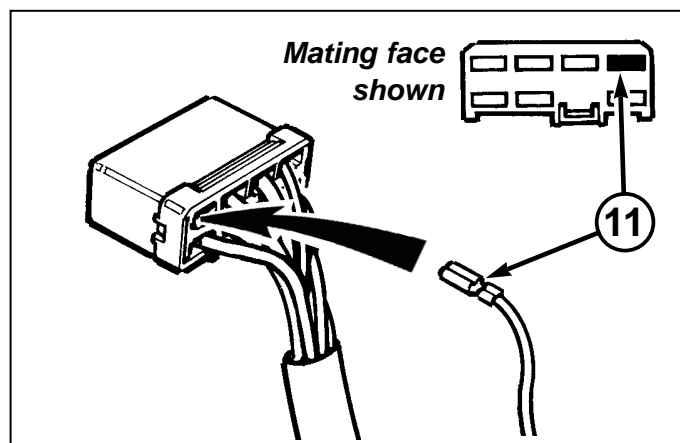
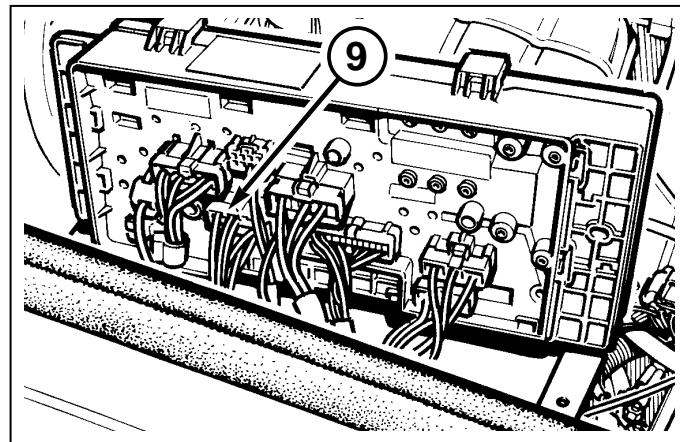
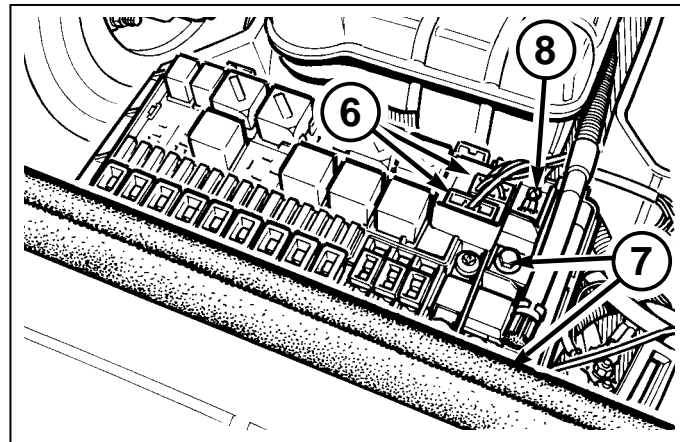

- 13 Release the ECU by removing 3 M6 bolts.
- 14 Disconnect the Black connector and remove the anti-back out.
- 15 Locate the Yellow/Slate wire on the New A/C Harness and insert into cavity 9 in the connector.
- 16 Refit the anti-backout, replace the ECU connector and re-fit the ECU.
- 17 Secure any loose harness in the engine bay with tiewraps.
- 18 Refit insulation material.
- 19 Refit alternator and battery positive leads
- 20 Refit glowplug connection.



ENGINE BAY REFIT

- 1 Refit grille/lower headlamp panel.
- 2 Refit indicators.
- 3 Refit upper radiator fan cowling.
- 4 Replace coolant drain plug and inspection cover.
- 5 Refill coolant. Check level after test run.
- 6 Refit radiator filler cap. Torque to 6Nm.
- 7 De-grease a small area on bonnet locking panel and attach the self-adhesive label (supplied in kit).
- 8 Refit head lamp access panels.

INTERIOR REFIT

- 9 Re-fit both drain tubes to the evaporator.
- 10 Remove three transit keys from evaporator.
- 11 Refit blower motor with existing fixings.
- 12 Refit fascia panel with existing fixings.
- 13 Re-connect heater control cables.
- 14 Re-connect radio aerial.
- 15 Re-connect all electrical connectors.
- 16 Refit radio (where removed).
- 17 Refit column switch assembly and re-connect connectors.
- 18 Remove tape from rotary coupler and refit upper steering column shroud.
- 19 Refit steering wheel.
- 20 Refit air bags - Dealer only.
- 21 Refit centre console with existing fixings.
- 22 Refit both side kick panels.
- 23 Refit battery and secure with clamp.
- 24 Reconnect battery and reset radio.
- 25 Refill coolant and check level after test run.



GENERAL PRECAUTIONS

The Refrigerant used in the air conditioning system is HFC (Hydrofluorocarbon) R134a.

WARNING:

R134a is a hazardous liquid and when handled incorrectly can cause serious injury. Suitable protective clothing must be worn when carrying out servicing operations on the air conditioning system.

WARNING:

R134a is odourless and colourless. Do not handle or discharge in an enclosed area, or in any area where the vapour or liquid can come in contact with naked flame or hot metal. R134a is not flammable but can form a highly toxic gas.

WARNING:

Do not smoke or weld in areas where R134a is in use. Inhalation of concentrations of the vapour can cause dizziness, disorientation, co-ordination, narcosis, nausea or vomiting.

WARNING:

Do not allow fluids other than R134a or compressor lubricant to enter the air conditioning system. Spontaneous combustion may occur.

WARNING:

R134a splashed on any part of the body will cause immediate freezing of that area. Also refrigerant cylinders and replenishment trolleys when discharging will freeze skin to them if contact is made.

WARNING:

The refrigerant used in an air conditioning system must be reclaimed in accordance with the recommendations given with a Refrigerant Recovery Recycling Recharging Station.

NOTE:

Suitable protective clothing comprises: wrap around safety glasses or helmet, heat proof gloves, rubber apron or waterproof overalls and rubber boots.

REMEDIAL ACTIONS

- 1 If liquid R134a strikes the eye, do not rub it. Gently run large quantities of eyewash over the eye to raise the temperature. If eyewash is not available cool, clean water may be used. Cover eye with clean pad and seek immediate medical attention.
- 2 If liquid R134a is splashed on the skin run large quantities of water over the area as soon as possible to raise the temperature. Carry out the same actions if skin comes into contact with discharging cylinders. Wrap affected parts in blankets or similar material and seek immediate medical attention.
- 3 If suspected of being overcome by inhalation of R134a vapour seek fresh air. If unconscious remove to fresh air.

NOTE:

Due to its low evaporating temperature of -30°C, R134a should be handled with care.

WARNING:

Do not allow a refrigerant container to be heated by a direct flame or to be placed near any heating appliance. A refrigerant container must not be heated above 50°C.

WARNING:

Do not leave a container of refrigerant without its cap fitted. Do not transport a container of refrigerant that is unrestrained, especially in the boot of a car.



SERVICING EQUIPMENT

The following equipment is required for full servicing of the air conditioning system.

Recovery, recycling and charging station.

Leak Detector.

Thermometer +20°C to -60°C

Safety goggles and gloves.

CHARGING

WARNING:

Servicing must only be carried out by an operator familiar with the vehicle system charging procedure and testing equipment. All operations must be carried out in a well-ventilated area away from open flame and heat sources.

CAUTION:

Overcharging air conditioning system will cause excessive head pressure. Refer to workshop manual for correct charging procedure.

REFRIGERANT TO CHARGE SYSTEM IS 700gms

LEAK TEST SYSTEM

The following instructions refer to an electronic type of Refrigerant Leak Detector for use the R134a which are the safest and most sensitive.

- 1 Place the vehicle in a well ventilated area but free from draughts, as leakage from the system could be dissipated without detection.
- 2 Follow the instructions issued by the manufacturer of the particular leak detector being used.
- 3 Commence searching for leaks by passing the detector probe around all joints and components; refrigerant gas is heavier than air.
- 4 Insert the probe into the evaporator drain tube. Switch the heater blower on and off at intervals of ten seconds. Any leakage refrigerant will be gathered in by the blower and detected.
- 5 Insert the probe between the magnetic clutch and compressor to check the shaft seal for leaks.
- 6 Check all TXV valve connections, valve plate, head and base plate joints and back seal plate.
- 7 Check all A/C pipe union connections to all components for leaks ie. condenser, receiver/drier evaporator, compressor.
- 8 If any leaks are found, the system must be discharged before rectification.
- 9 Rectify any leaks and re-check for leaks during evacuation prior to charging.

NOTE:

Check performance of air conditioning.



AIR CONDITIONING SYSTEM - PERFORMANCE TEST

Carry out this test with bonnet and doors or windows open, air conditioning switched on, temperature control set to cold and blower at maximum speed. Set the air supply control to supply fresh air.

- 1 Close low pressure valve on Refrigerant Station.
- 2 Close high pressure valve on Refrigerant Station.
- 3 Connect Refrigerant Station to the high and low pressure servicing connections.
- 4 Insert bulb thermometer into cold air outlet and position dry and wet bulb thermometer close to outside air inlet. Do not spill water from the wet thermometer (psychrometer).

- 5 Start engine and run it at 1500 rev/min for 10 minutes with air conditioning switched on.
- 6 Check that sight glass is free from bubbles.
- 7 Read both pressure gauges and thermometers. Check reading against table below with humidity between 60% and 80%. If readings are incorrect refer to COMPLAINTS DURING TEST in Fault Finding section of the Service Manual.
- 8 Switch off air conditioning, stop engine, disconnect test equipment.

PERFORMANCE RANGE			
Intake Temperature	Outlet Temperature	Low Pressure	High Pressure
20 - 24°C	4 - 10°C	18 - 28 lbf/in ² 1.2 - 1.9 bar	213 - 299 lbf/in ² 14.7 - 20.06 bar
25 - 29°C	9 - 19°C	27 - 37 lbf/in ² 1.9 - 2.6 bar	256 - 341 lbf/in ² 17.6 - 23.5 bar
30 - 35°C	20 - 27°C	33 - 47 lbf/in ² 2.3 - 3.2 bar	299 - 384 lbf/in ² 20.6 - 26.5 bar

Ambient Temperature		Compound Gauge Readings		High Pressure Gauge Readings	
°C	°F	bar	lbf/in ²	bar	lbf/in ²
16	60	1,03 - 1,4	15 - 20	6,9 - 10,3	100 - 150
26,7	80	1,4 - 1,72	20 - 25	9,6 - 13,1	140 - 190
38	100	1,72 - 2,1	25 - 30	12,4 - 15,5	180 - 225
43,5	110	2,1 - 2,4	30 - 35	14,8 - 17,2	215 - 250