



ACCESSORIES

WARNING

Accessories which are not properly fitted can be dangerous. Read the instructions carefully prior to fitting. Whilst fitting, comply with the instructions at all times. If in doubt, contact your nearest Land Rover Dealer.

ACHTUNG!

Nicht sachgemäß montiertes Zubehör kann gefährlich sein. Lesen Sie die Montageanleitung sorgfältig, bevor Sie das Teil montieren. Halten Sie sich bei der Montage an die Anleitung. Bei Unsicherheiten wenden Sie sich bitte an Ihren Land Rover Händler.

AVERTISSEMENT

Les accessoires qui ne sont pas correctement montés risquent d'être dangereux. Veuillez lire soigneusement les instructions avant d'effectuer la pose. Respectez toujours les instructions en cours de pose. En cas de doute, consultez votre concessionnaire Land Rover local.

AVVERTENZA

Gli accessori non sistemati come previsto possono essere pericolosi. Leggere attentamente le istruzioni prima del fissaggio. Durante il montaggio seguire sempre le relative istruzioni. In caso di dubbio rivolgersi al più vicino concessionario della Land Rover.

AVISO

Aquellos accesorios que no hayan sido ajustados debidamente pueden resultar peligrosos. Lea las instrucciones detenidamente antes de iniciar el montaje. Durante el montaje siga las instrucciones en todo momento. En caso de duda póngase en contacto con su Concesionario de Land Rover.

ADVERTÊNCIA!

Os Acessórios que não são montados adequadamente podem ser perigosos. Leia as instruções cuidadosamente antes de montar. Durante a montagem, obedeça as instruções todo o tempo. Se tiver alguma dúvida, contacte o Concessionário Land Rover mais próximo.

WAARSHUWING

Accessoires die niet op de juiste wijze zijn gemonteerd kunnen gevaar opleveren. Lees zorgvuldig de instructies alvorens met de montage te beginnen. Houd u tijdens de montage te allen tijde aan de instructies. Neem bij twijfel contact op met de dichtstbijzijnde Land Rover dealer.

ΠΡΟΕΙΔΟΠΟΙΗΣΗ

Τα προαιρετικά εξαρτήματα που δεν έχουν τοποθετηθεί σωστά μπορεί να είναι επικίνδυνα. Διαβάστε τις οδηγίες πριν προχωρήσετε στην τοποθέτησή τους. Κατά την τοποθέτησή, τηρείτε συνεχώς τις οδηγίες. Αν έχετε οποιαδήποτε αμφιβολία, επικοινωνήστε με τον πλησιέστερο αντιπρόσωπο της.

注意

正しく取り付けられていない備品があると、事故の原因になります。取付ける前にこのマニュアルをよくお読みください。取付けの際は必ずこのマニュアルにある指示に従ってください。何か不明な点がありましたら、お近くのランド・ローバー社のディーラーまでお問い合わせください。



FITTING INSTRUCTION

Side Protection Tubes - Stainless Steel

EINBAUANLEITUNG

Seitliche Schutzrohre aus rostfreiem Stahl

INSTRUCTION DE MONTAGE

Tubes de protection latéraux - acier inoxydable

ISTRUZIONI PER L'USO

Tubi laterali di protezione - acciaio inossidabile

INSTRUCCIONES DE MONTAJE

Tubos de protección lateral - Acero inoxidable

INSTRUÇÕES DE MONTAGEM

Tubos de protecção lateral - Aço inoxidável

MONTAGEHANDLEIDING

Beschermingsbuis - Roestvrij staal

ΟΔΗΓΙΑ ΤΟΠΟΘΕΤΗΣΗΣ

Πλευρικοί σωλήνες προστασίας - Ανοξειδωτου χάλυβα

取付用マニュアル

サイド プロテクション チューブ - ステンレス スチール

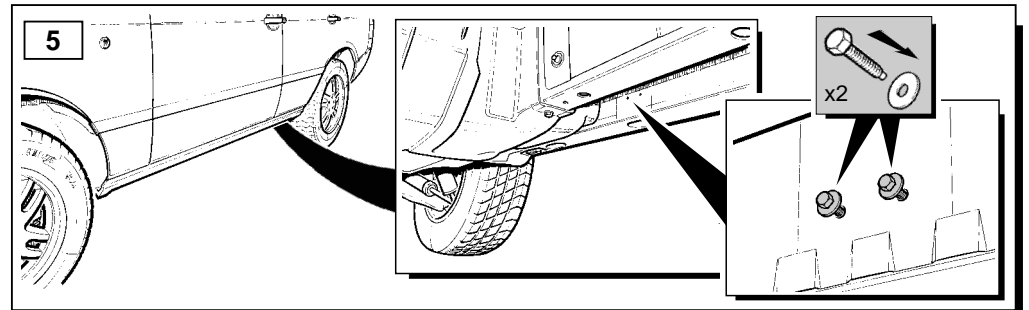
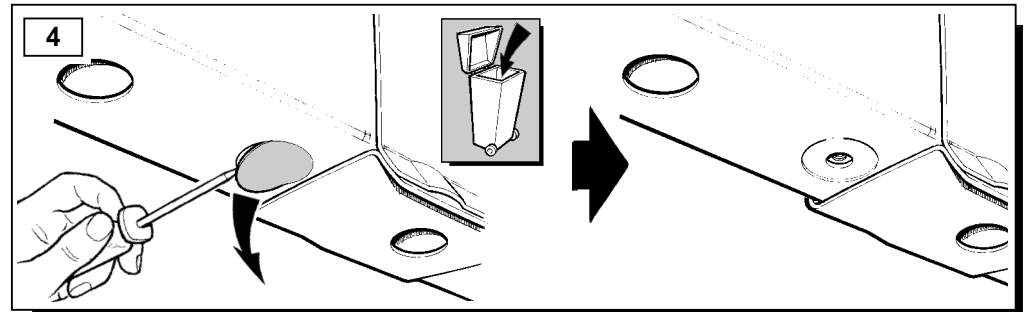
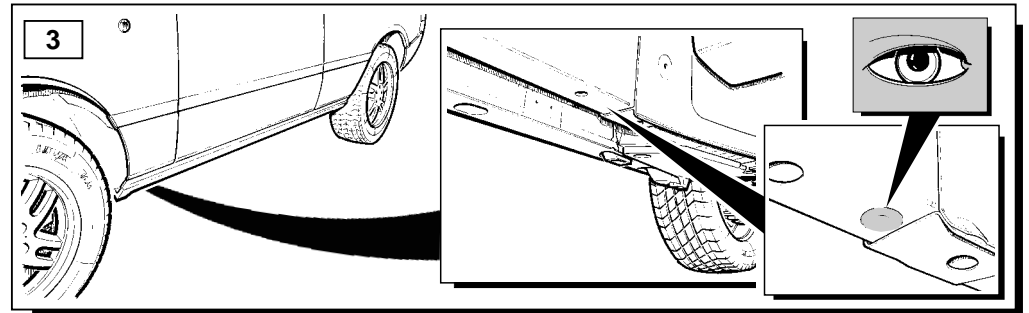
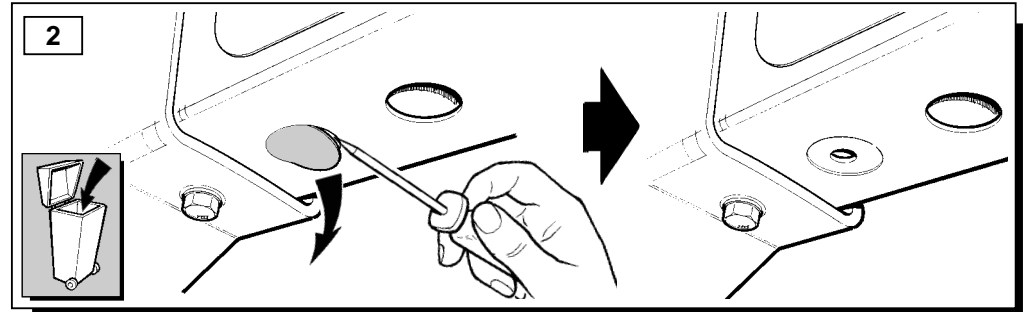
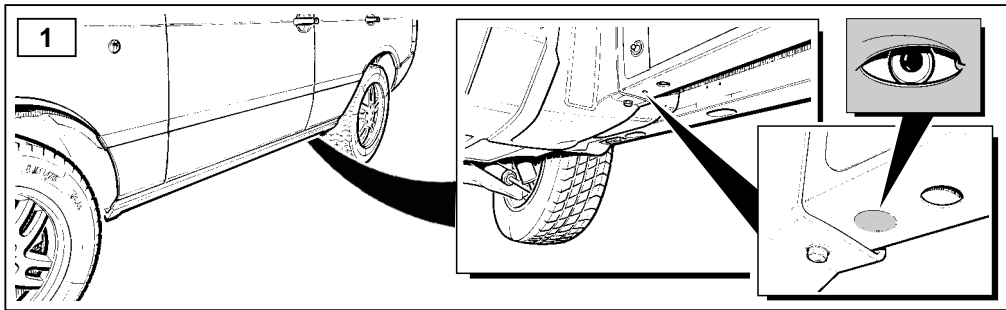
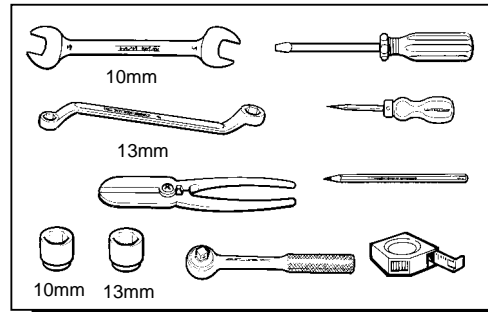
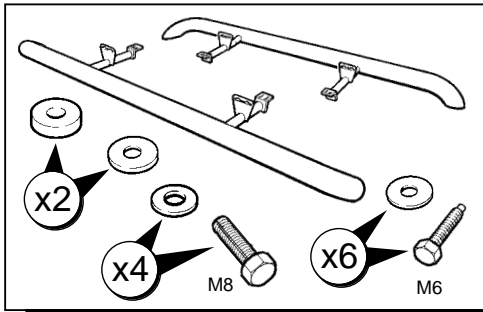
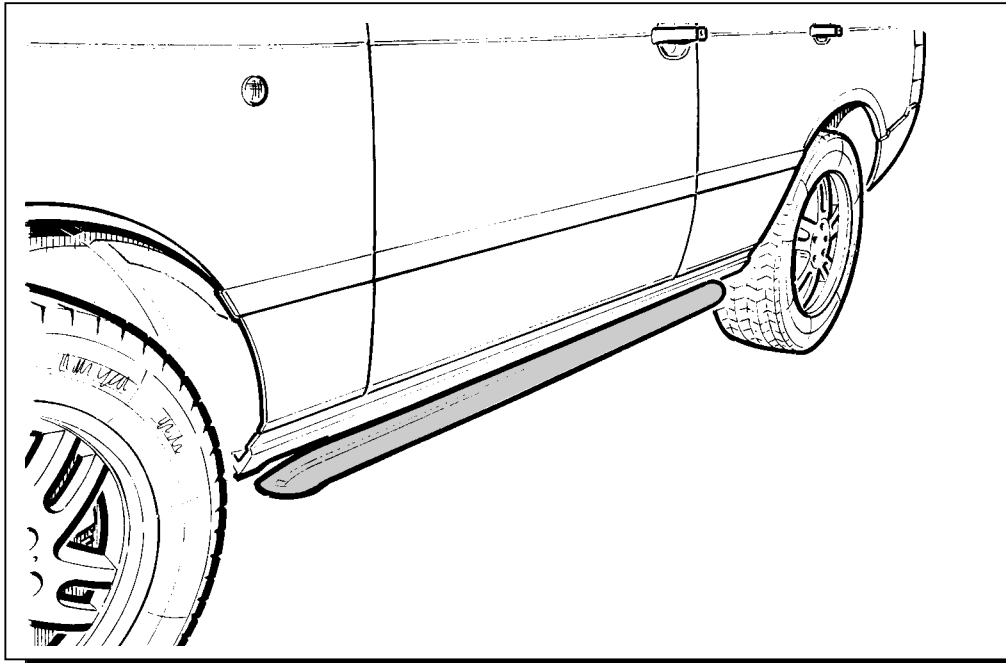

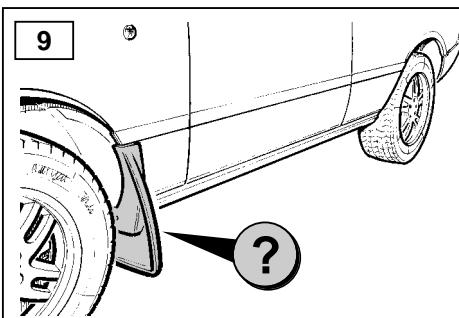
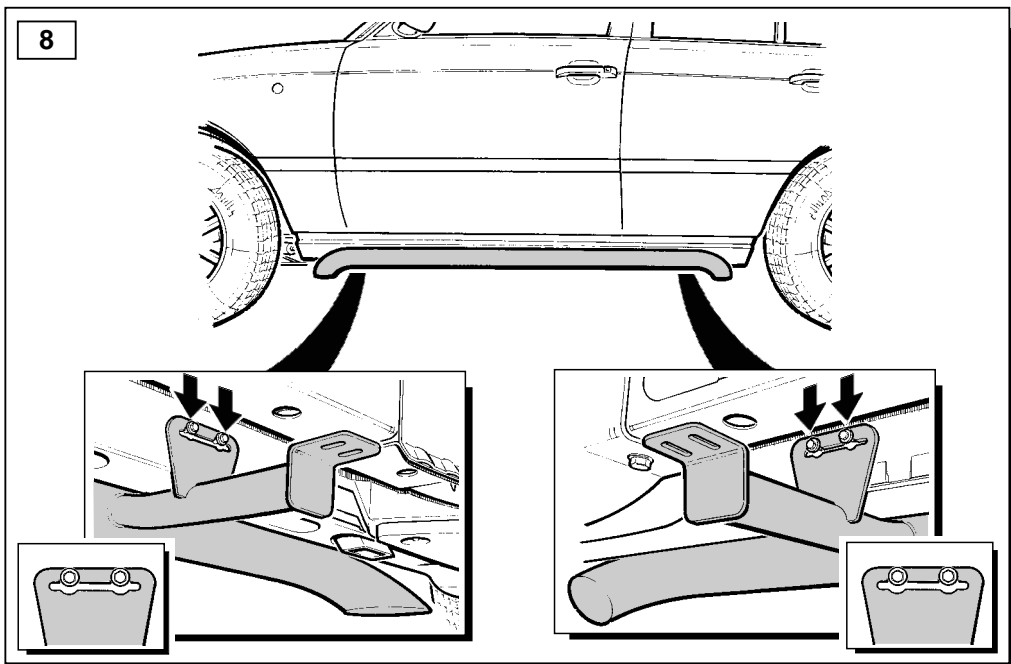
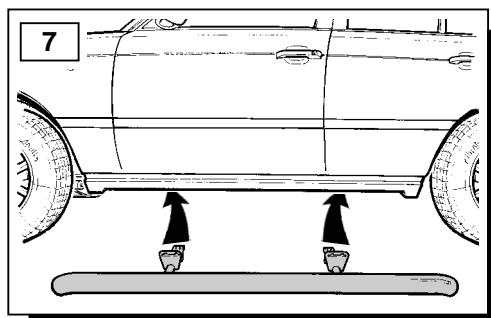
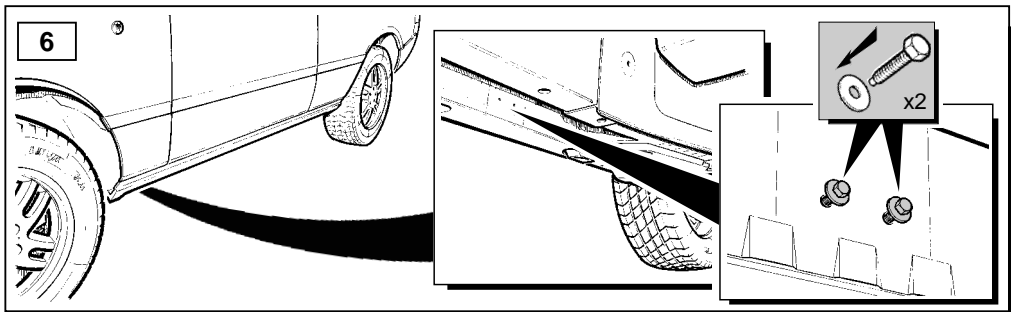

- GB** Follow procedures 10 to 13 then 18 onwards.
- D** Vorgänge 10 bis 13 und dann ab 18 durchführen.
- F** Suivre les procédures de 10 à 13 puis à partir de 18.
- I** Seguire le procedure da 10 a 13 e poi da 18 in avanti.
- E** Seguir los procedimientos 10 hasta 13 y luego de 18 en adelante.
- P** Siga os procedimentos 10 a 13 a, seguir de 18 em diante.
- NL** Verricht handelingen 10 t/m 13 en vanaf 18.
- GR** Ακολουθήστε τις διαδικασίες 10 έως 13 και κατόπιν από την 18 και μετά.
- H** まず、10から13の手順に従い、その後18以降の手順に従います。

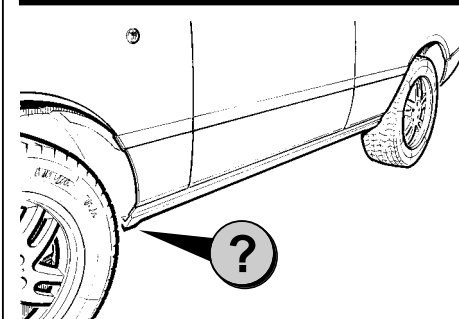

- GB** Follow procedures 14 to 29 then 35 onwards.
- D** Vorgänge 14 bis 29 und dann ab 35 durchführen.
- F** Suivre les procédures de 14 à 29 puis à partir de 35.
- I** Seguire le procedure da 14 a 29 e poi da 35 in avanti.
- E** Seguir los procedimientos 14 hasta 29 y luego de 35 en adelante.
- P** Siga os procedimentos 14 a 29 a, seguir de 35 em diante.
- NL** Verricht handelingen 14 t/m 29 en vanaf 35.
- GR** Ακολουθήστε τις διαδικασίες 14 έως 29 και κατόπιν από την 35 και μετά.
- H** まず、14から29の手順に従い、その後35以降の手順に従います。

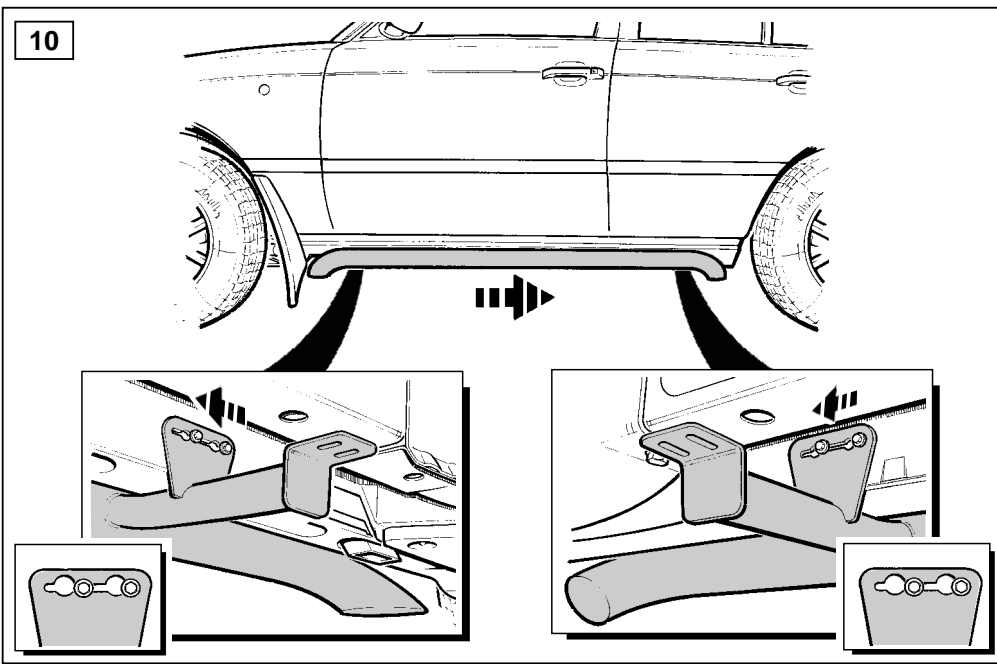

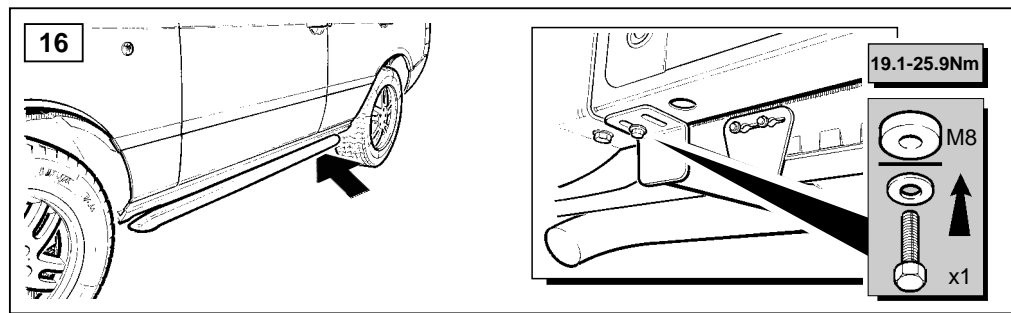
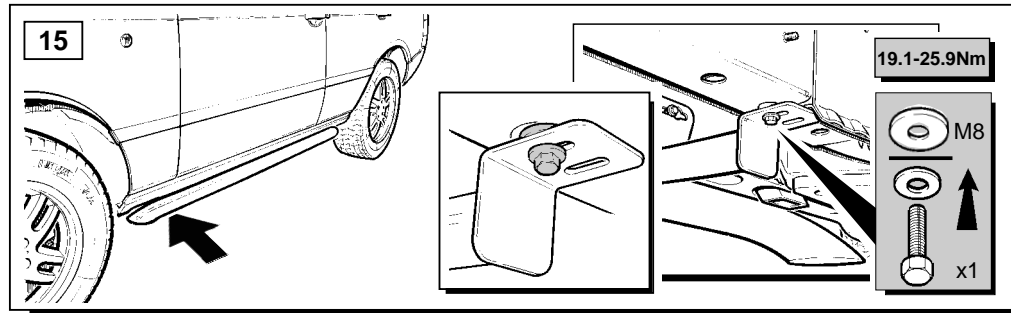
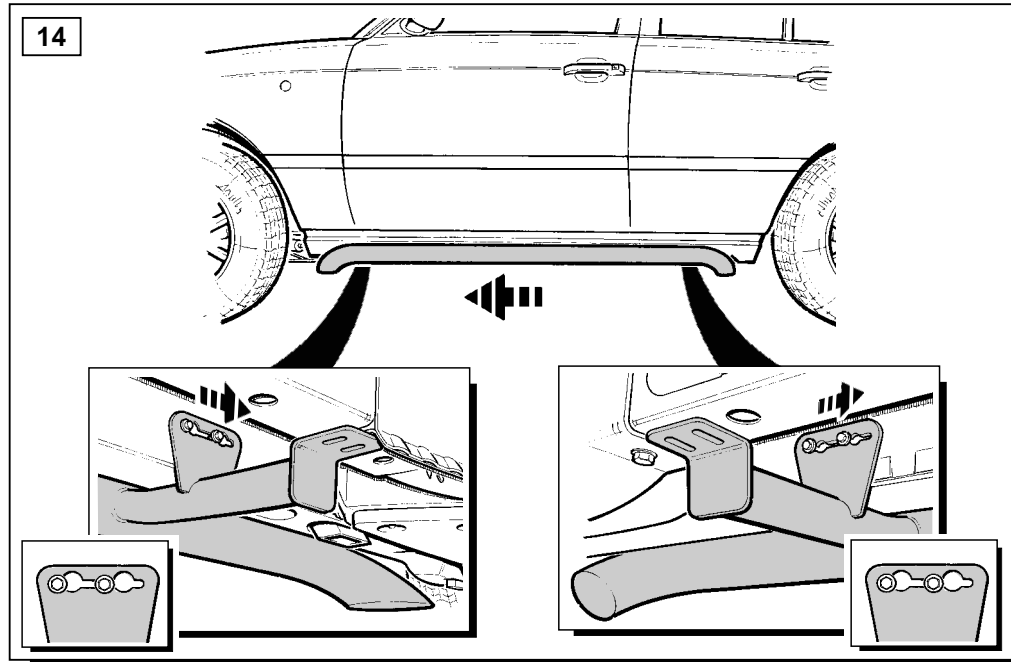
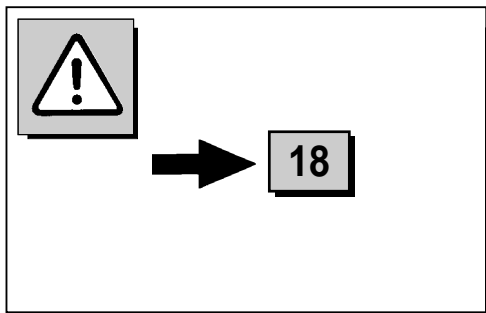
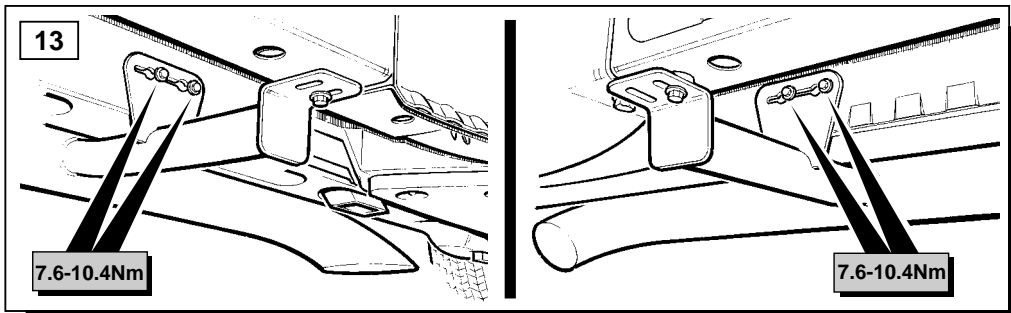
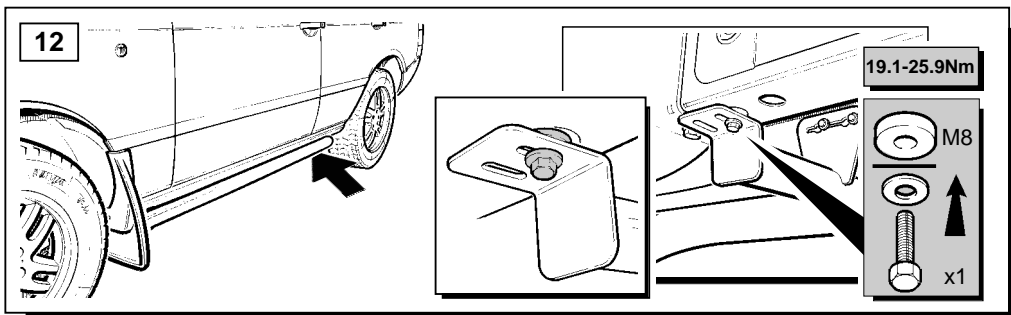
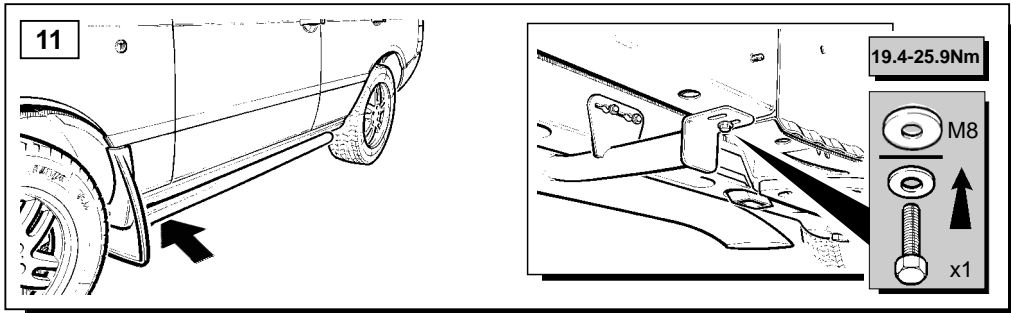

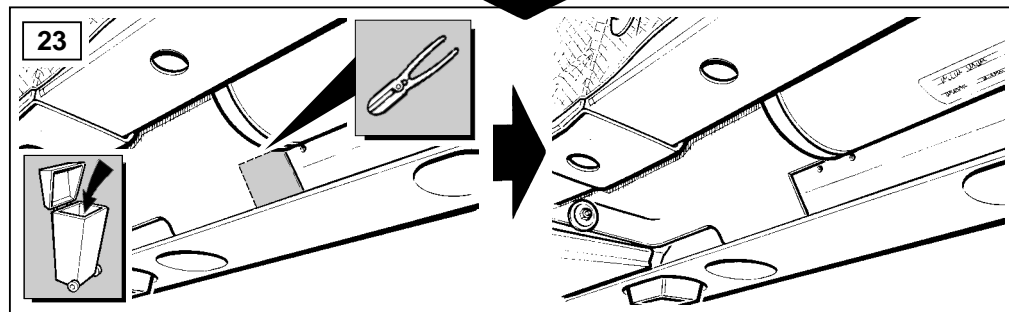
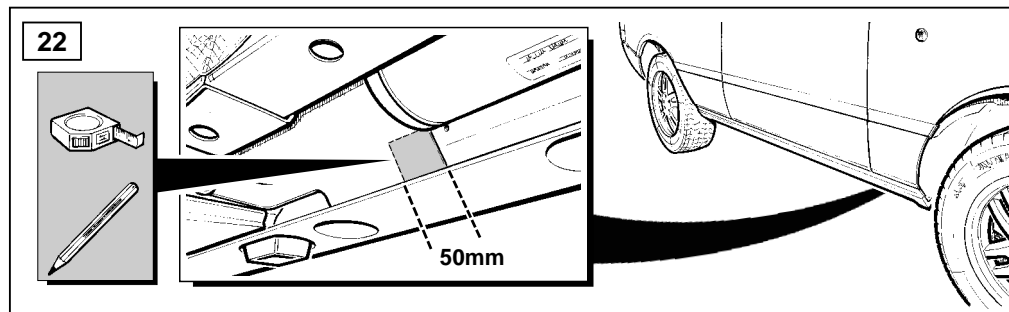
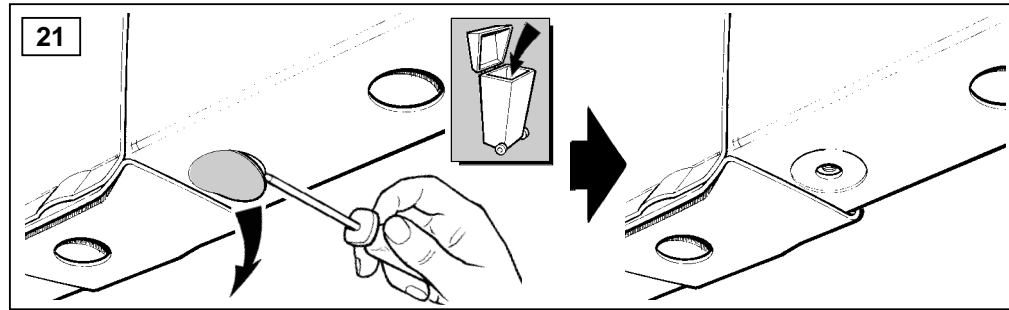
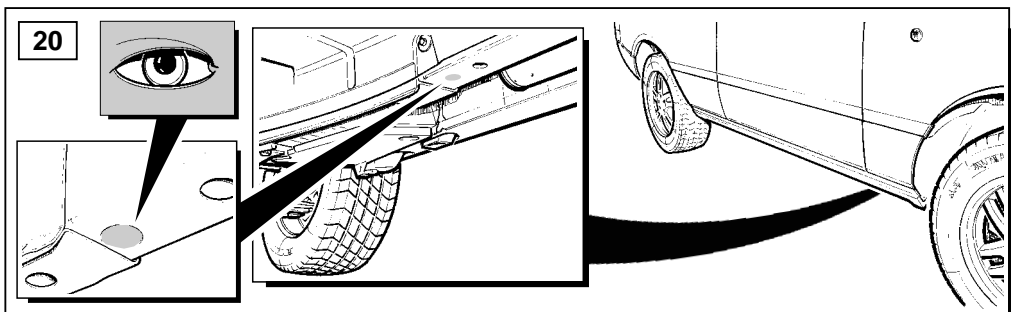
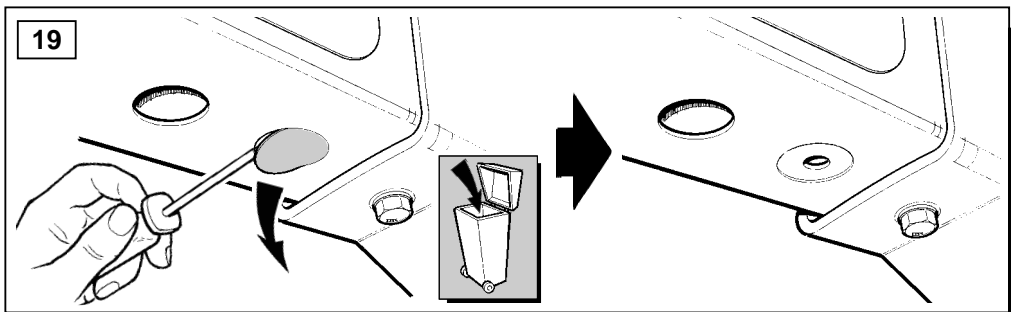
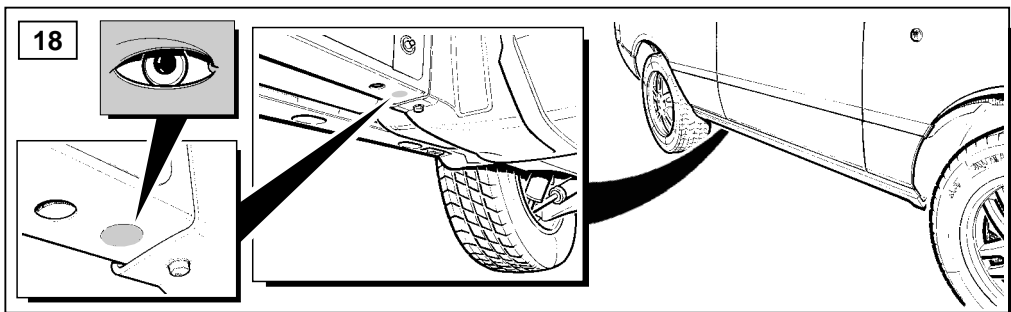
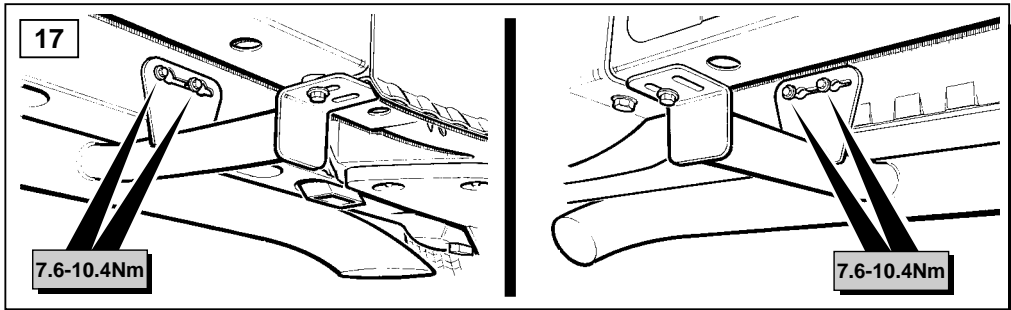

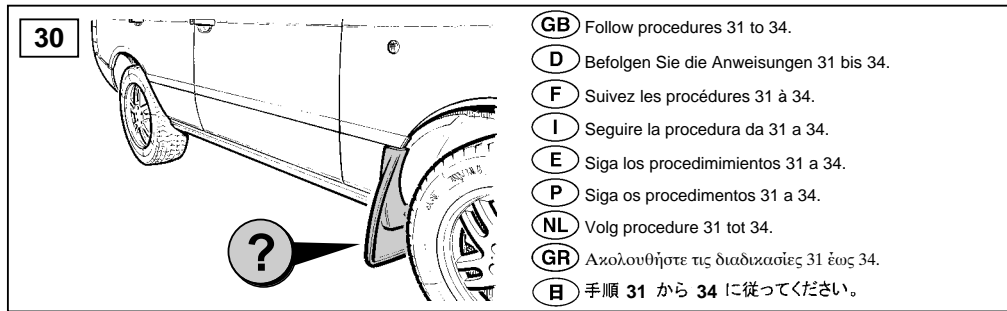
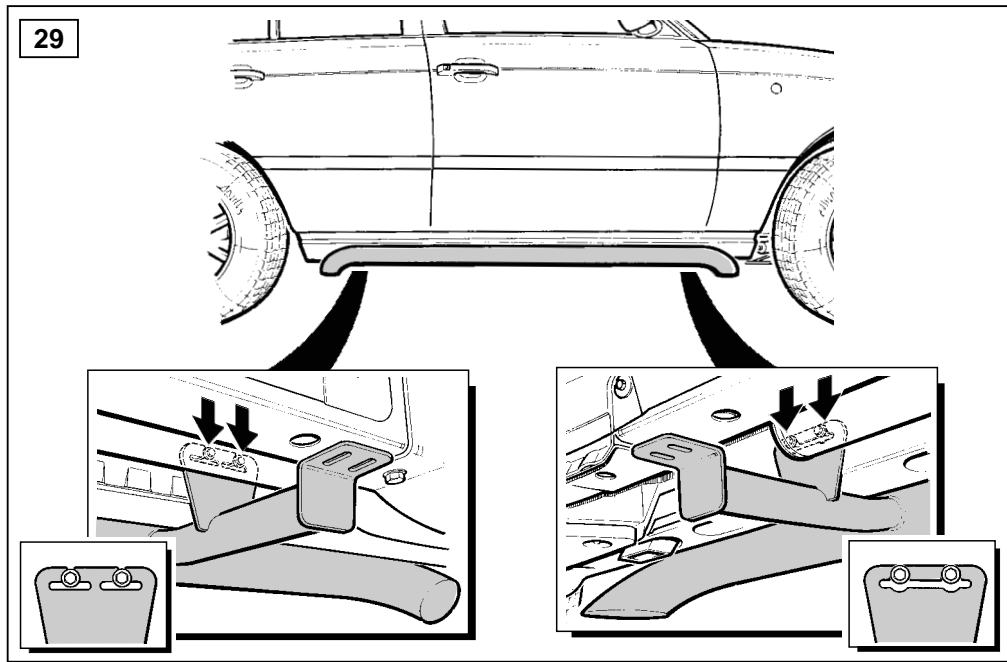
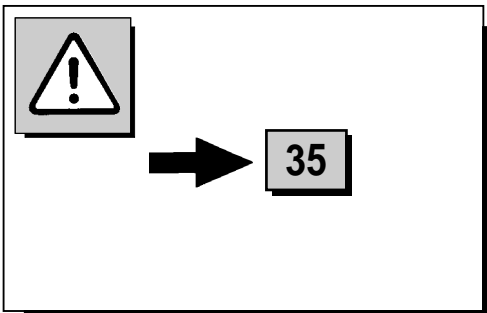
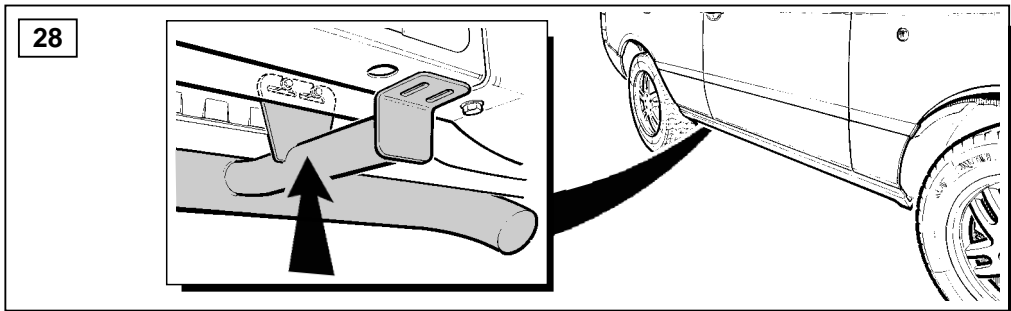
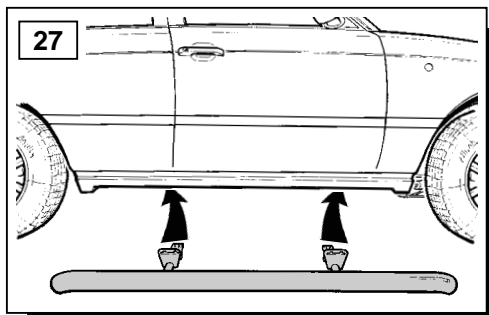
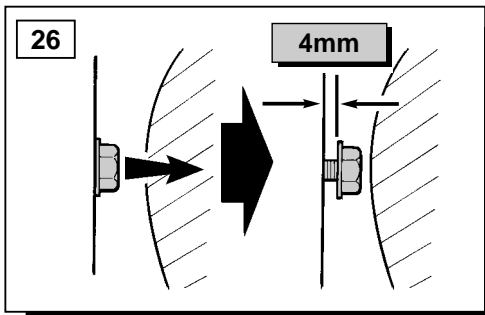
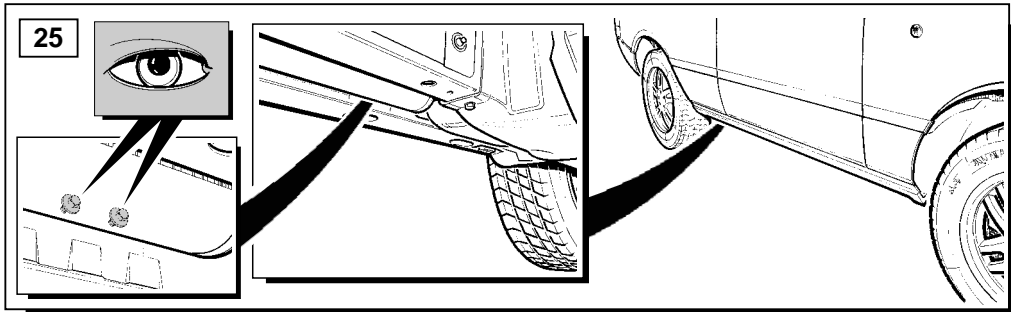

- GB Follow procedures 31 to 34.
- D Befolgen Sie die Anweisungen 31 bis 34.
- F Suivez les procédures 31 à 34.
- I Seguire la procedura da 31 a 34.
- E Siga los procedimientos 31 a 34.
- P Siga os procedimentos 31 a 34.
- NL Volg procedure 31 tot 34.
- GR Ακολουθήστε τις διαδικασίες 31 έως 34.
- 日 手順 31 から 34 に従ってください。

