



ACCESSORIES

WARNING

Accessories which are not properly fitted can be dangerous. Read the instructions carefully prior to fitting. Whilst fitting, comply with the instructions at all times. If in doubt, contact your nearest Land Rover Dealer.

ACHTUNG!

Nicht sachgemäß montiertes Zubehör kann gefährlich sein. Lesen Sie die Montageanleitung sorgfältig, bevor Sie das Teil montieren. Halten Sie sich bei der Montage an die Anleitung. Bei Unsicherheiten wenden Sie sich bitte an Ihren Land Rover Händler.

AVERTISSEMENT

Les accessoires qui ne sont pas correctement montés risquent d'être dangereux. Veuillez lire soigneusement les instructions avant d'effectuer la pose. Respectez toujours les instructions en cours de pose. En cas de doute, consultez votre concessionnaire Land Rover local.

AVVERTENZA

Gli accessori non sistemati come previsto possono essere pericolosi. Leggere attentamente le istruzioni prima del fissaggio. Durante il montaggio seguire sempre le relative istruzioni. In caso di dubbio rivolgersi al più vicino concessionario della Land Rover.

AVISO

Aquellos accesorios que no hayan sido ajustados debidamente pueden resultar peligrosos. Lea las instrucciones detenidamente antes de iniciar el montaje. Durante el montaje siga las instrucciones en todo momento. En caso de duda póngase en contacto con su Concesionario de Land Rover.

ADVERTÊNCIA!

Os Acessórios que não são montados adequadamente podem ser perigosos. Leia as instruções cuidadosamente antes de montar. Durante a montagem, obedeça as instruções todo o tempo. Se tiver alguma dúvida, contacte o Concessionário LandRover mais próximo.

WAARSHCUWING

Accessoires die niet op de juiste wijze zijn gemonteerd kunnen gevaar opleveren. Lees zorgvuldig de instructies alvorens met de montage te beginnen. Houd u tijdens de montage te allen tijde aan de instructies. Neem bij twijfel contact op met de dichtstbijzijnde Land Rover dealer.

ΠΡΟΕΙΔΟΠΟΙΗΣΗ

Τα προαιρετικά εξαρτήματα που δεν έχουν τοποθετηθεί σωστά μπορεί να είναι επικίνδυνα. Διαβάστε τις οδηγίες πριν προχωρήσετε στην τοποθέτησή τους. Κατά την τοποθέτησή, τηρείτε συνεχώς τις οδηγίες. Αν έχετε οποιαδήποτε αμφιβολία, επικοινωνήστε με τον πλησιέστερο αντιπρόσωπο της.

注意

正しく取り付けられていない部品があると、事故の原因になります。取付ける前にこのマニュアルをよくお読みください。取付けの際は必ずこのマニュアルにある指示に従ってください。何か不明な点がございましたら、お近くのランド・ローバー社のディーラーまでお問い合わせください。



FITTING INSTRUCTION

Towing Kit

EINBAUANLEITUNG

Einbausatz Anhängervorrichtung

INSTRUCTION DE MONTAGE

Lot de dispositif d'attelage

ISTRUZIONI PER L'USO

Kit di montaggio per dispositivo di trancio

INSTRUCCIONES DE MONTAJE

Juego de montaje para dispositivo de remolque

INSTRUÇÕES DE MONTAGEM

Jogo de montagem para esfera de acoplamento de reboque

MONTAGEHANDLEIDING

Set de montage voor trekhaak

ΟΔΗΓΙΑ ΤΟΠΟΘΕΤΗΣΗΣ

Κιτ Ρυμούλκησης

取付用マニュアル
牽引キット

DEFENDER



MOTOR VEHICLE DATA (GB)

Manufacturer - Land Rover Ltd
Official Motor Type - LD
Model - DEFENDER 110 from 1999

TOW BAR INCLUDING BRACKET - DATA

Coupling class - A
Approval number - e11 00 1204
D-Value - 17.4 kN
S-Value - 250 kg
Max Trailer Weight - 3500 kg (NOTE! refer to handbook for gross trainweight.)

DONNEES - VEHICULE AUTOMOBILE (F)

Constructeur - Land Rover Ltd
Type de moteur officiel - LD
Modèle - DEFENDER 110 à partir de 1999

DONNEES - BARRE DE REMORQUAGE, SUPPORT INCLUS

Classe d'accouplement - A
Numéro d'homologation - e11 00 1204
Valeur-D - 17.4kN
Valeur-S - 250 kg
Poids de remorque maximum - 3500 kg (NOTA: Se reporter au manuel pour le poids de train brut)

DATOS DEL COCHE (E)

Fabricante - Land Rover Limited
Tipo oficial de coche - LD
Modelo - DEFENDER 110 desde 1998

BARRA DE REMOLQUE INCLUIDO EL SOPORTE - DATOS

Clase de acoplamiento - A
Número de aprobación - e11 00 1204
Valor-D - 17.4 kN
Valor-S - 250 kg
Peso máximo del remolque - 3500 kg (NOTA: Consultar el manual para el peso bruto del tren).

VOERTUIGSPECIFICATIES (NL)

Fabrikant - Land Rover Ltd
Officieel motortype - LD
Model - DEFENDER 110 vanaf 1999

TREKHAAK INCLUSIEF STEUN - SPECIFICATIES

Koppingsklasse - A
Homologatienummer - e11 00 1204
D-waarde - 17.4 kN
S-waarde - 250 kg
Max. toelaatbaar aanhangwagengewicht - 3500 kg (N.B.Raadpleeg het instructieboek je voor maximaal toelaatbaar treingewicht.)

FAHRZEUGDATEN (D)

Hersteller - Land Rover Limited
Offizieller Motortyp - LD
Modell - DEFENDER 110 ab 1999

ANHÄNGERKUPPLUNG MIT HALTERUNG - DATEN

Kupplungsklasse - A
Zulassungsnummer - e11 00 1204
D-Wert - 17.4 kN
S-Wert - 250 kg
Maximales Anhängergewicht - 3500 kg (Beachte: Höchstzulässiges Gesamtgewicht im Handbuch beachten!)

DATI PER L' AUTOVEICOLO (I)

Fabbricante: - Land Rover Ltd
Tipo ufficiale di motore: - LD
Modello: - DEFENDER 110 dal 1999

BARRA DI TRAINO COMPRESA SQUADRETTA - DATI

Classe di accoppiamento - A
Numero di approvazione - e11 00 1204
Valore D - 17.4 kN
Valore S - 250 kg
Peso massimo del rimorchio - 3500 kg (NOTA! Per il peso lordo del rimorchio consultare il manuale.)

DADOS DE VEÍCULOS A MOTOR (P)

Fabricante - Land Rover Ltd
Tipo de Motor Oficial - LD
Modelo - DEFENDER 110 de 1999

BARRA DE REBOQUE INCLUINDO SUPORTE - DADOS

Classe de acoplamento - A
Número de aprovação - e11 00 1204
Valor D - 17.4 kN
Valor S - 250 kg
Peso máximo de reboque - 3500 kg (NOTA! consulte o manual para o peso bruto de trem).

ΣΤΟΙΧΕΙΑ ΟΧΗΜΑΤΟΣ (GR)

Κατασκευαστής - Land Rover Ltd
Επίσημος Τύπος Κινητήρα - LD
Μοντέλο - DEFENDER 110 μετά το 1999

ΡΑΒΔΟΣ ΡΥΜΟΥΑΚΗΣΗΣ ΜΕ ΑΓΚΙΣΤΡΟ - ΣΤΟΙΧΕΙΑ

Κατηγορία ζεύξης - A
Αριθμός έγκρισης - e11 00 1204
Τιμή D - 17.4 kN
Τιμή S - 250 κιλά
Μέγιστο Βάρος Ρυμούακας - 3500 κιλά (ΣΗΜΕΙΩΣΗ! Για το συνολικό μικ το βάρος, ανατρέξτε στο εγχειρίδιο)

自動車データ (日)

製造業者 - Land Rover Ltd
公式モータータイプ - LD
モデル - 1999 年以降の - DEFENDER 110
ブラケット付き牽引バー -

カップリング クラス - A
承認番号 - e11 00 1204
D 値 - 17.4kN
S 値 - 250kg
最大トレーラー重量 - 3500kg (注意! 総トレーン重量については、ノートブック参照)

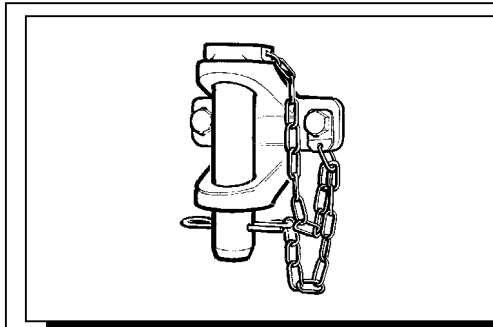

KNB 100640

e11 00 0676

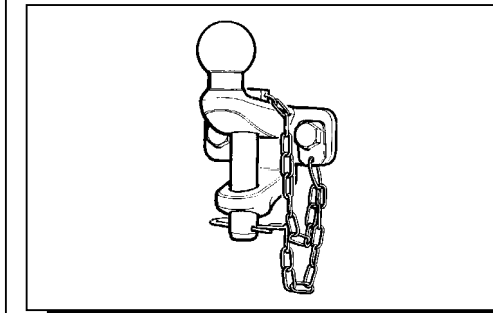

RTC 8159

e11 00 0648

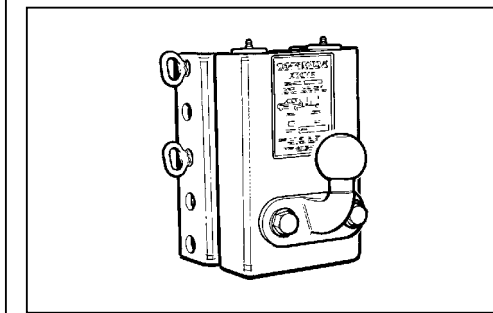

STC 7669

e11 00 0776

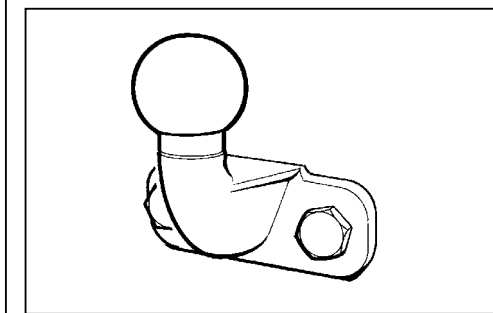

RTC 8891AA

