



ACCESSORIES

WARNING

Accessories which are not properly fitted can be dangerous. Read the instructions carefully prior to fitting. Whilst fitting, comply with the instructions at all times. If in doubt, contact your nearest Land Rover Dealer.

ACHTUNG!

Nicht sachgemäß montiertes Zubehör kann gefährlich sein. Lesen Sie die Montageanleitung sorgfältig, bevor Sie das Teil montieren. Halten Sie sich bei der Montage an die Anleitung. Bei Unsicherheiten wenden Sie sich bitte an Ihren Land Rover Händler.

AVERTISSEMENT

Les accessoires qui ne sont pas correctement montés risquent d'être dangereux. Veuillez lire soigneusement les instructions avant d'effectuer la pose. Respectez toujours les instructions en cours de pose. En cas de doute, consultez votre concessionnaire Land Rover local.

AVVERTENZA

Gli accessori non sistemati come previsto possono essere pericolosi. Leggere attentamente le istruzioni prima del fissaggio. Durante il montaggio seguire sempre le relative istruzioni. In caso di dubbio rivolgersi al più vicino concessionario della Land Rover.

AVISO

Aquellos accesorios que no hayan sido ajustados debidamente pueden resultar peligrosos. Lea las instrucciones detenidamente antes de iniciar el montaje. Durante el montaje siga las instrucciones en todo momento. En caso de duda póngase en contacto con su Concesionario de Land Rover.

ADVERTÊNCIA!

Os Acessórios que não são montados adequadamente podem ser perigosos. Leia as instruções cuidadosamente antes de montar. Durante a montagem, obedeça as instruções todo o tempo. Se tiver alguma dúvida, contacte o Concessionário LandRover mais próximo.

WAARSHCUWING

Accesoires die niet op de juiste wijze zijn gemonteerd kunnen gevaar opleveren. Lees zorgvuldig de instructies alvorens met de montage te beginnen. Houd u tijdens de montage te allen tijde aan de instructies. Neem bij twijfel contact op met de dichtstbijzijnde Land Rover dealer.

ΠΡΟΕΙΔΟΠΟΙΗΣΗ

Τα προαιρετικά εξαρτήματα που δεν έχουν τοποθετηθεί σωστά μπορεί να είναι επικίνδυνα. Διαβάστε τις οδηγίες πριν προχωρήσετε στην τοποθέτησή τους. Κατά την τοποθέτησή, τηρείτε συνεχώς τις οδηγίες. Αν έχετε οποιαδήποτε αμφιβολία, επικοινωνήστε με τον πλησιέστερο αντιπρόσωπο της.

注意

正しく取り付けられていない備品があると、事故の原因になります。取付ける前にこのマニュアルをよくお読みください。取付けの際は必ずこのマニュアルにある指示に従ってください。何か不明な点がありましたら、お近くのランド・ローバー社のディーラーまでお問い合わせください。

ПРЕДУПРЖДЕНИЕ

Принадлежности, не подогнанные должным образом, могут быть опасными. Внимательно читайте инструкции перед подгонкой. При подгонке всегда соблюдайте инструкции. В случае сомнений обратитесь к ближайшему дилеру Land Rover.

警告：

非正确安装的附件会造成危险。请在安装前认真研读使用手册。安装时，请完全按照使用手册的指示来操作。如有疑问，请与你最近的路虎经销商取得联系。



FITTING INSTRUCTION

Driving Lamp Kit

EINBAUANLEITUNG

Fahrscheinwerfersatz

INSTRUCTION DE MONTAGE

Kit de phares-route

ISTRUZIONI PER L'USO

Corredo fari di guida

INSTRUCCIONES DE MONTAJE

Kit de faros de conducción

INSTRUÇÕES DE MONTAGEM

Kit de Faróis de Condução

MONTAGEHANDLEIDING

Verstralerset

ΟΔΗΓΙΑ ΤΟΠΟΘΕΤΗΣΗΣ

Kit Φώτων Πορείας

取付用マニュアル

ドライビングランプキット

ИНСТРУКЦИИ ПО УСТАНОВКЕ

Дополнительные передние фары

安装说明

驾驶灯套件

VPLAV0019

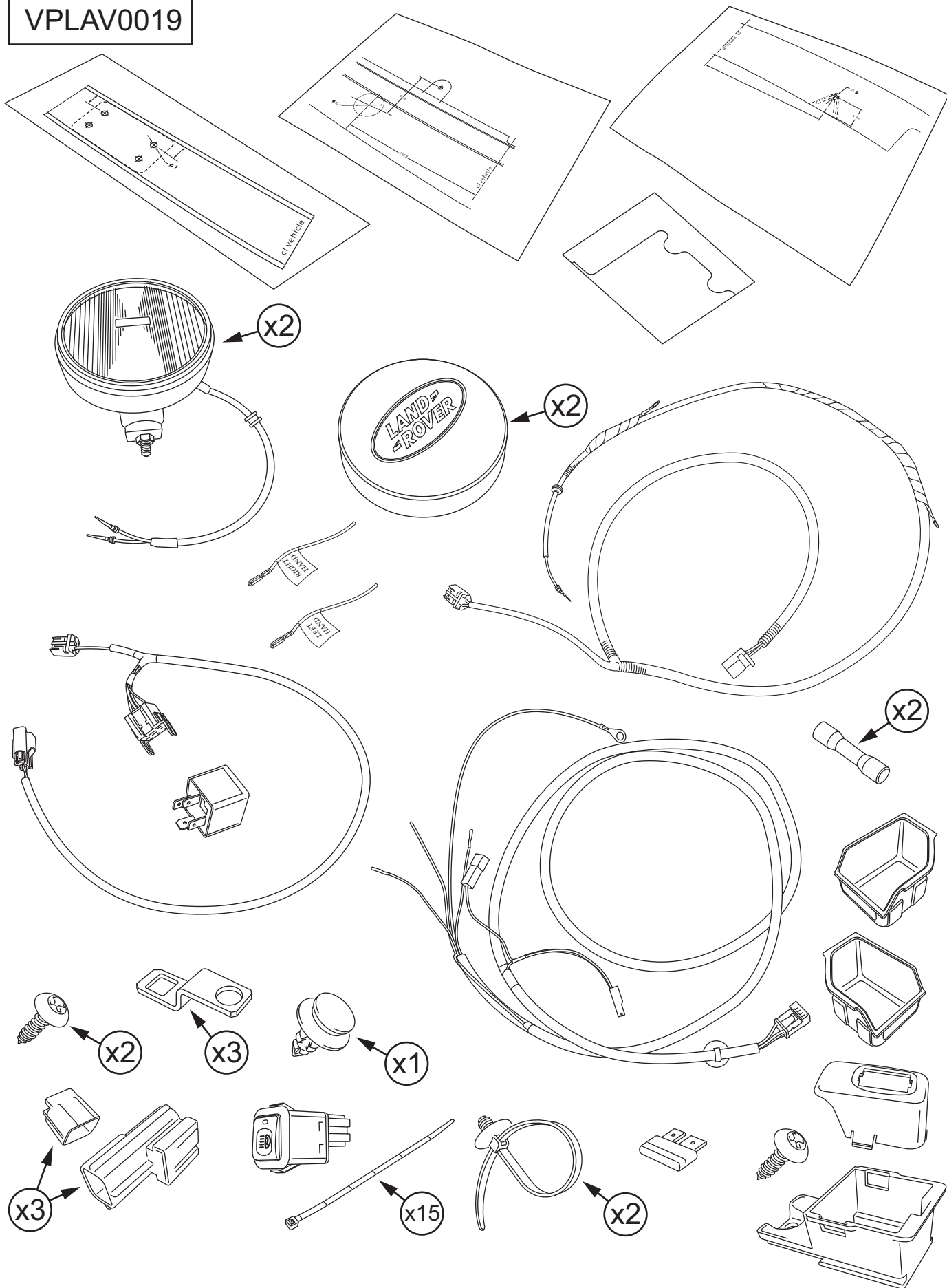

VPLAV0020

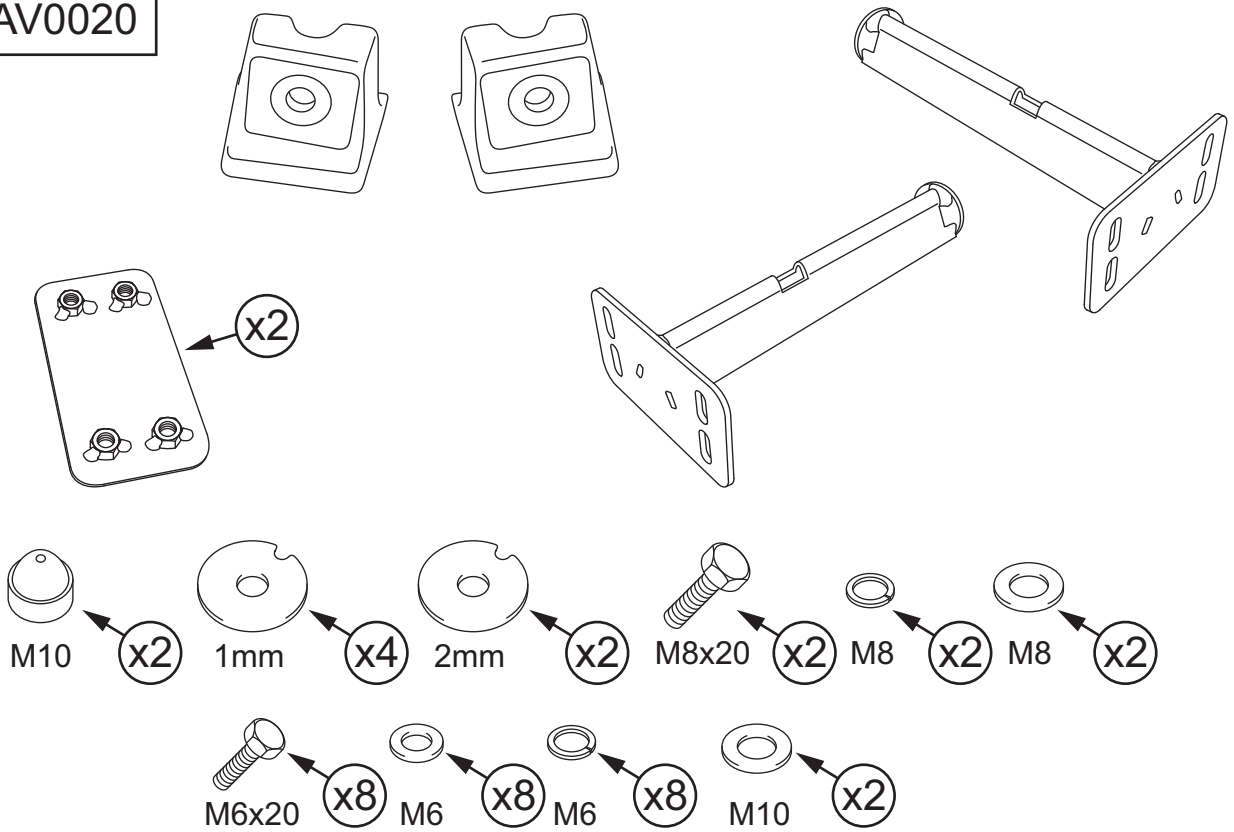

VPLAV0021

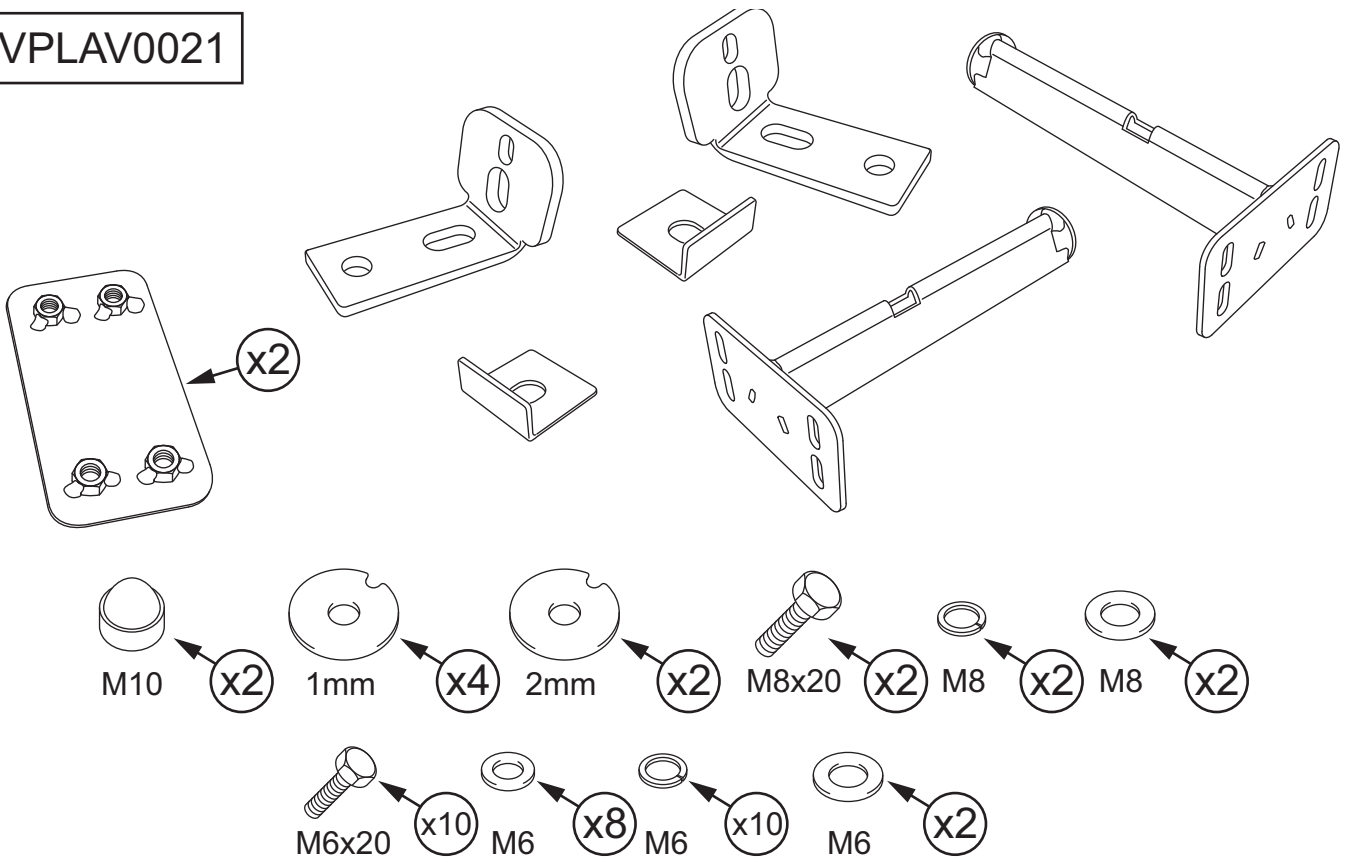

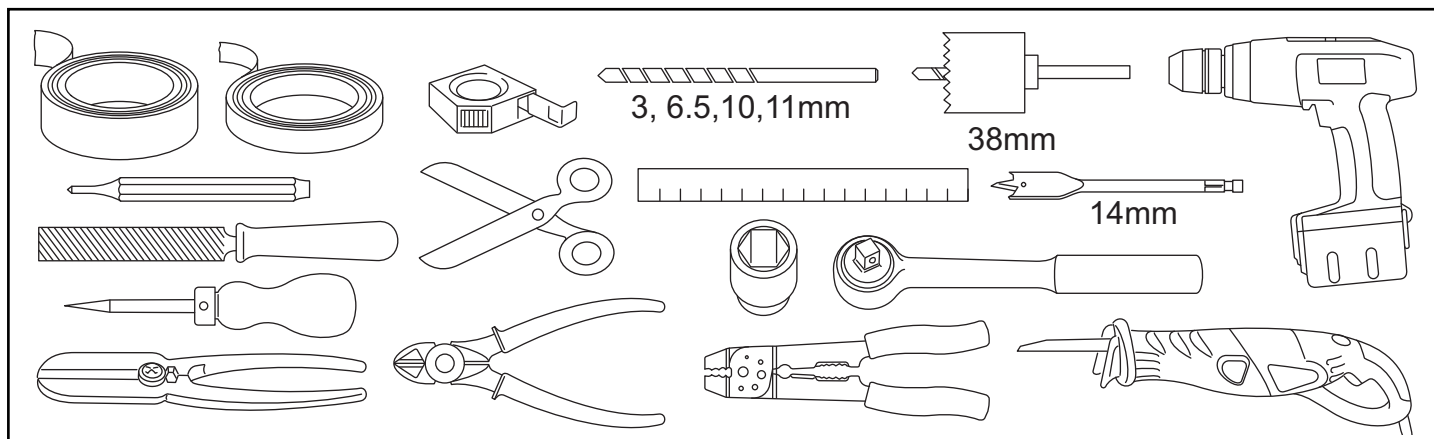

GB Right Hand Drive Shown

D Rechtslenker abgebildet

F Illustration pour véhicule avec volant à droite

I Guida a destra

E Para volante a la izquierda.

P É apresentado um veículo com volante à direita

NL Besturing aan de rechterzijde weergegeven.

GR Στην εικόνα φαίνεται δεξιότιμονο όχημα.

日 右ハンドル車仕様

SU Показан правый привод

国語 右座驾驶如图。

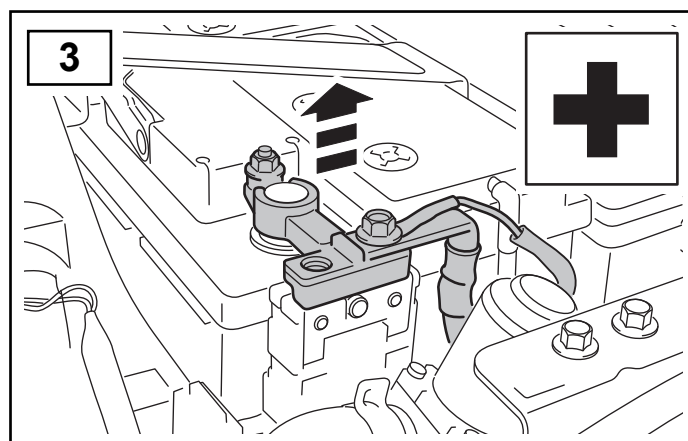
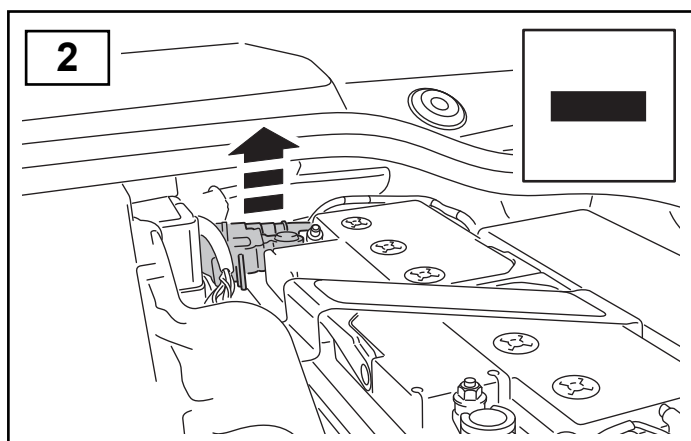
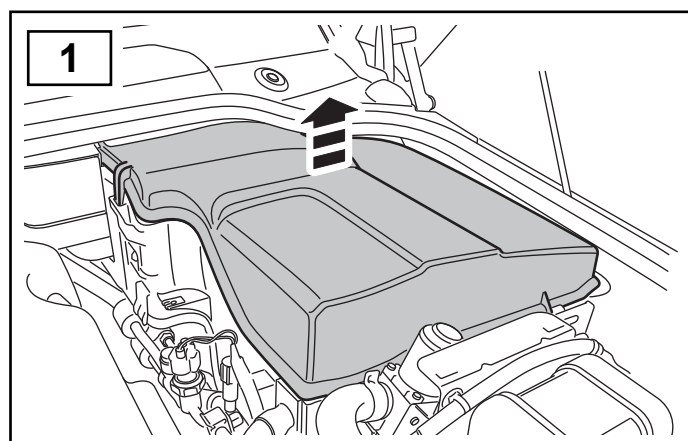
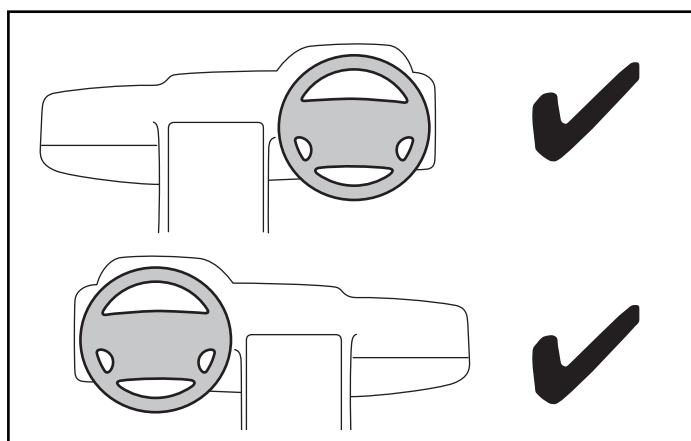

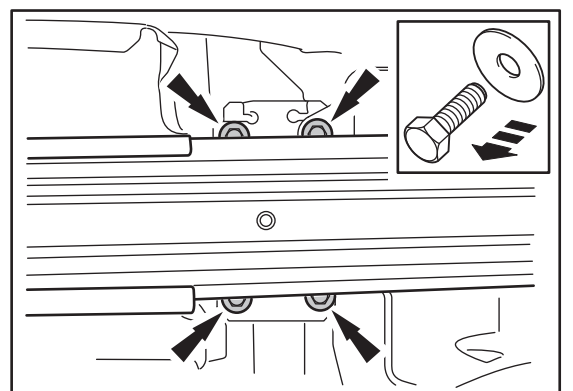
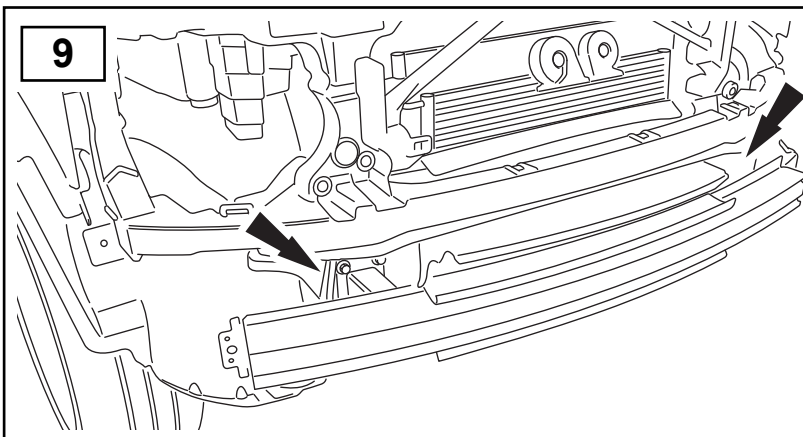
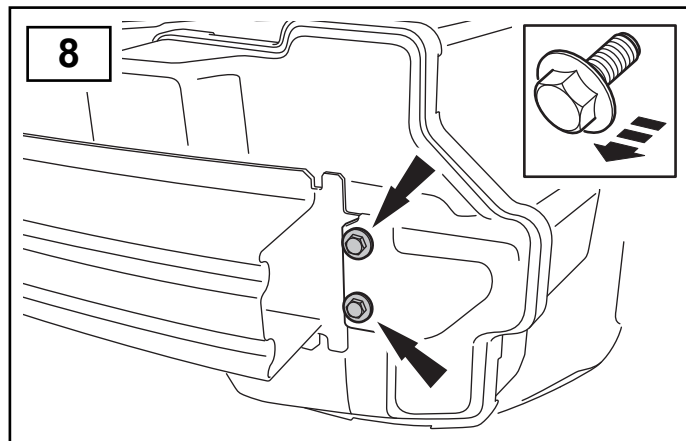
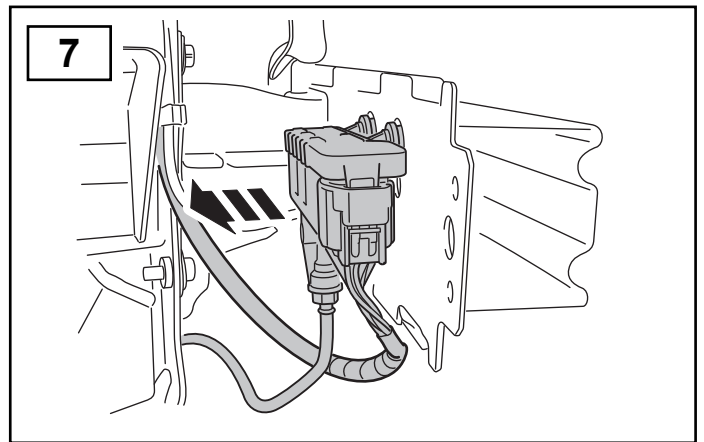
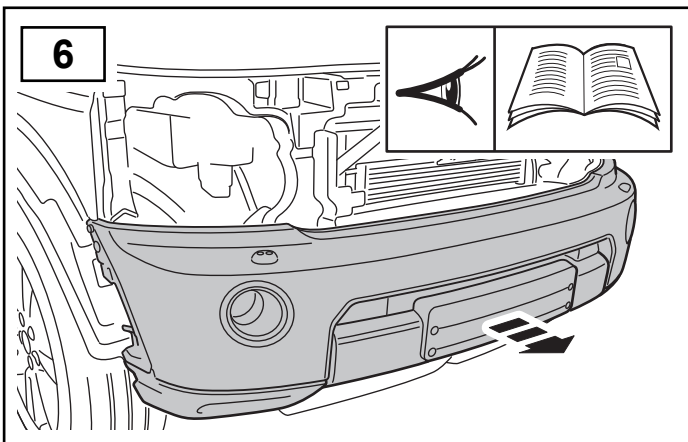
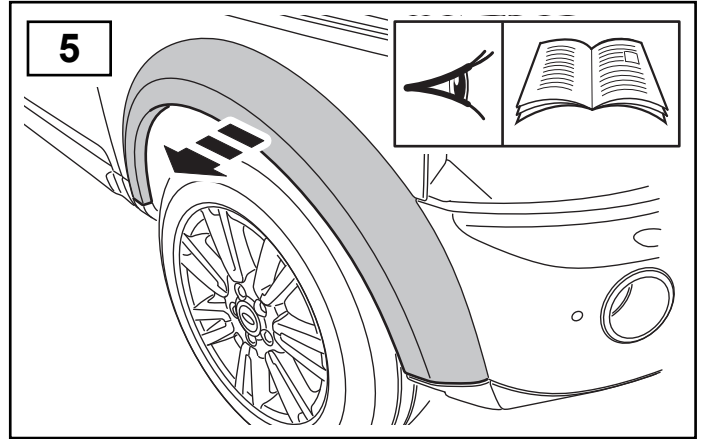
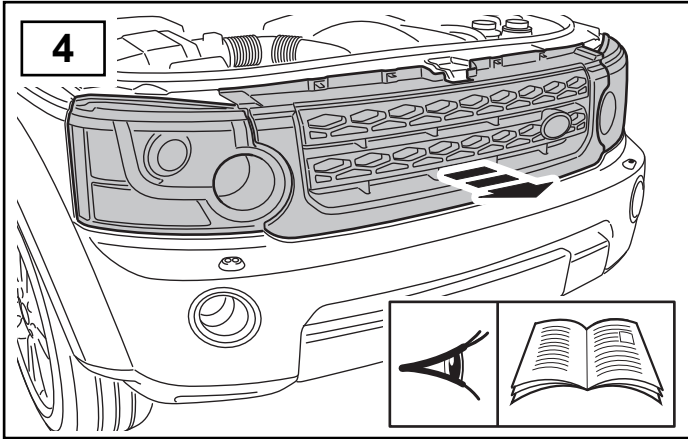

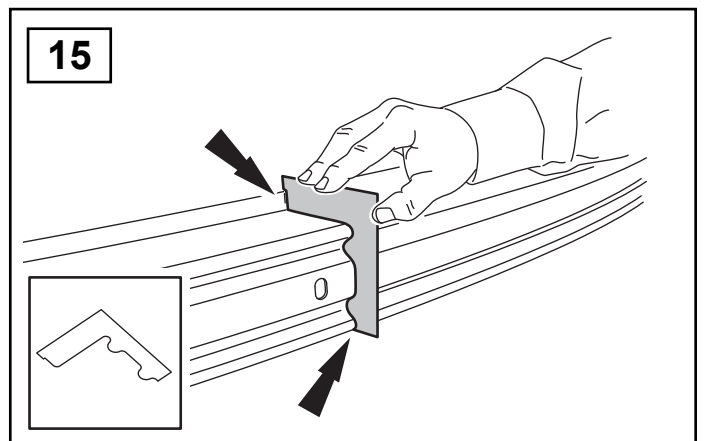
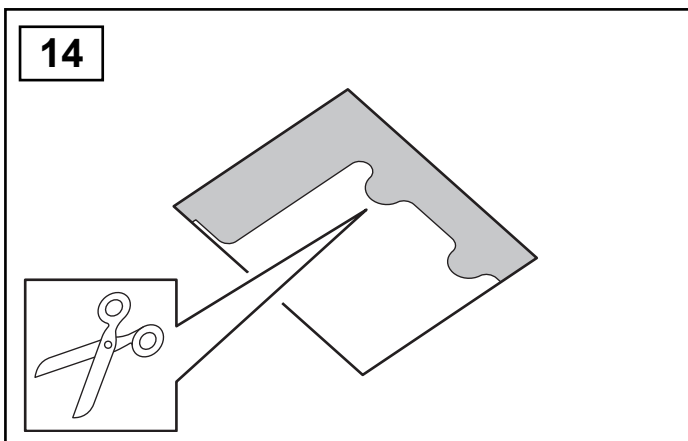
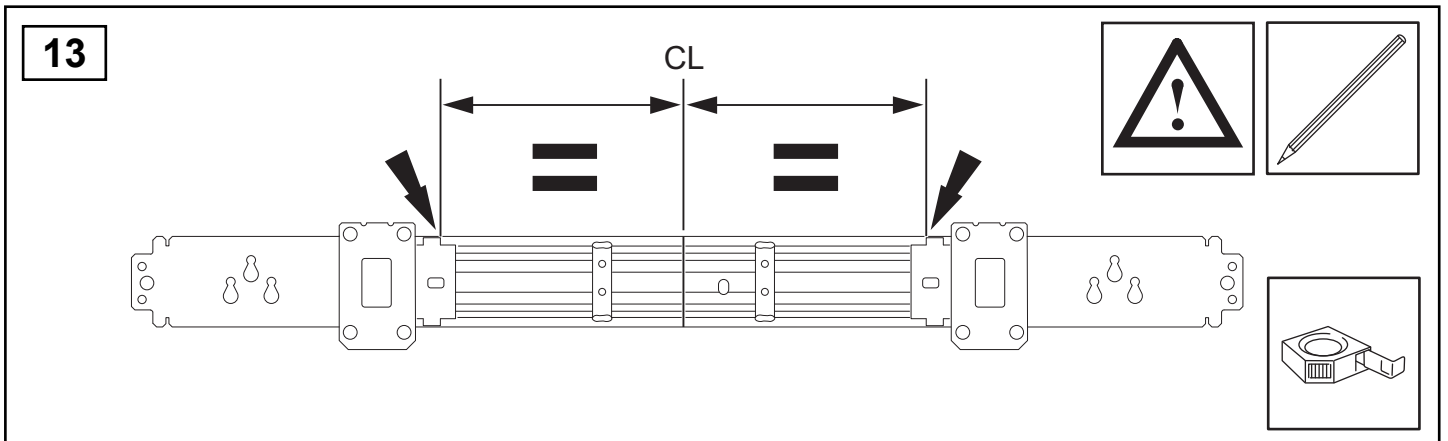
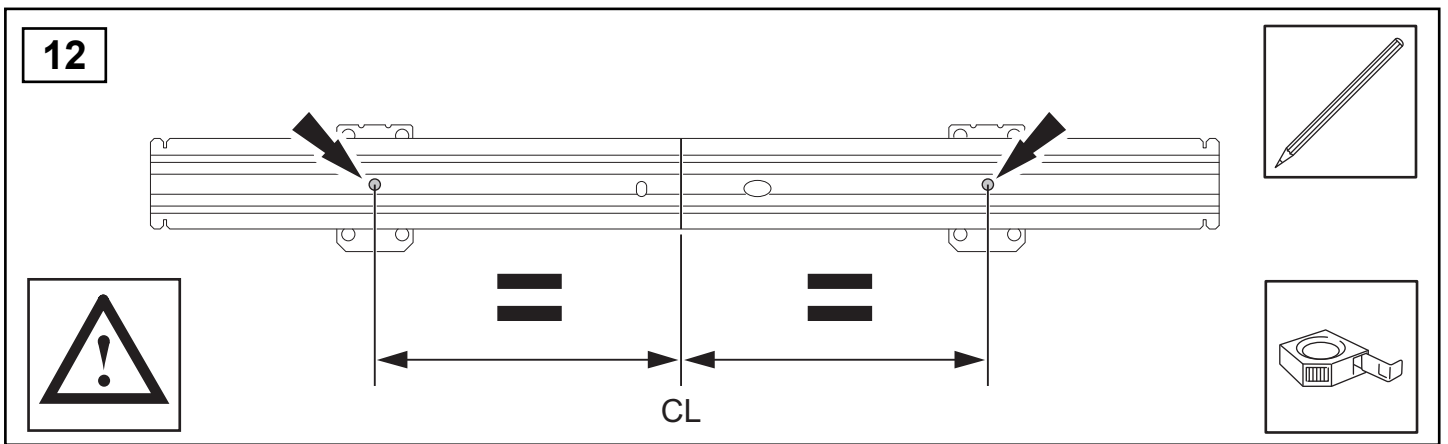
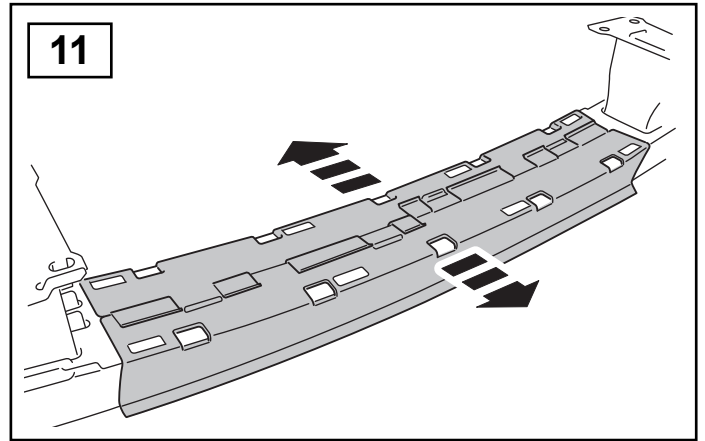
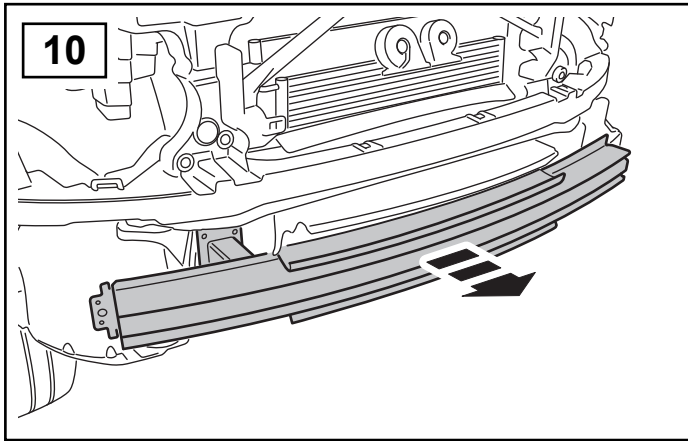

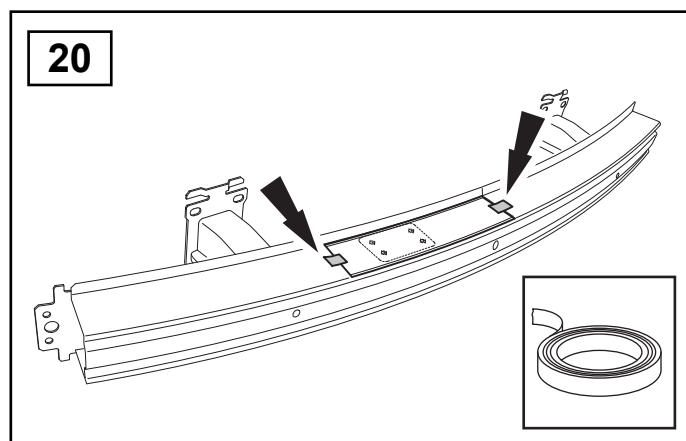
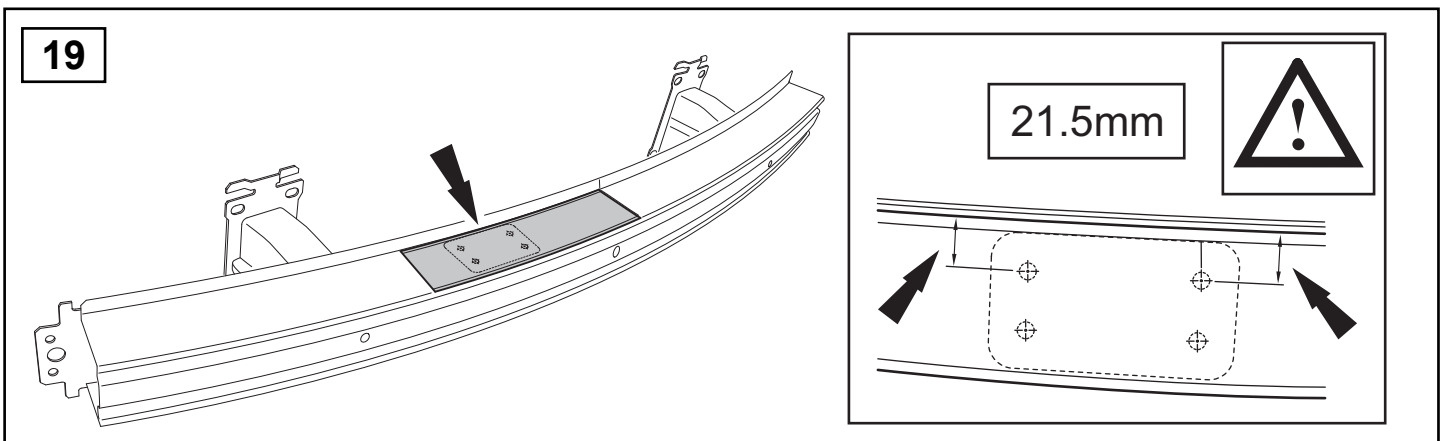
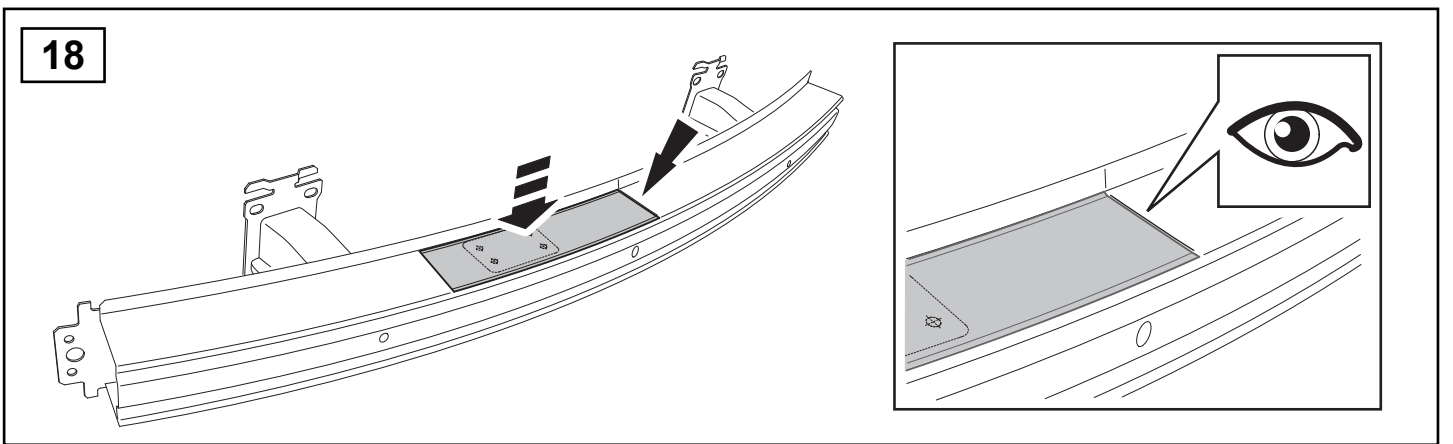
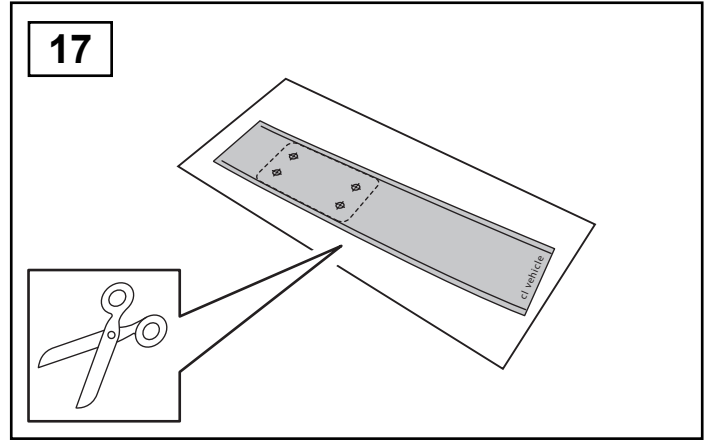
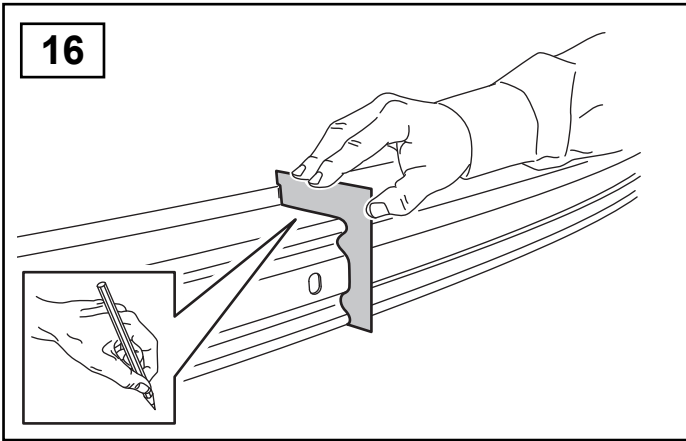

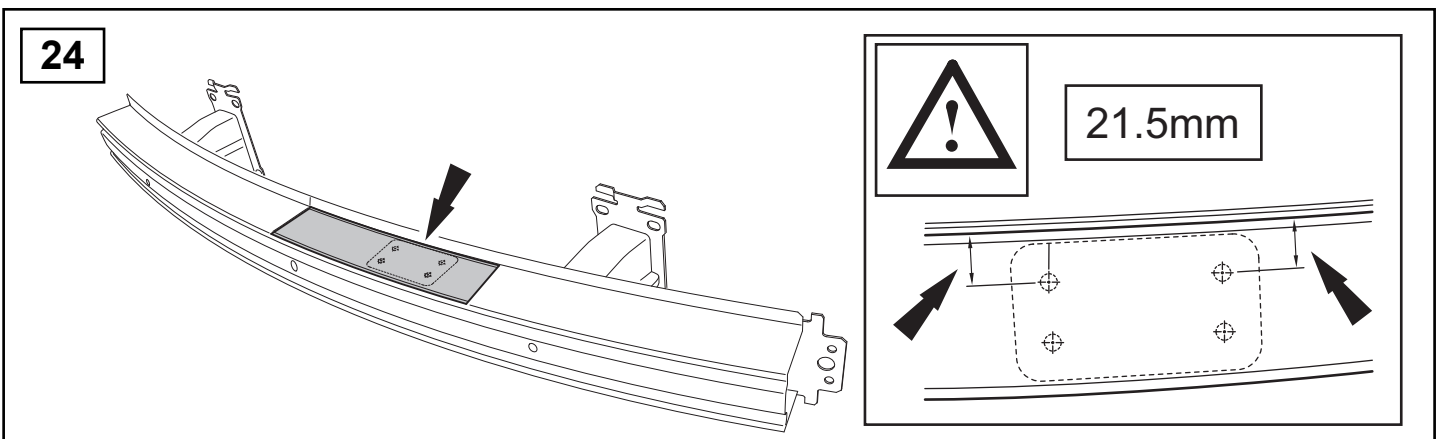
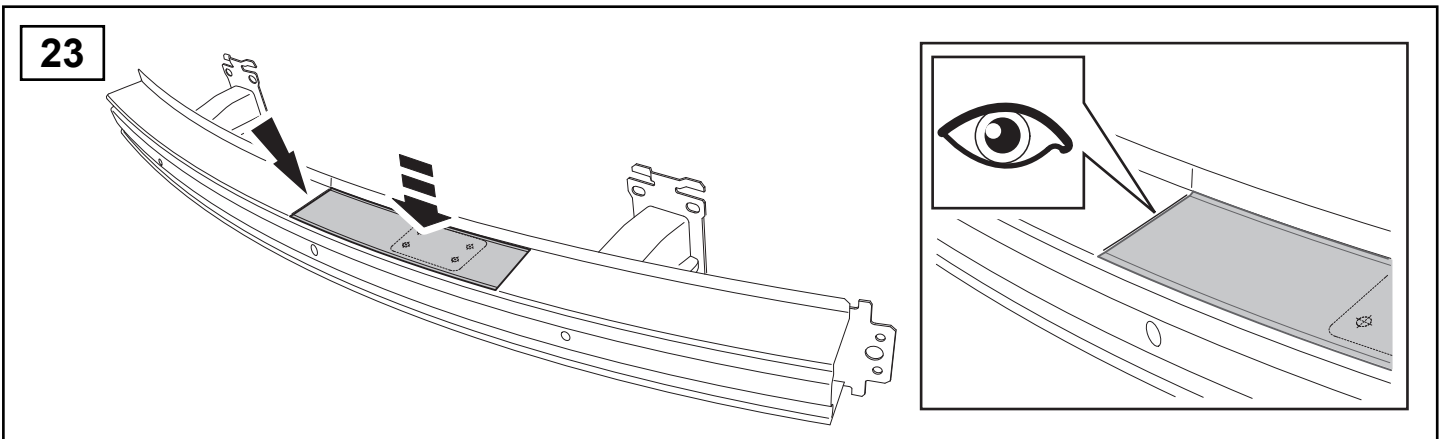
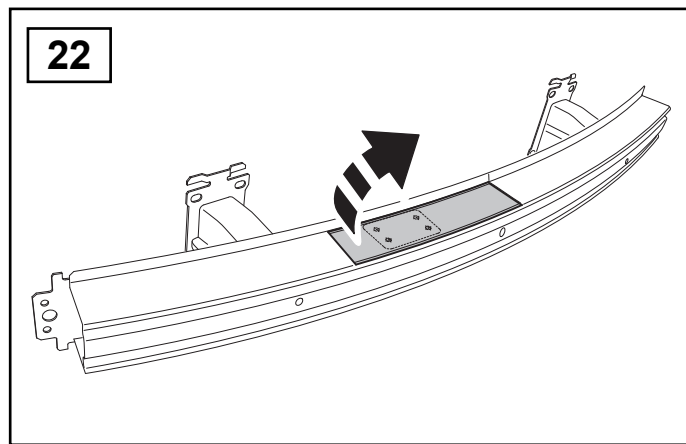
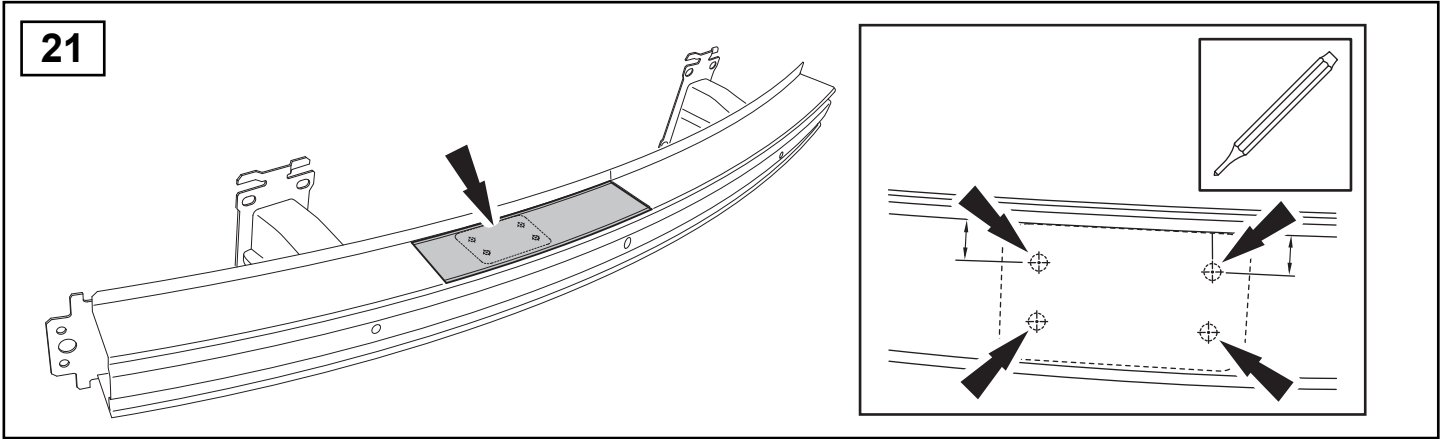

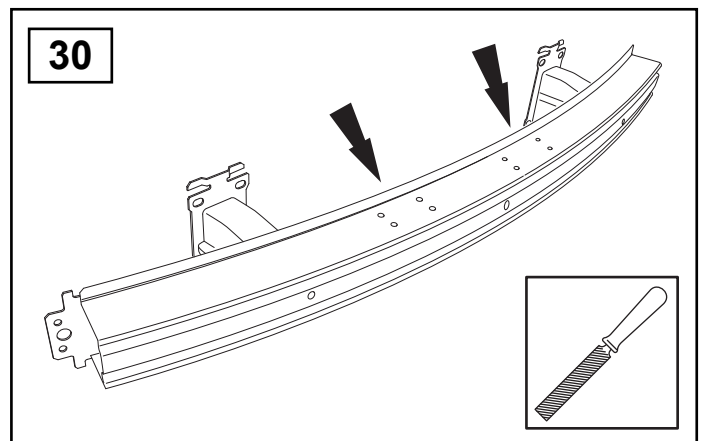
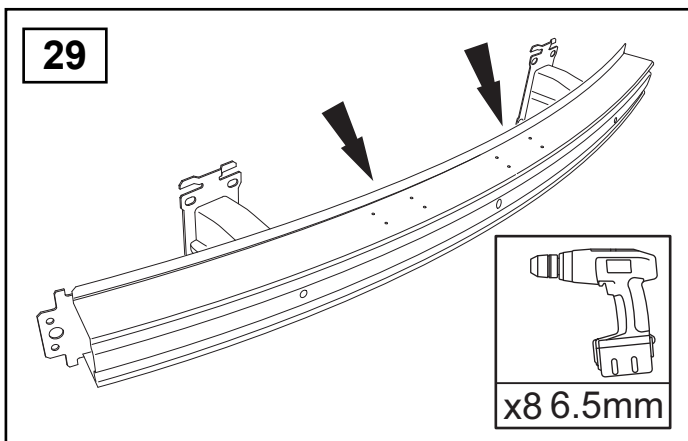
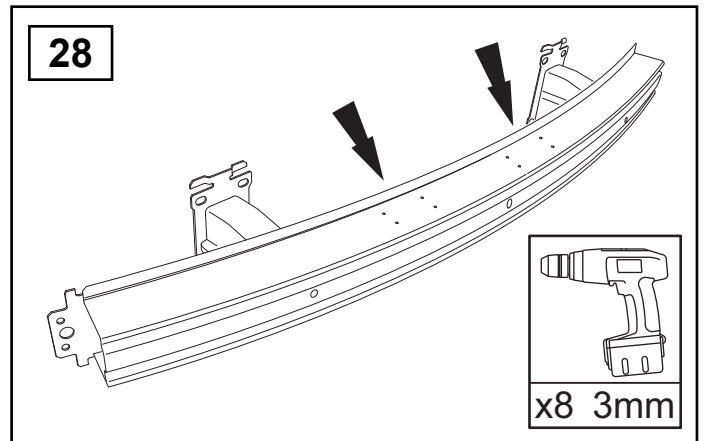
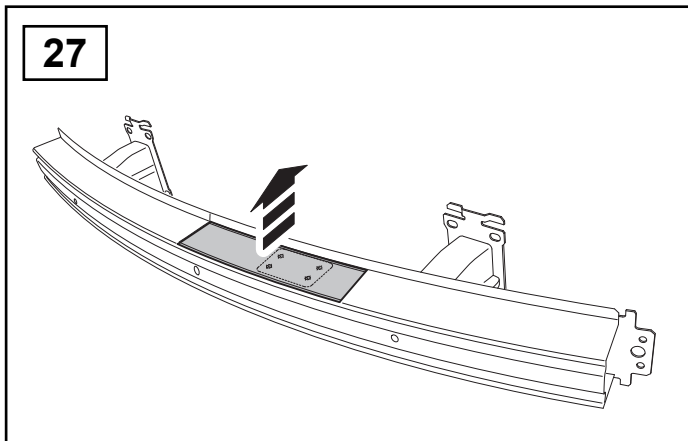
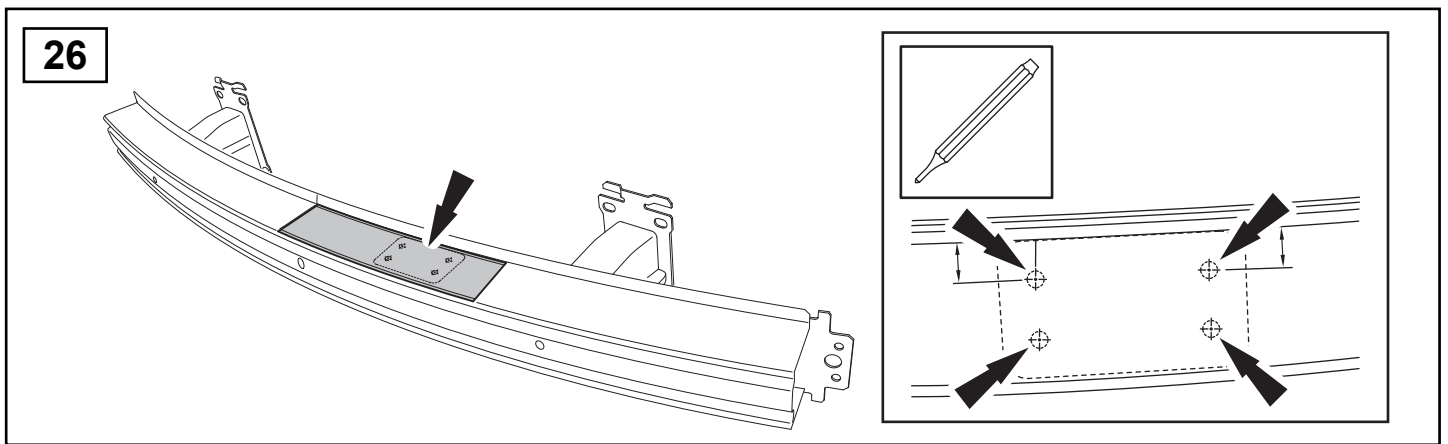
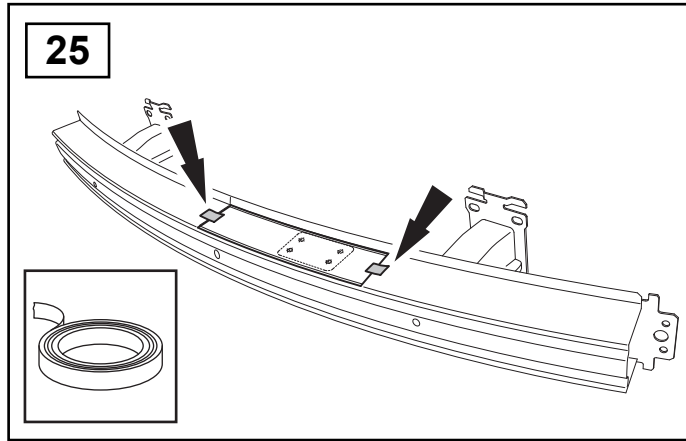

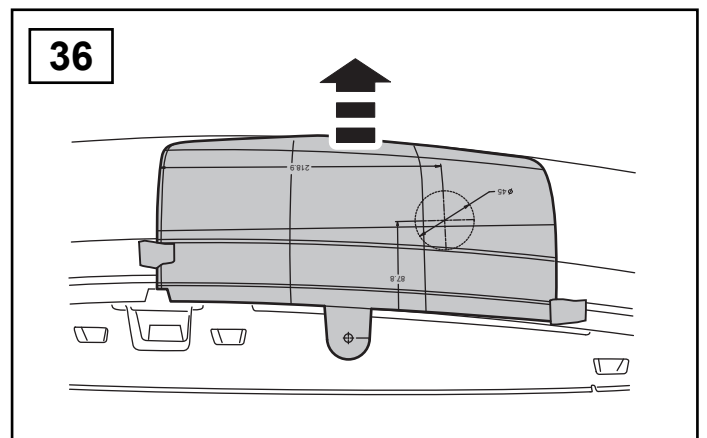
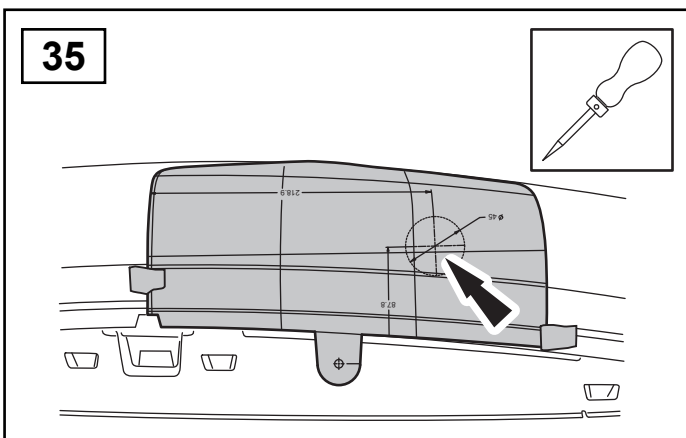
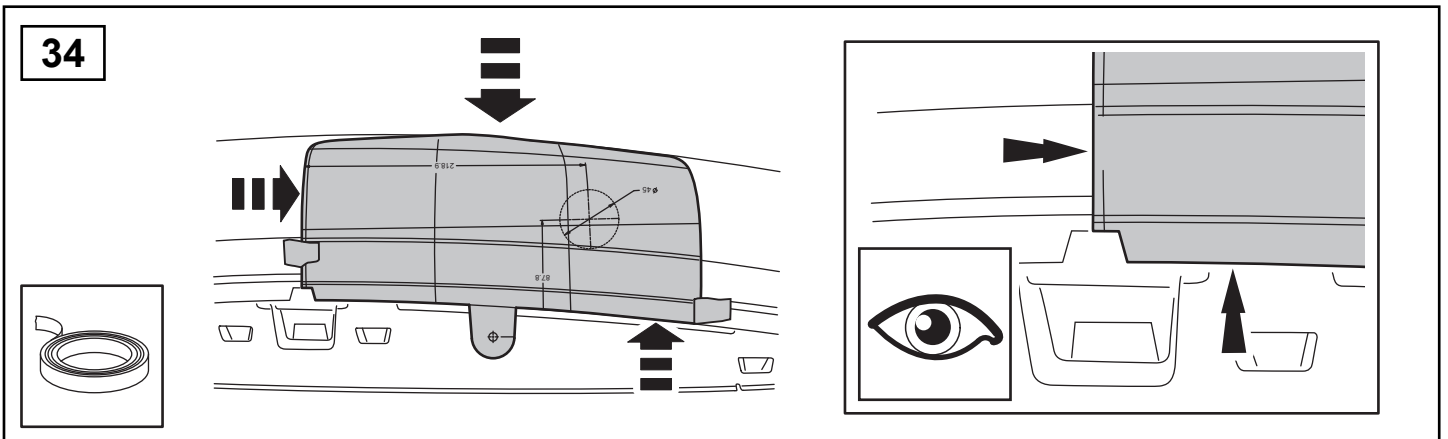
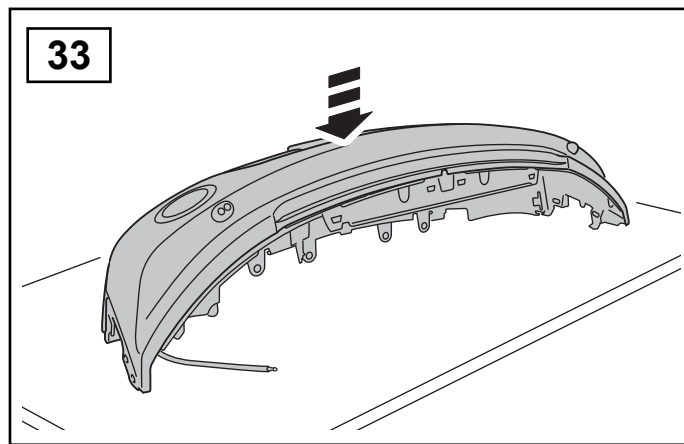
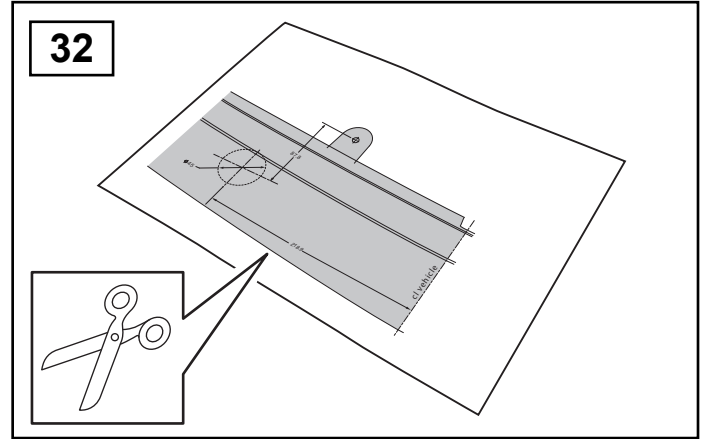
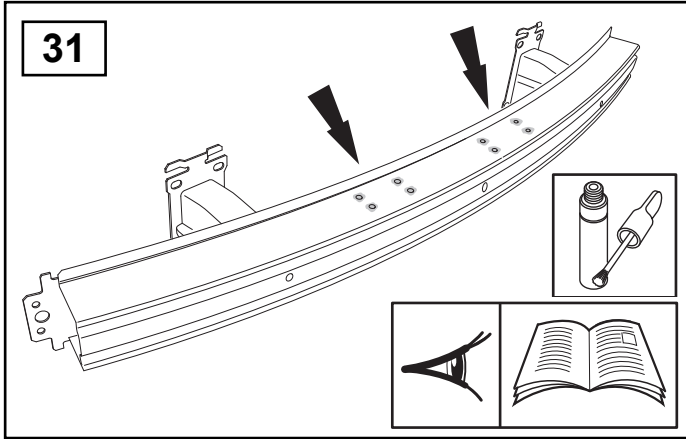

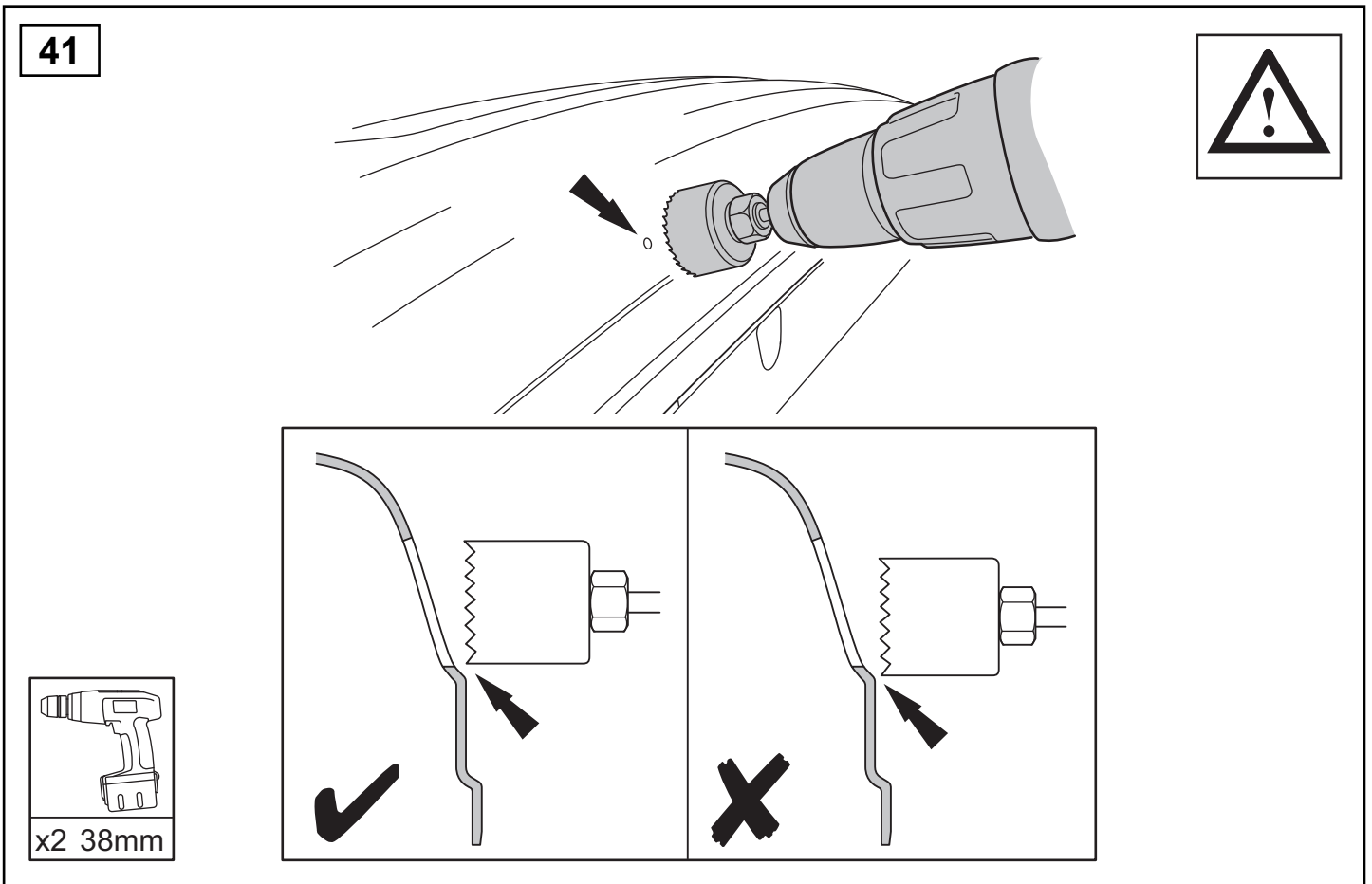
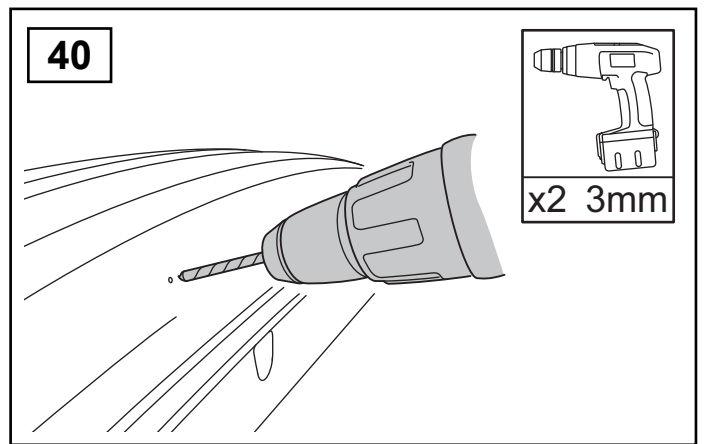
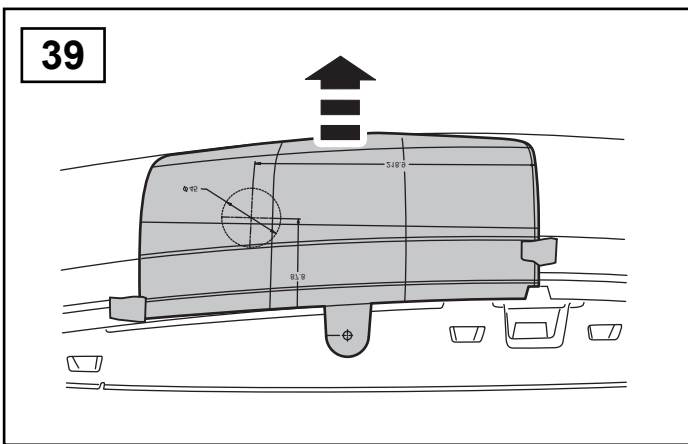
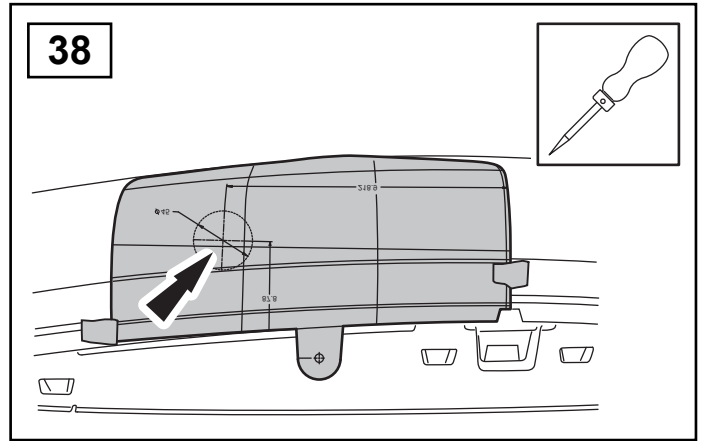
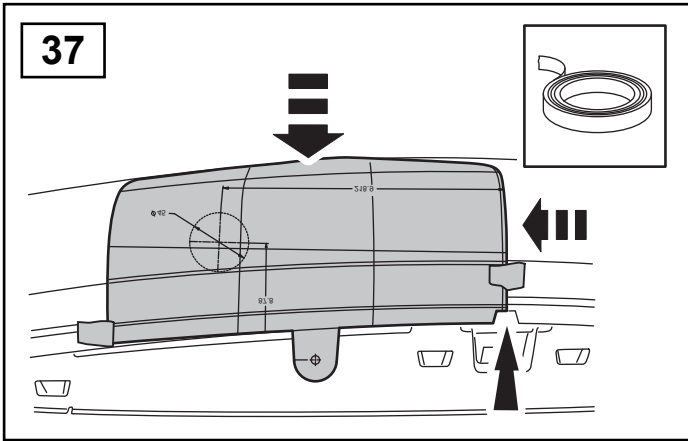

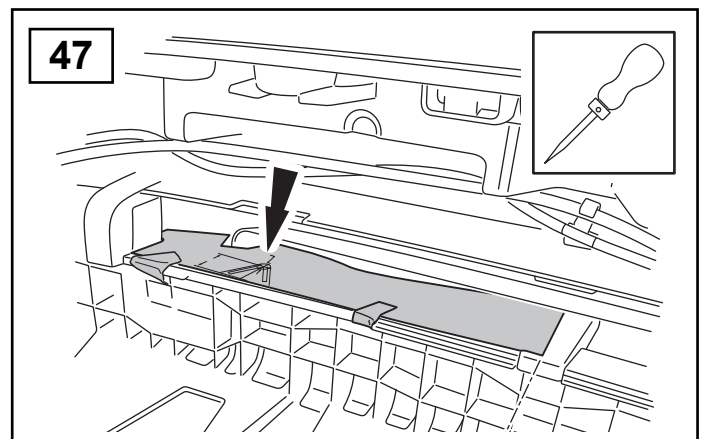
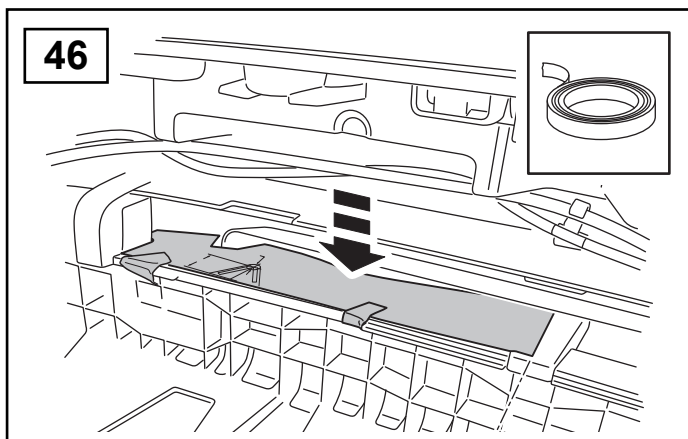
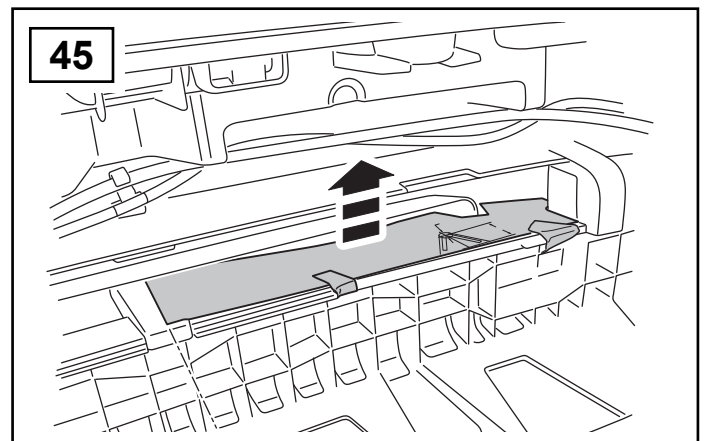
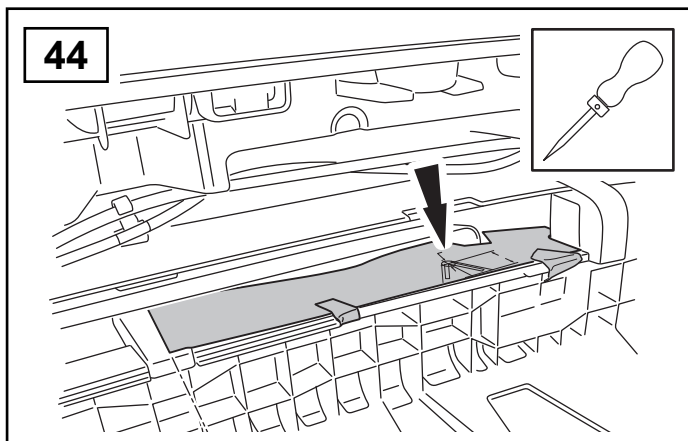
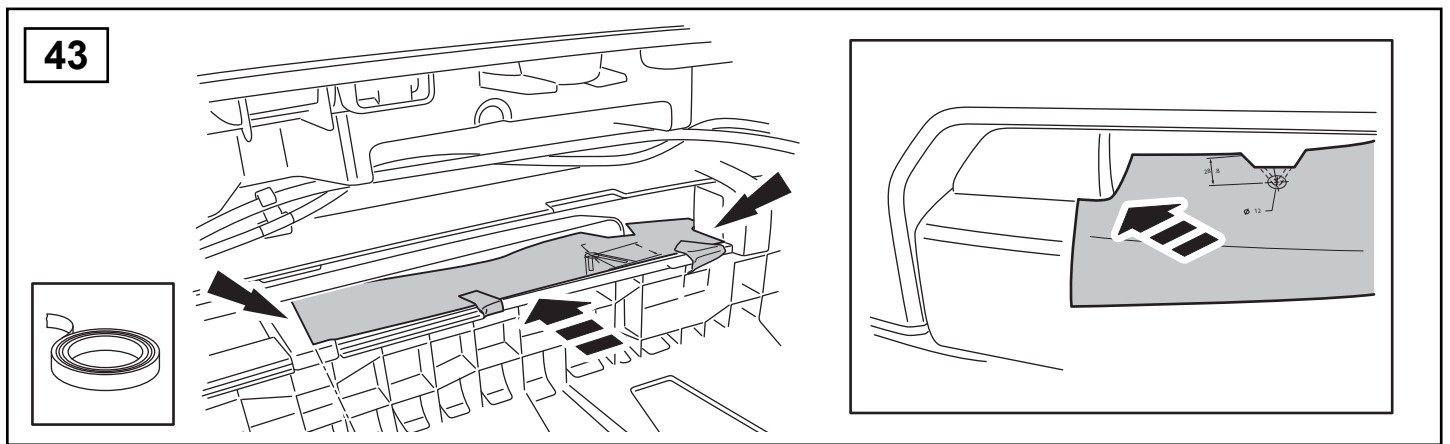
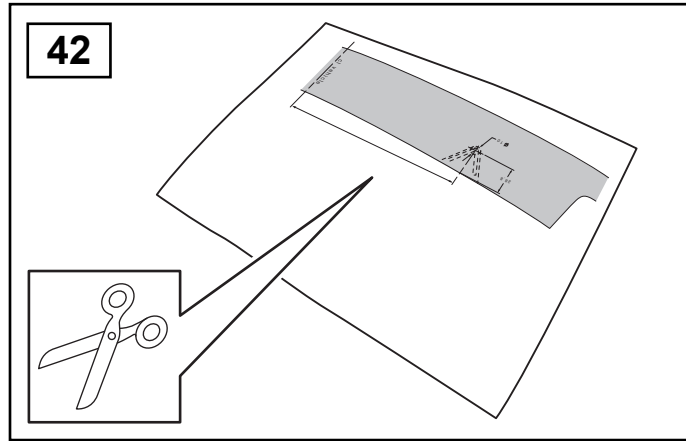

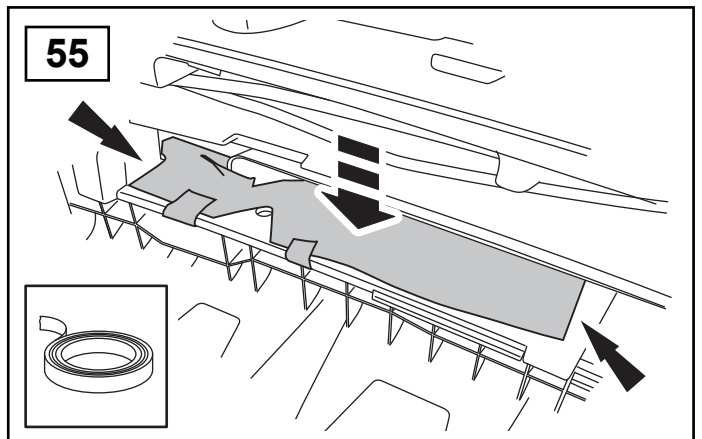
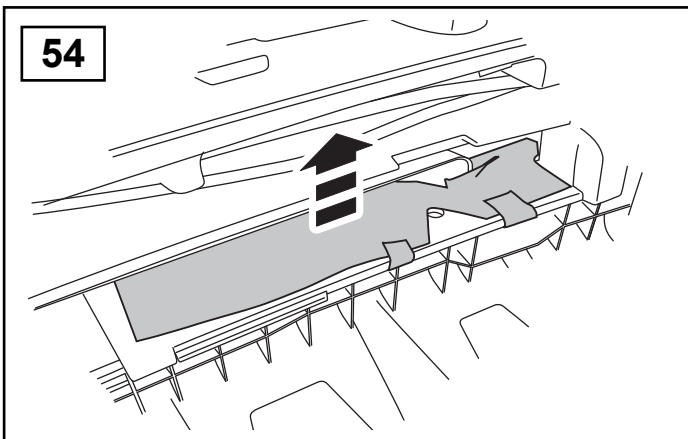
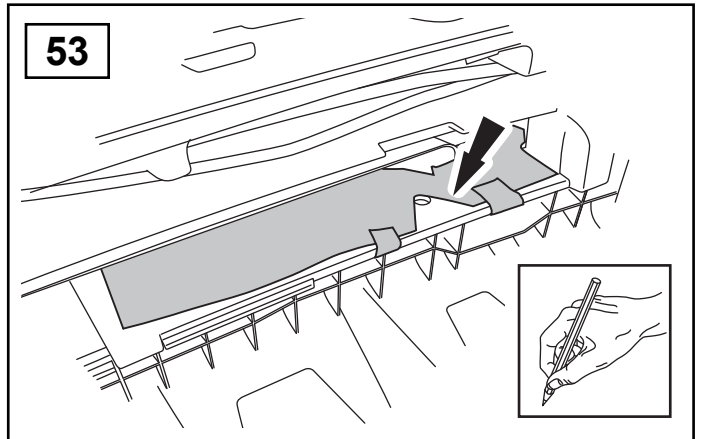
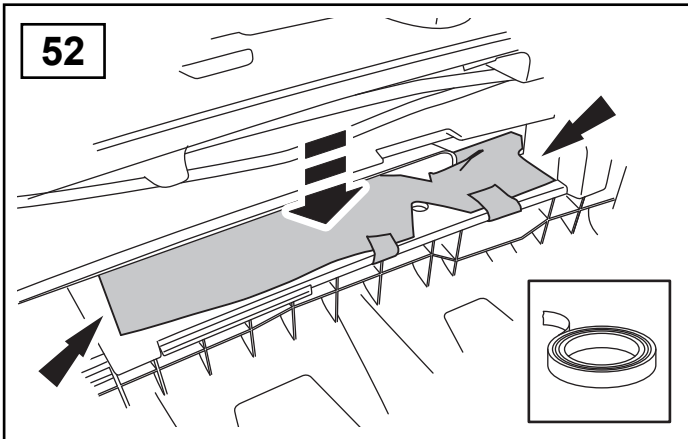
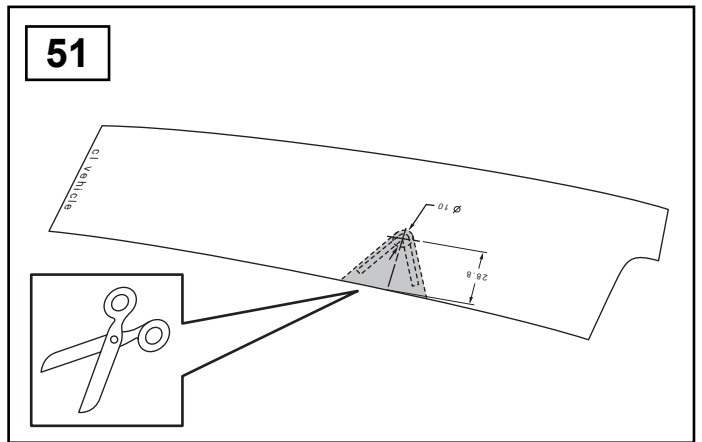
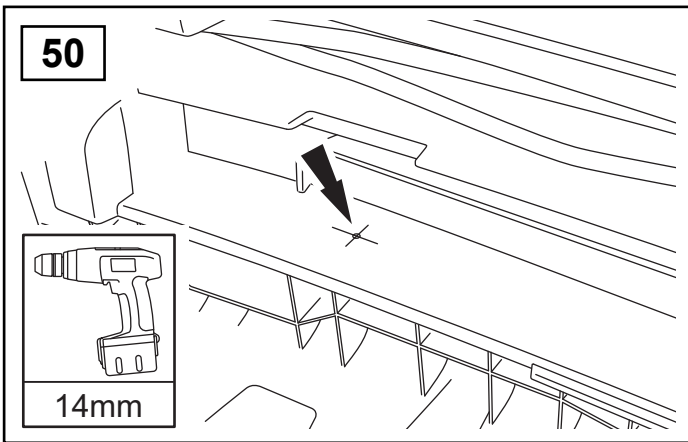
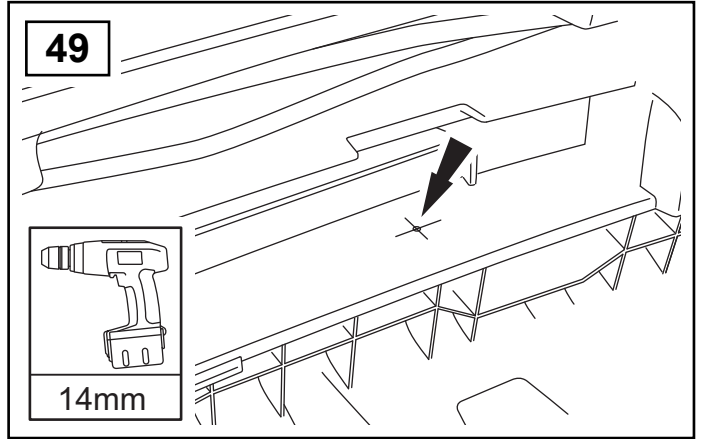
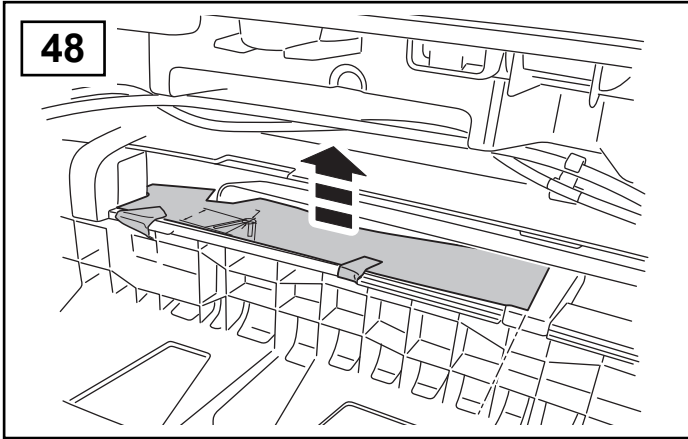

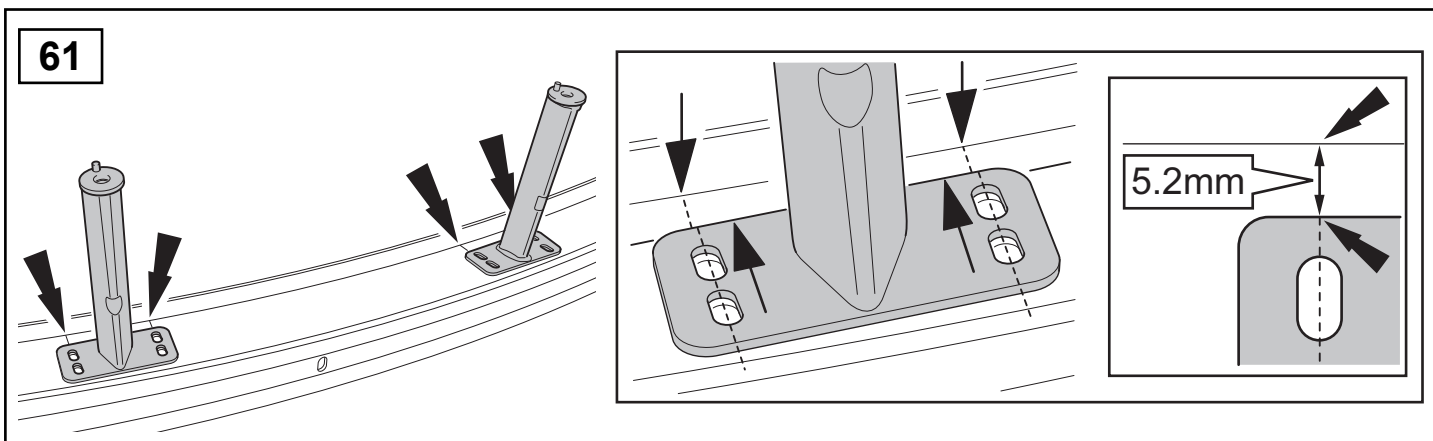
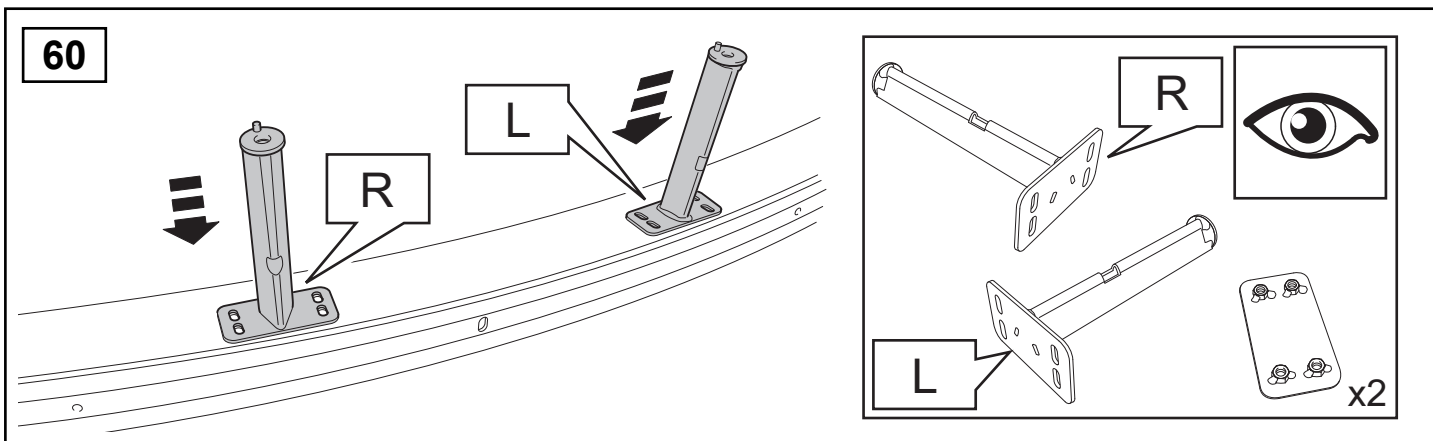
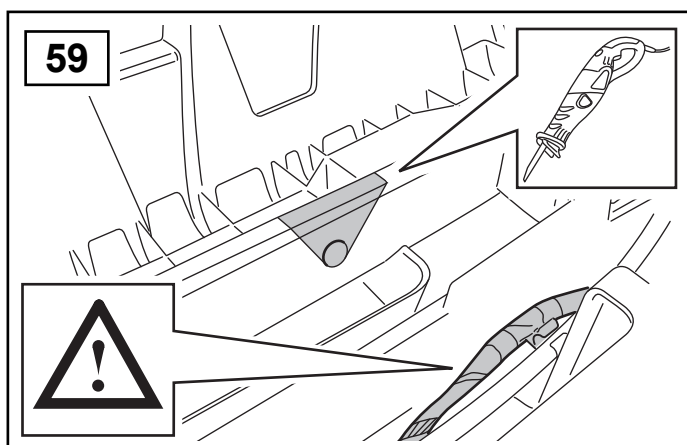
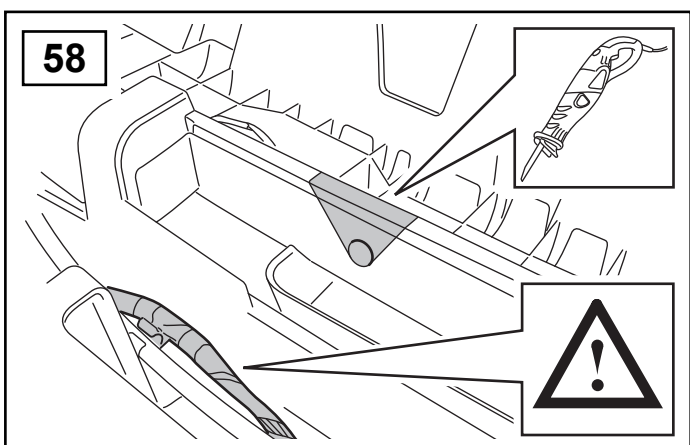
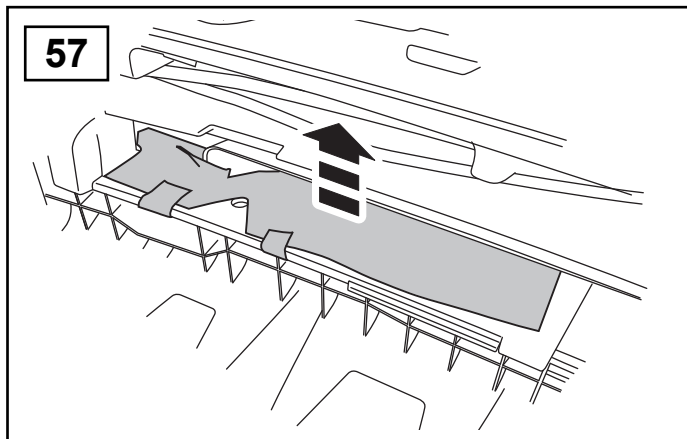
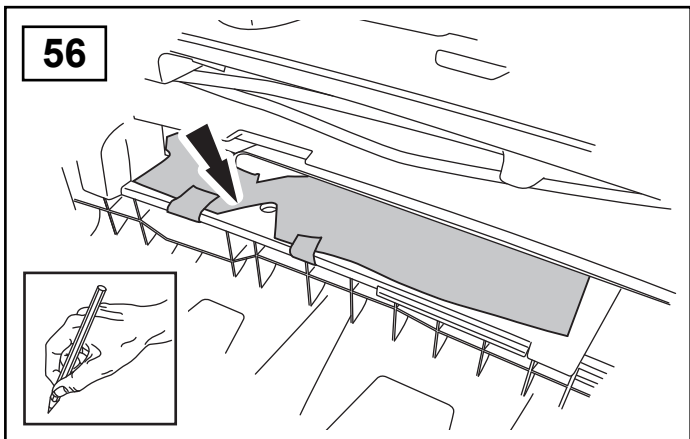

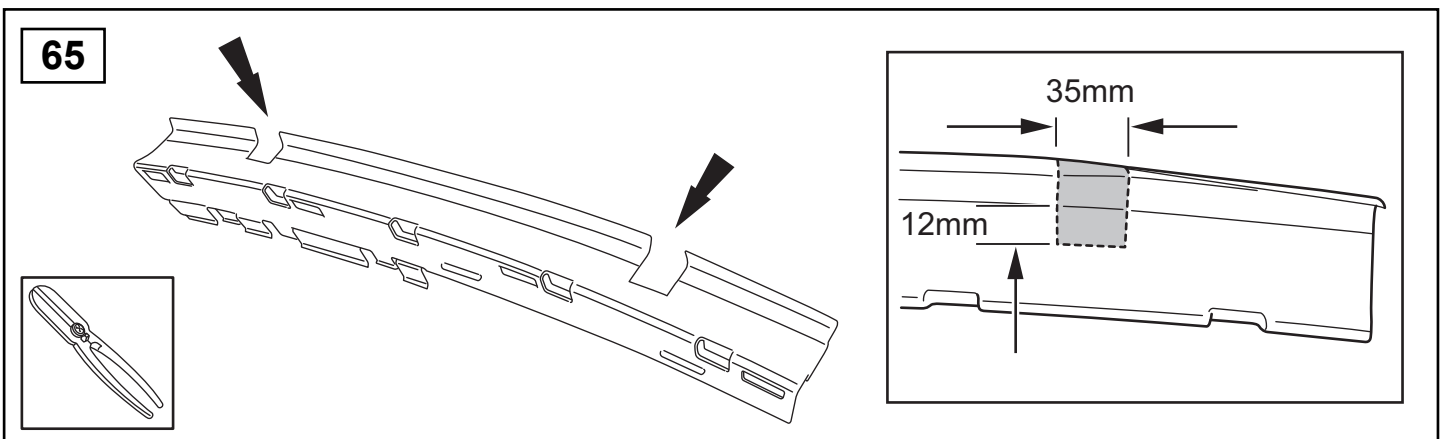
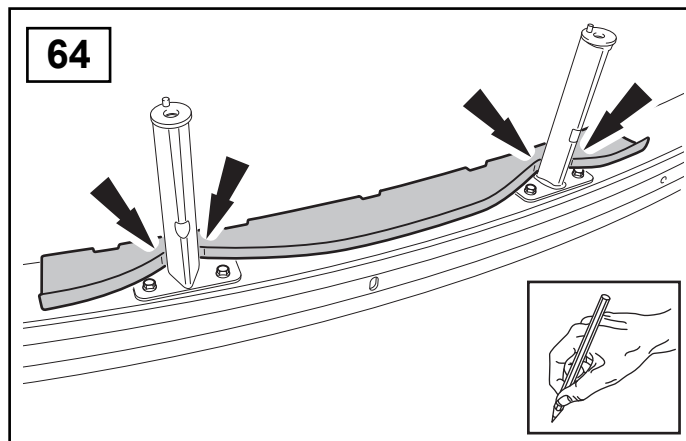
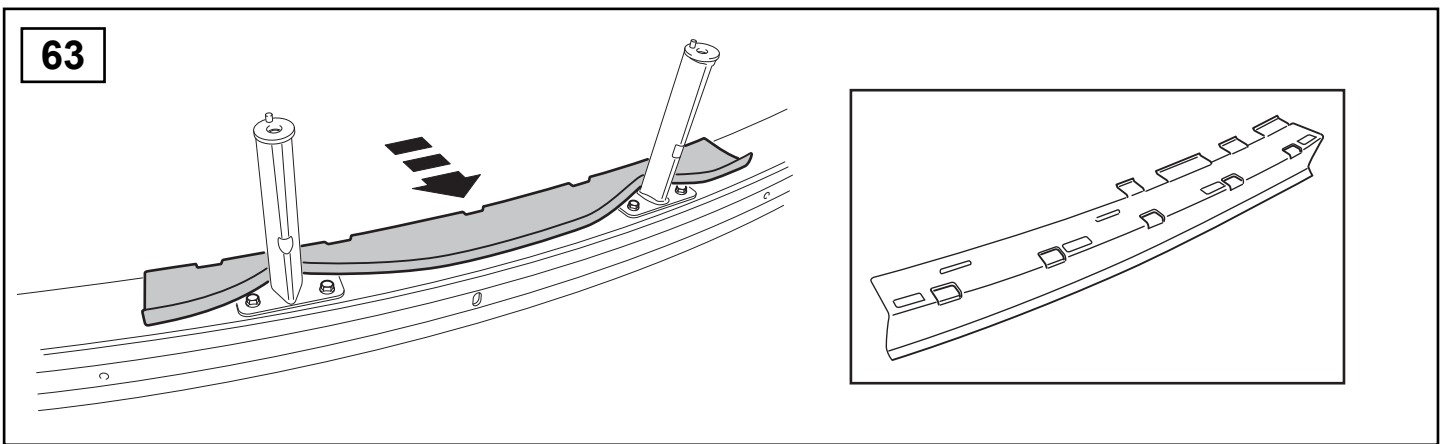
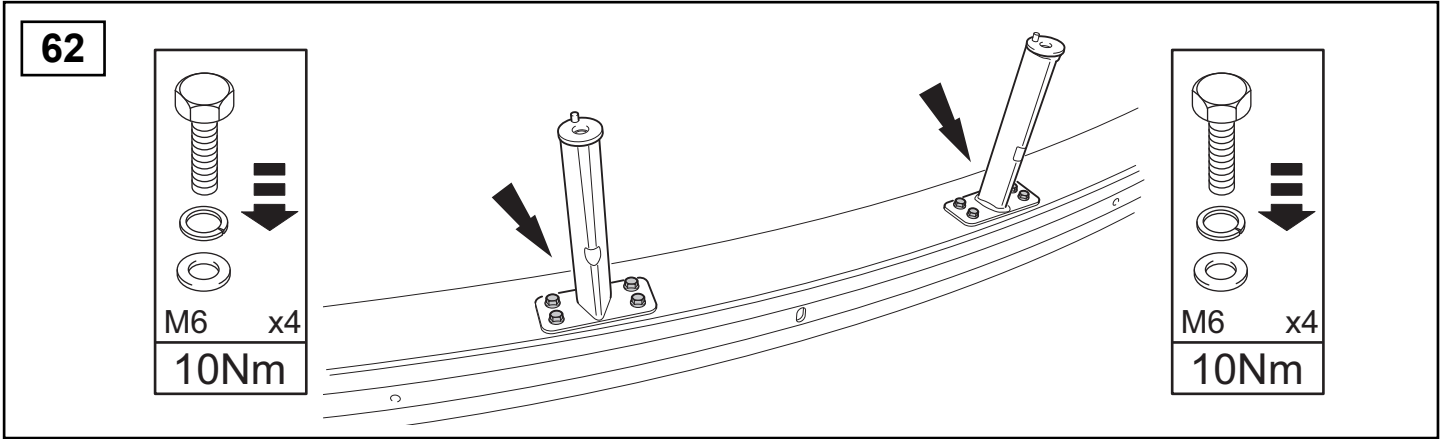

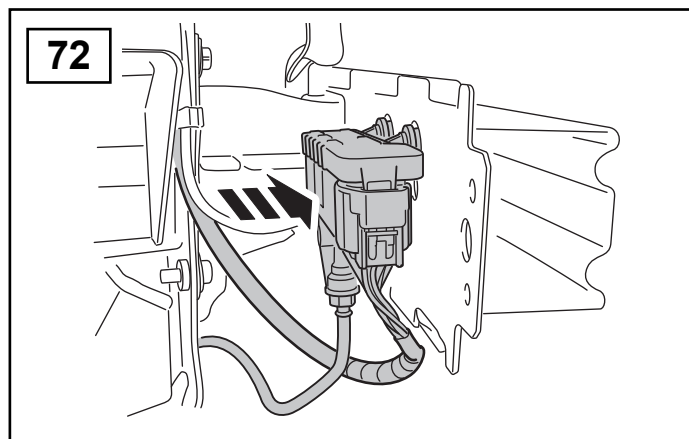
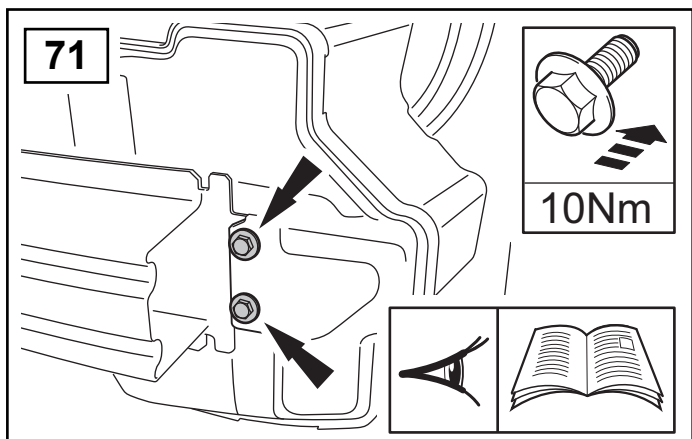
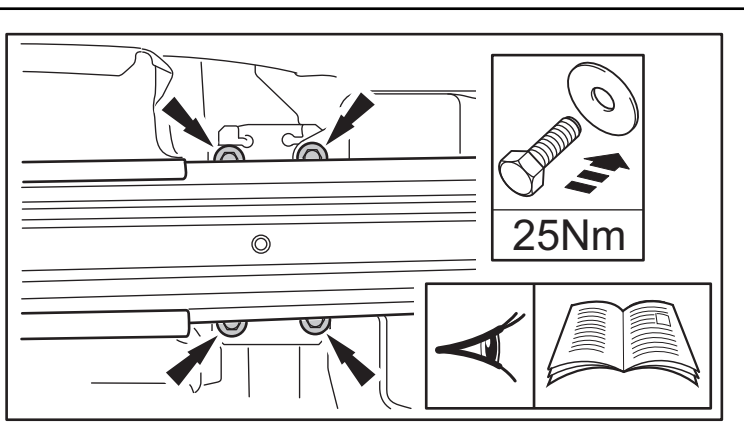
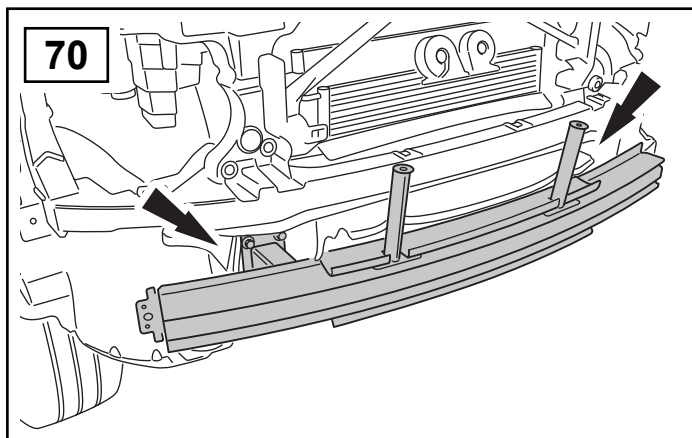
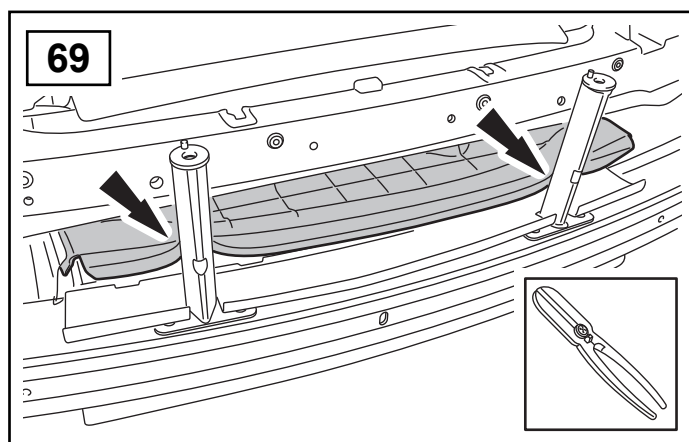
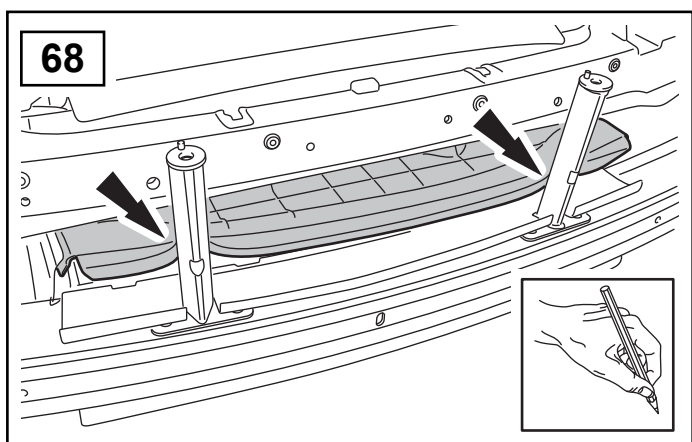
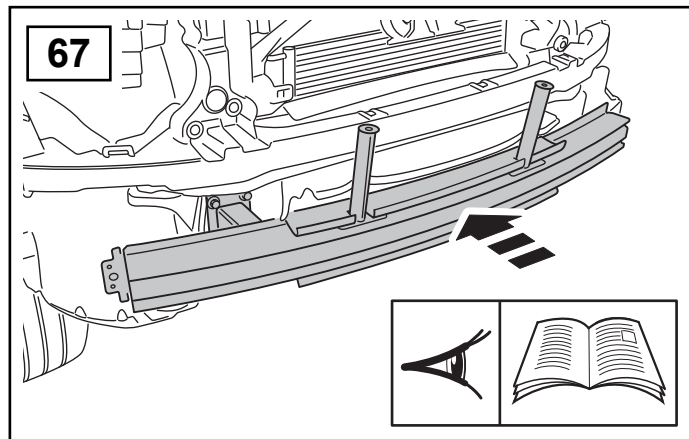
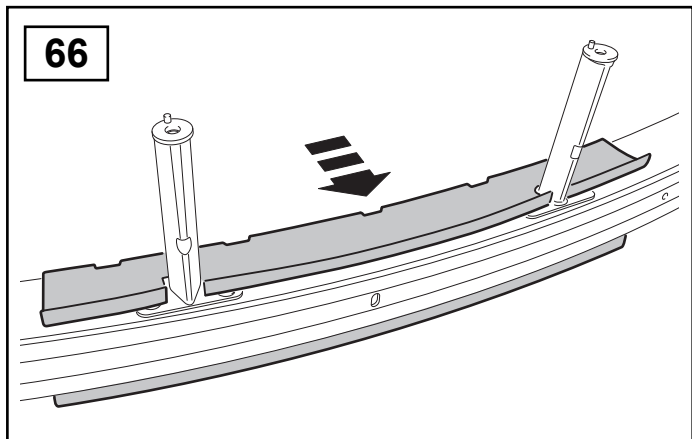

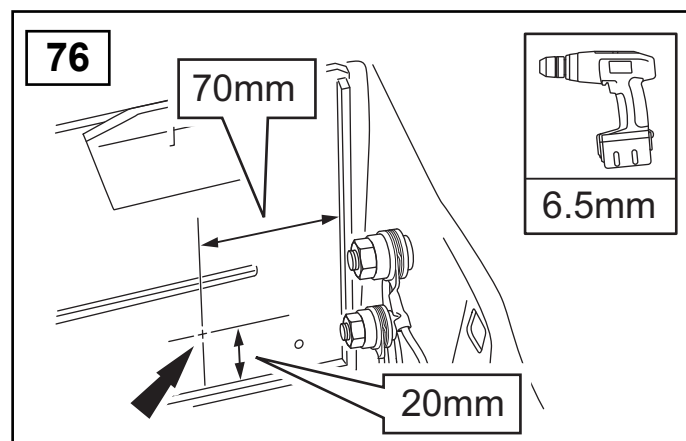
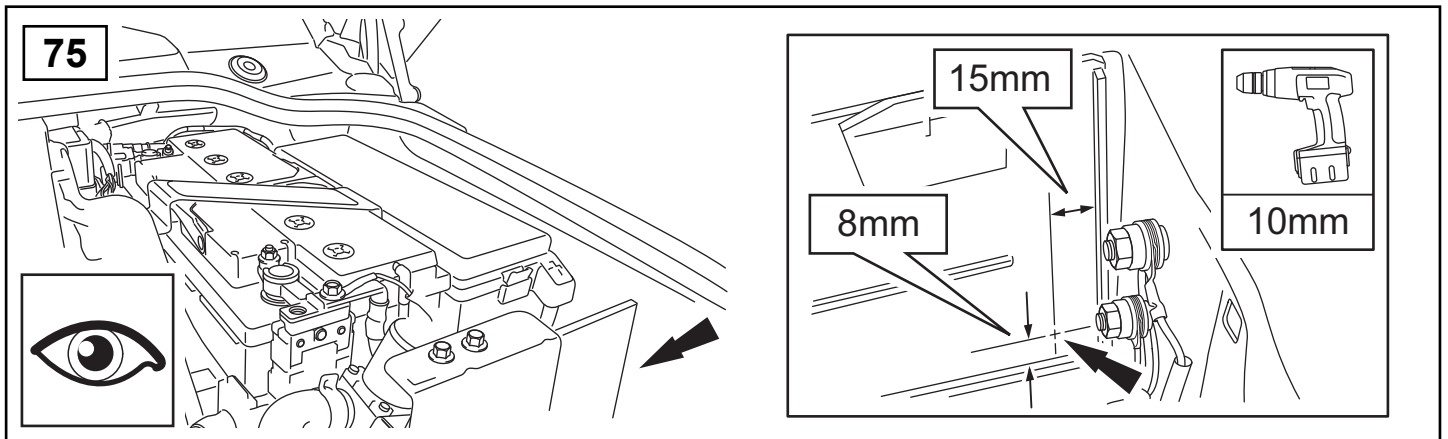
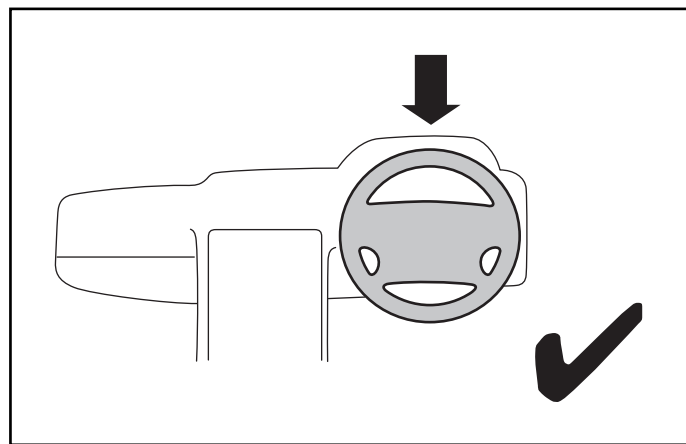
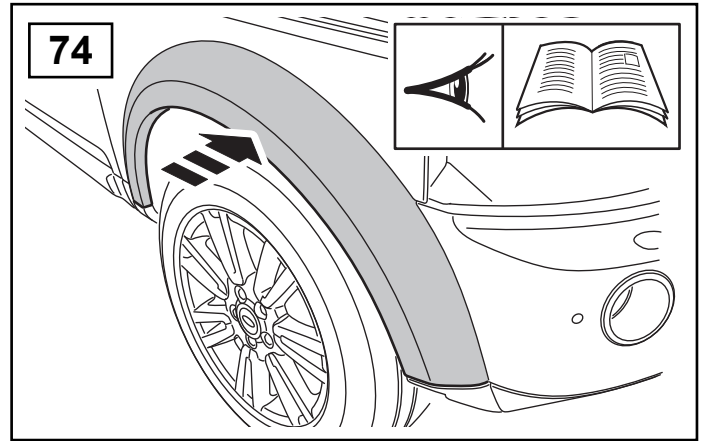
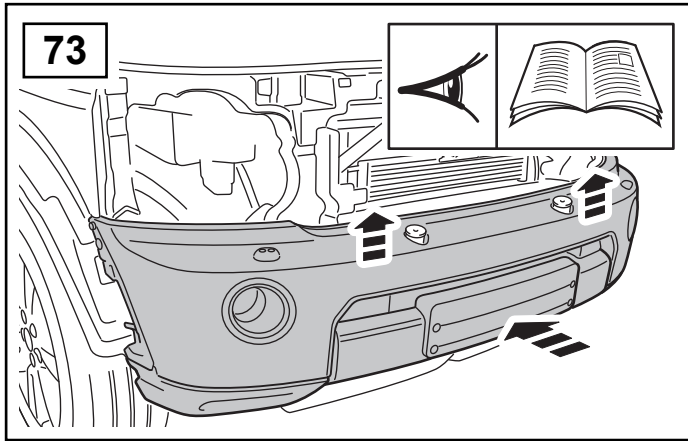

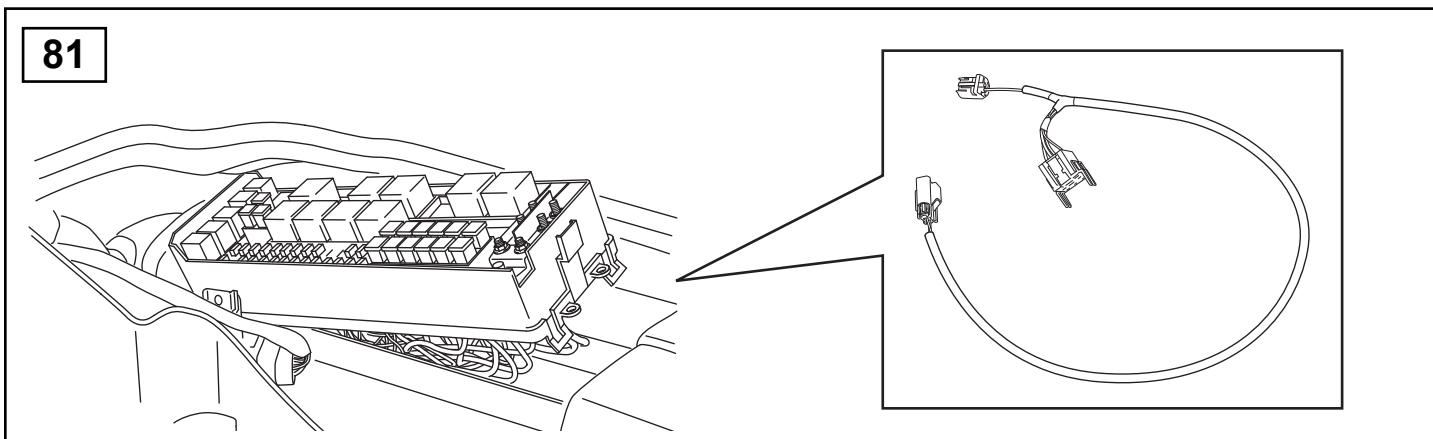
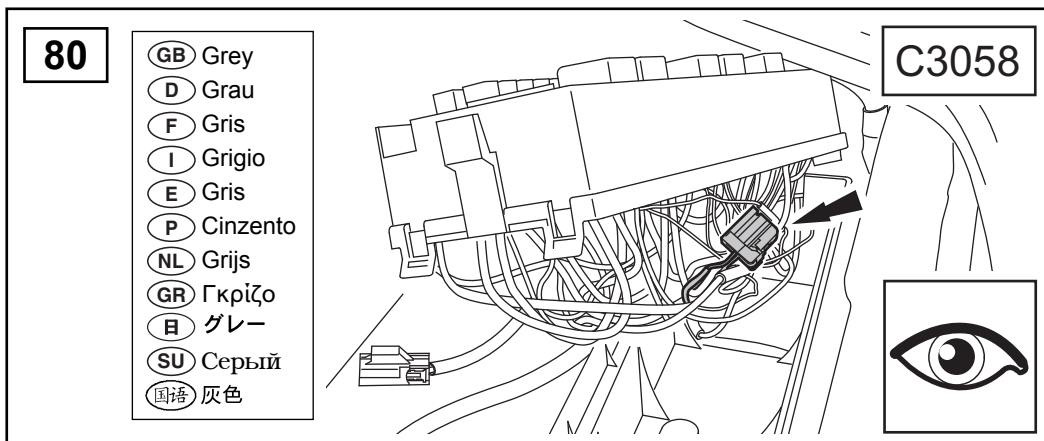
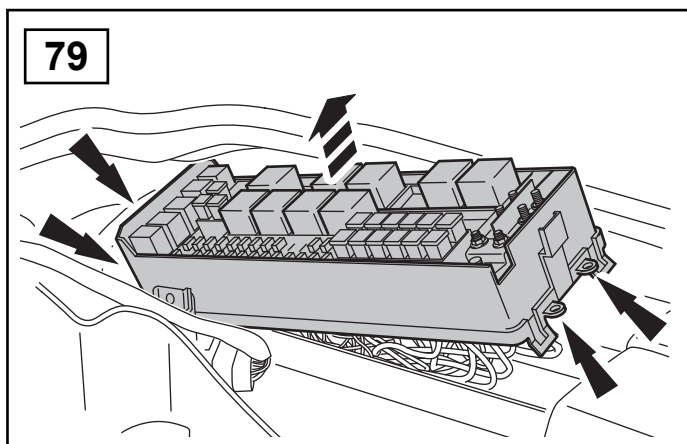
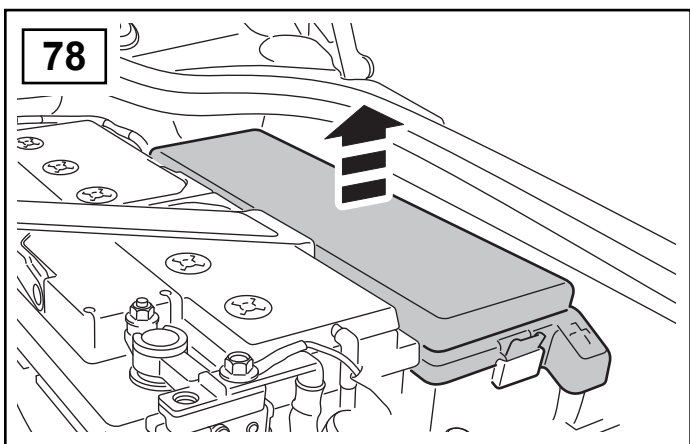
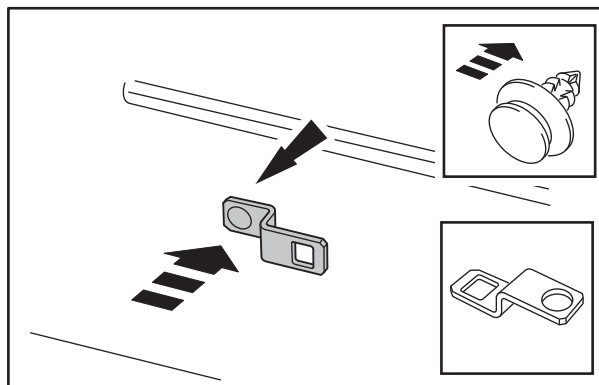
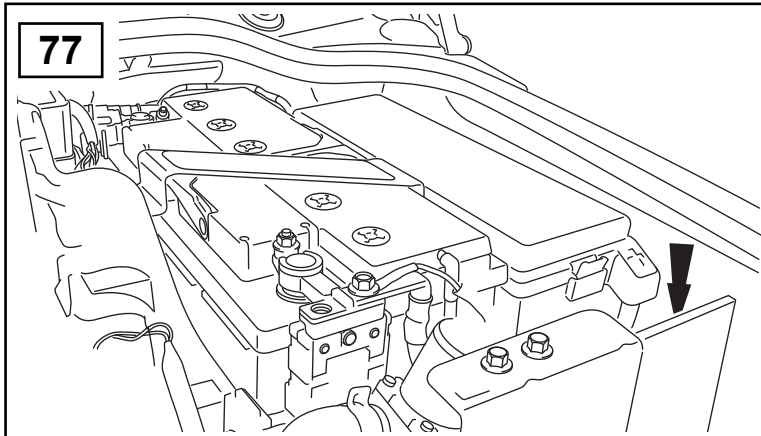

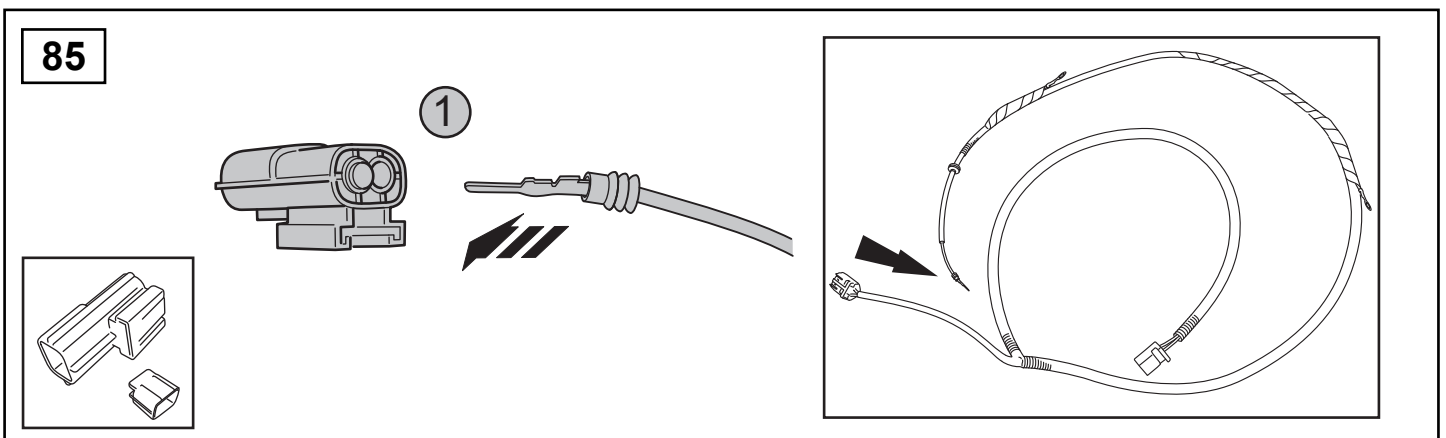
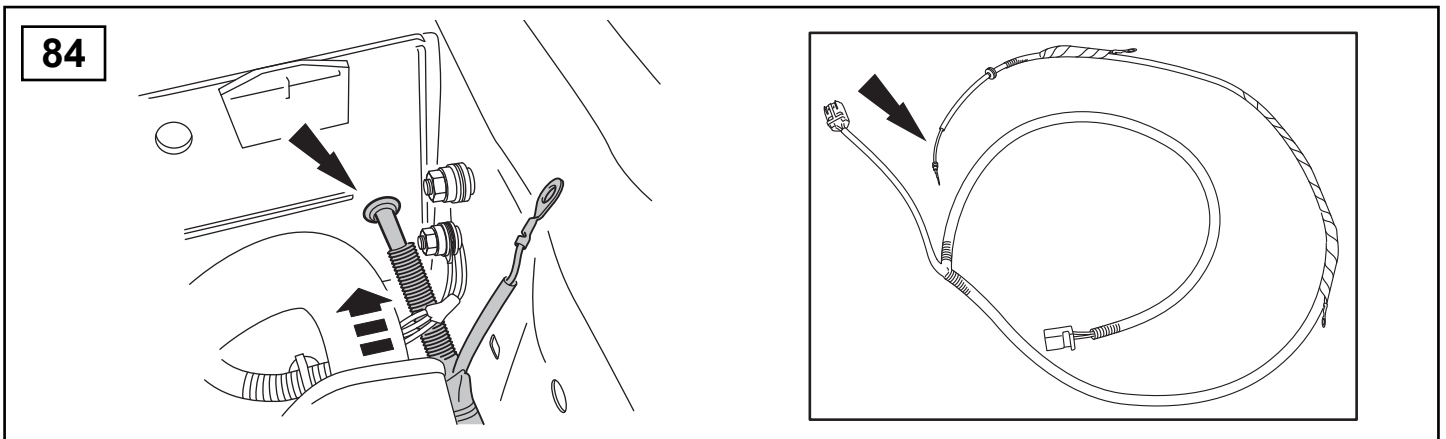
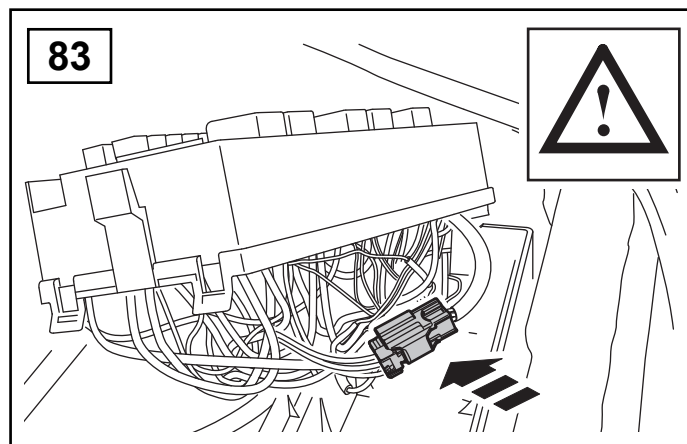
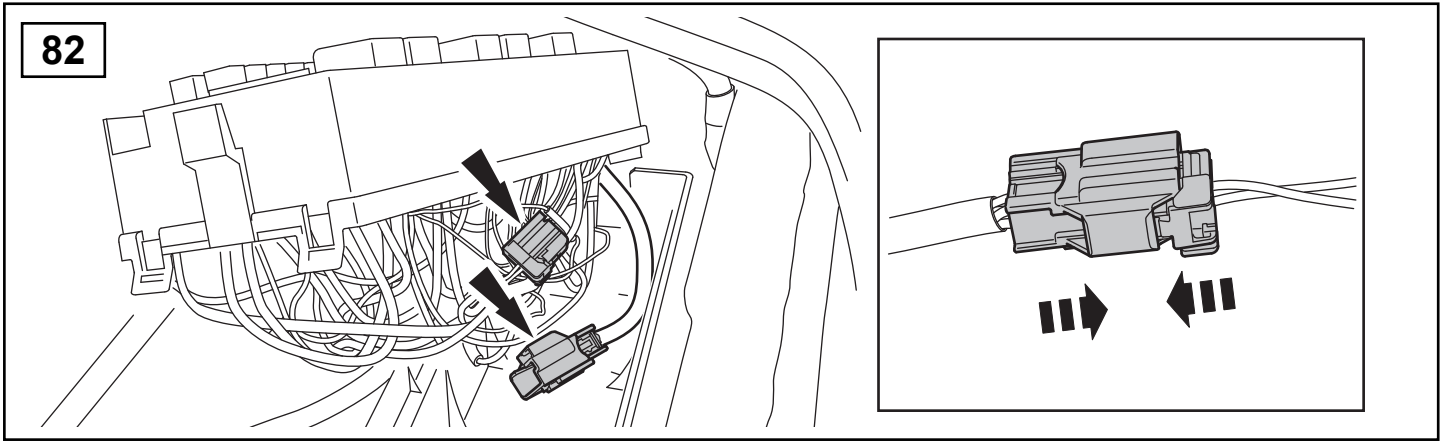

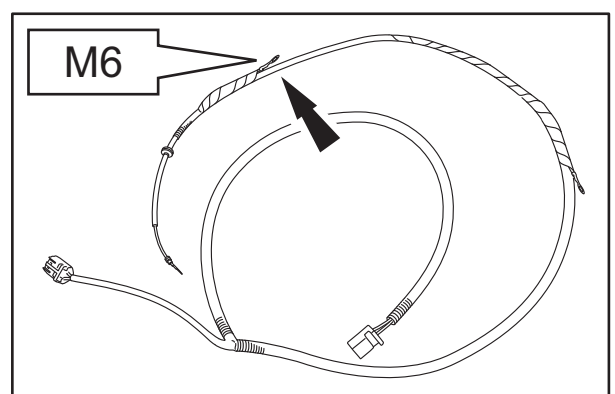
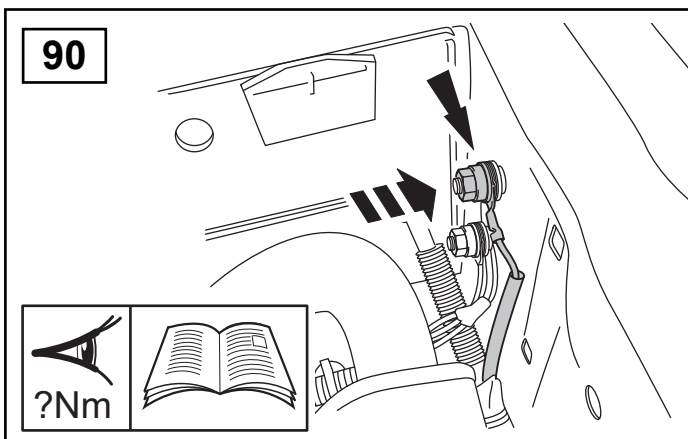
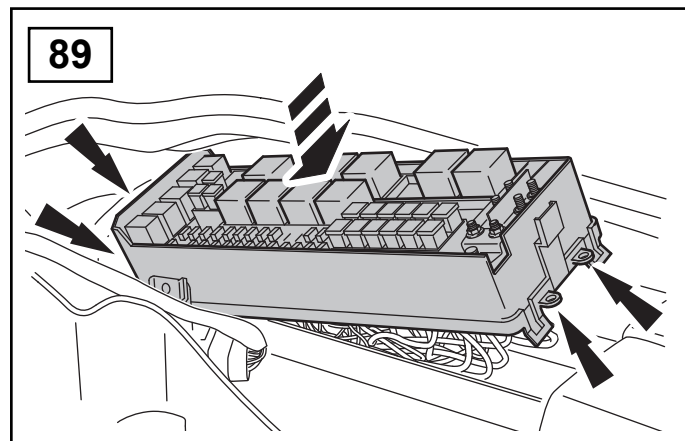
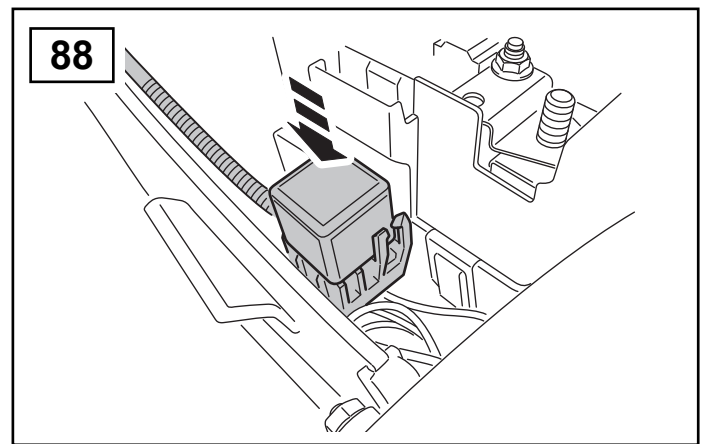
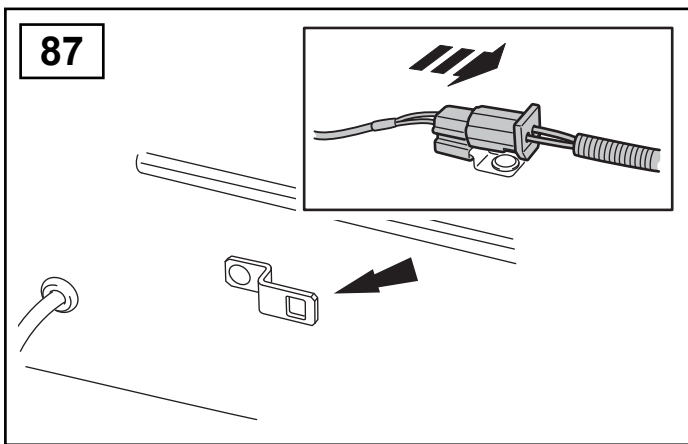
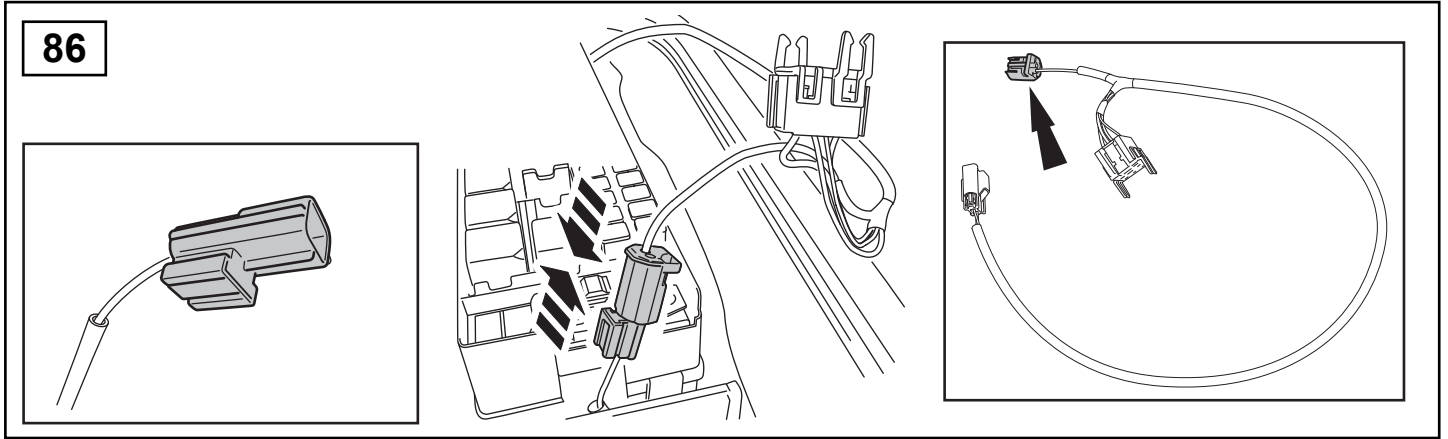

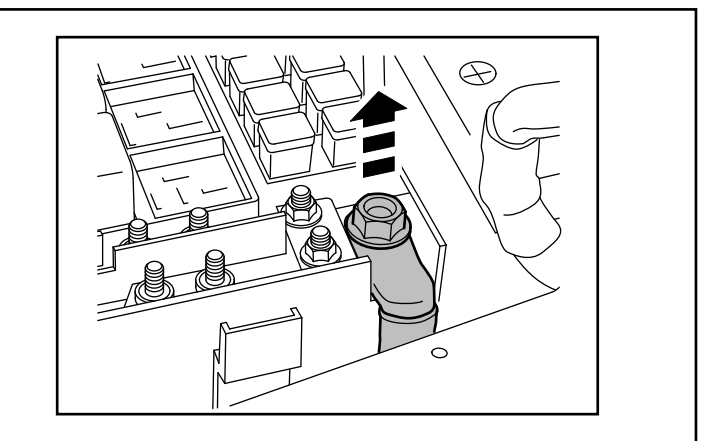
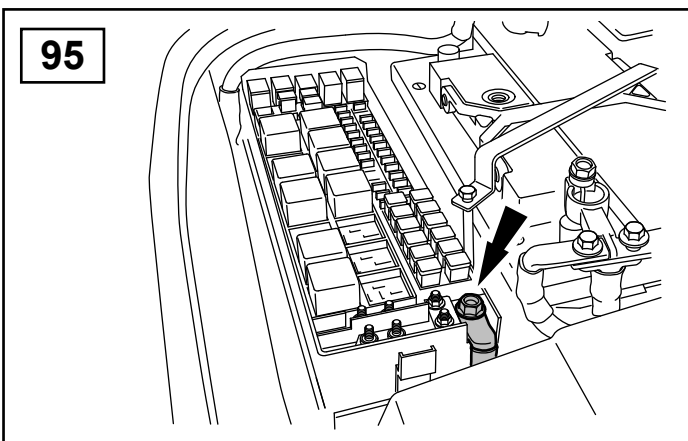
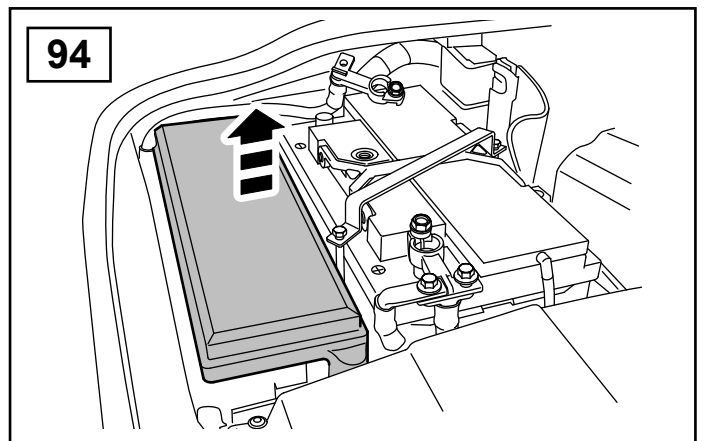
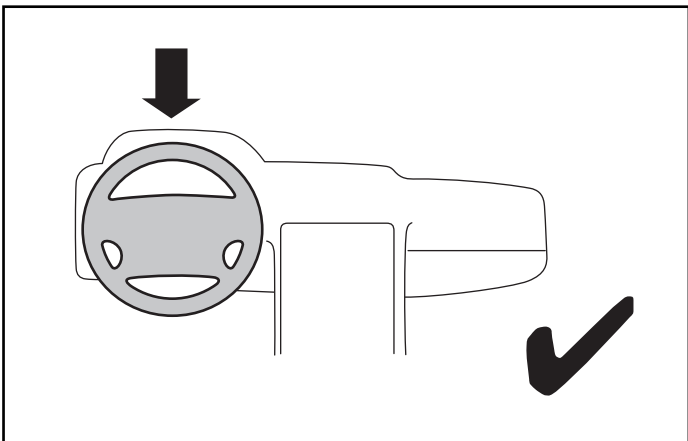
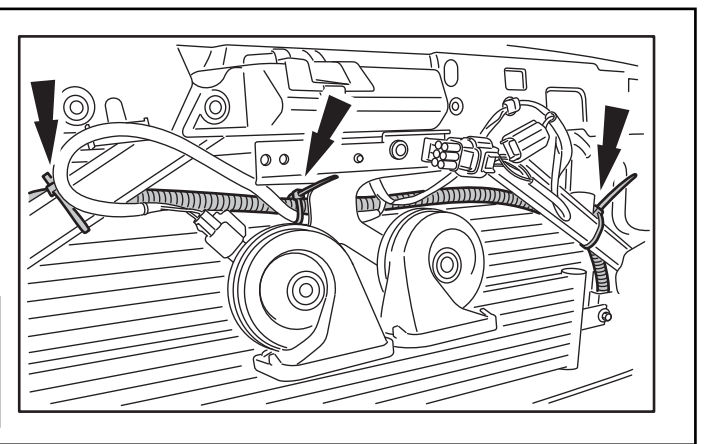
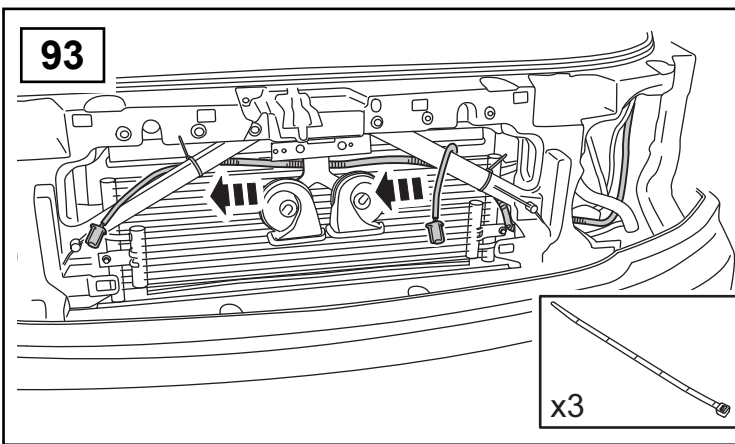
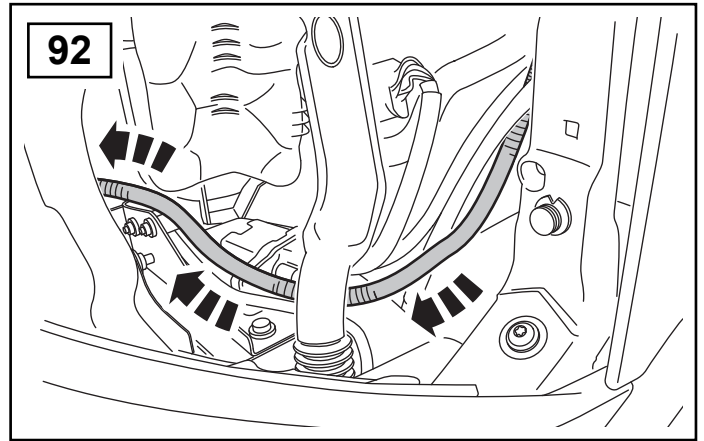
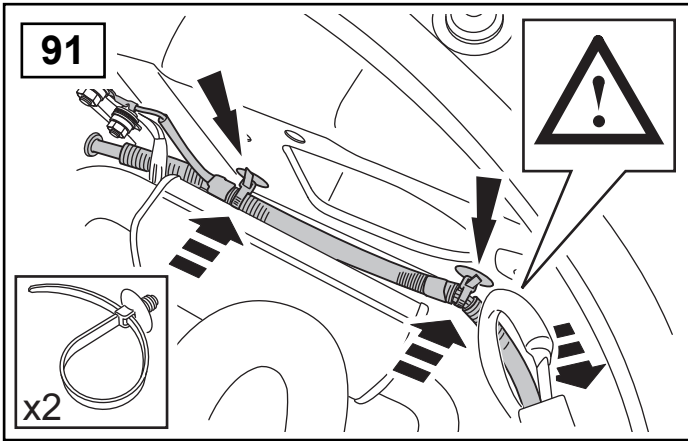

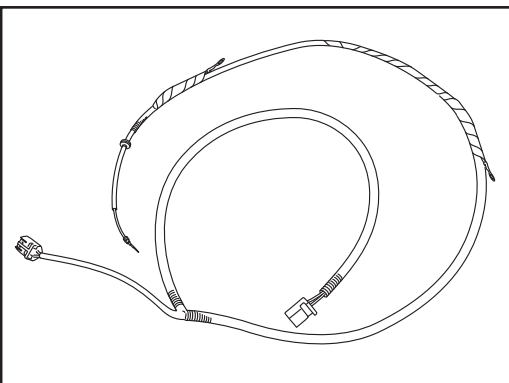
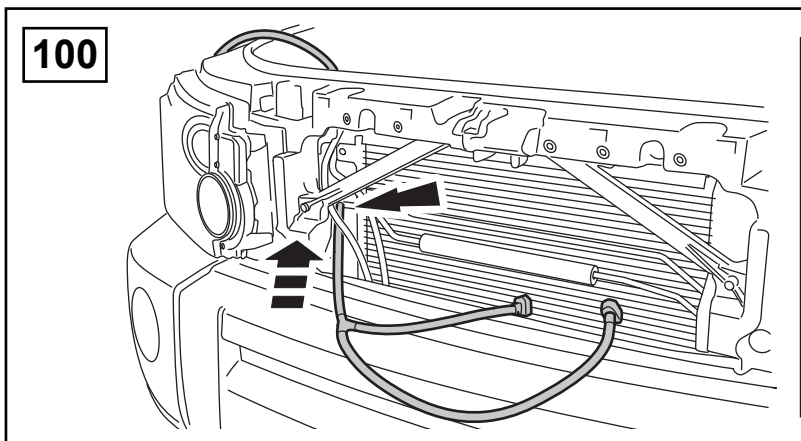
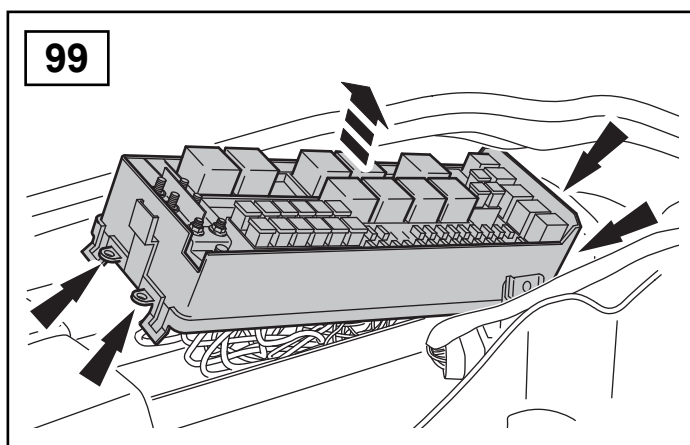
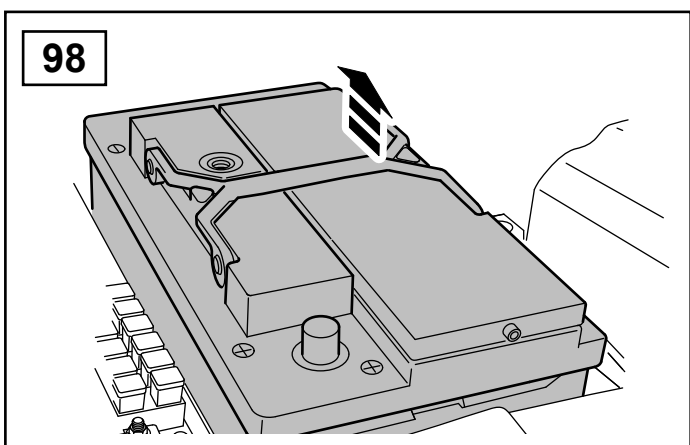
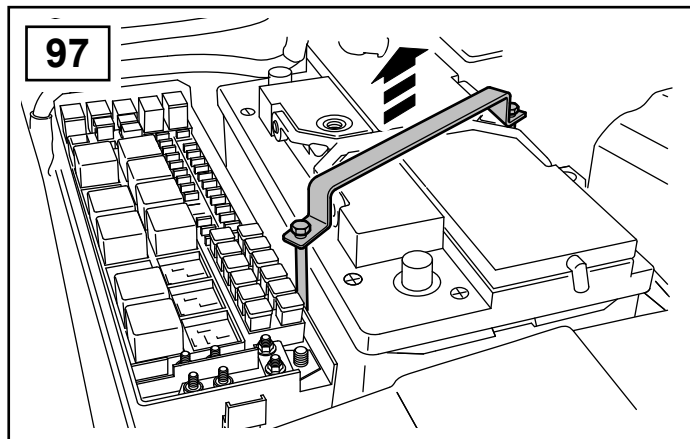
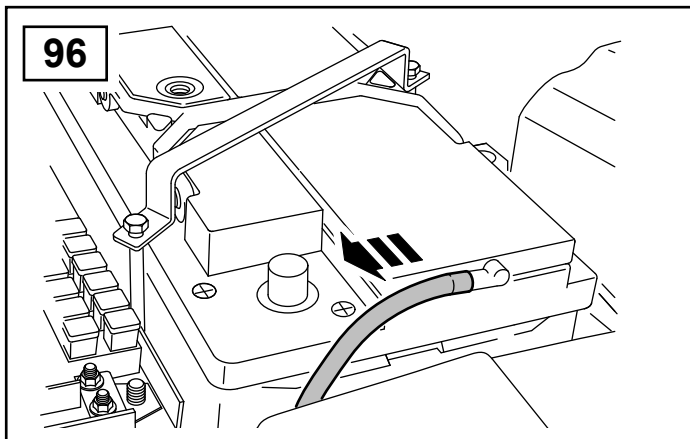

GB	Grey
D	Grau
F	Gris
I	Grigio
E	Gris
P	Cinzento
NL	Grijs
GR	Γκριζο
日	グレー
SU	Серый
国	灰色

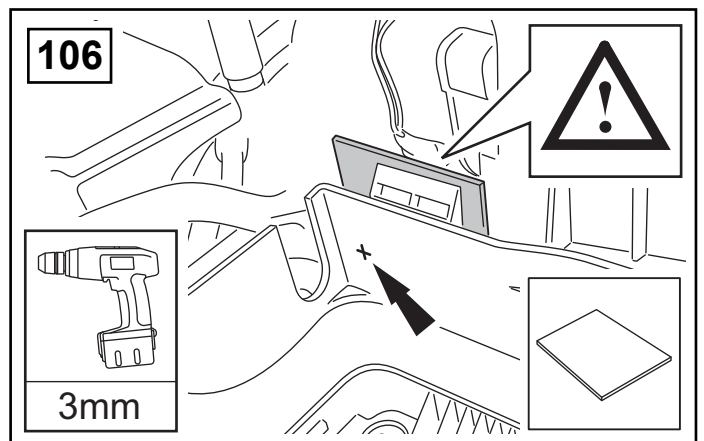
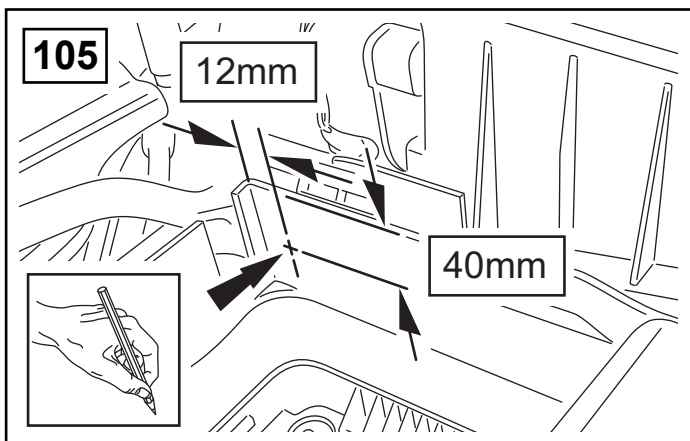
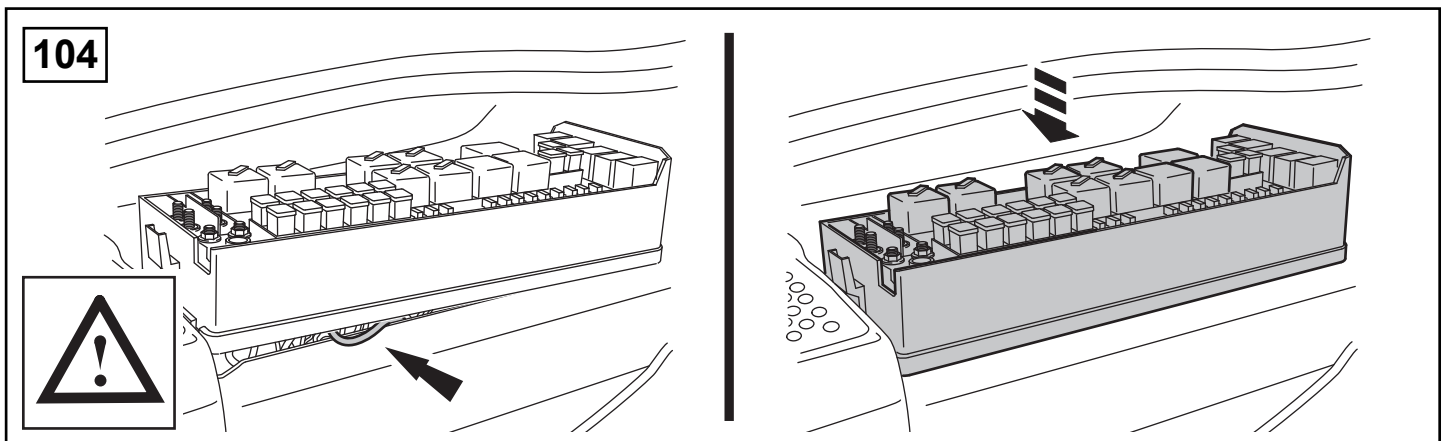
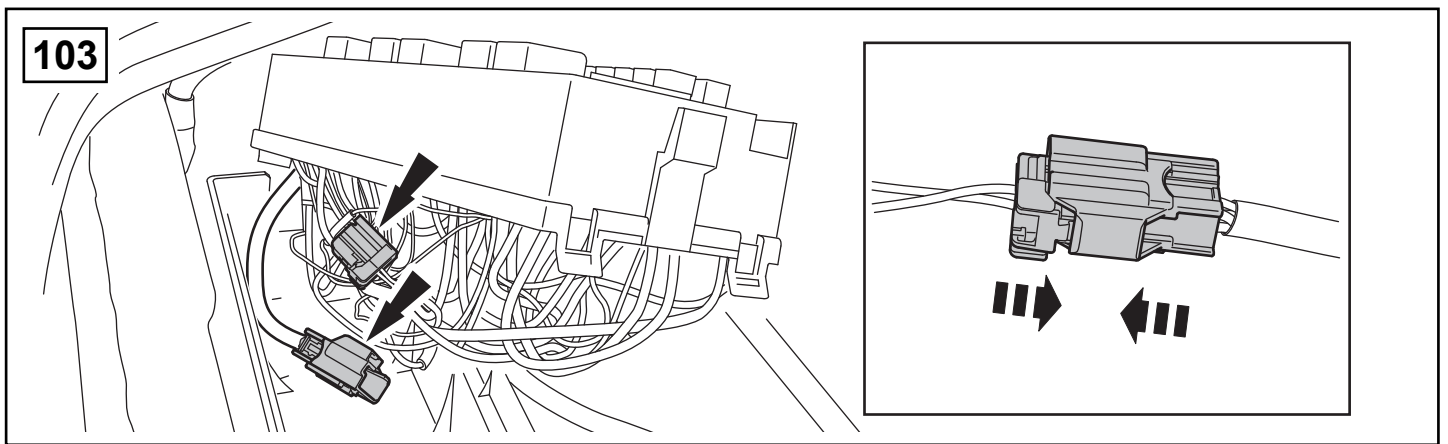
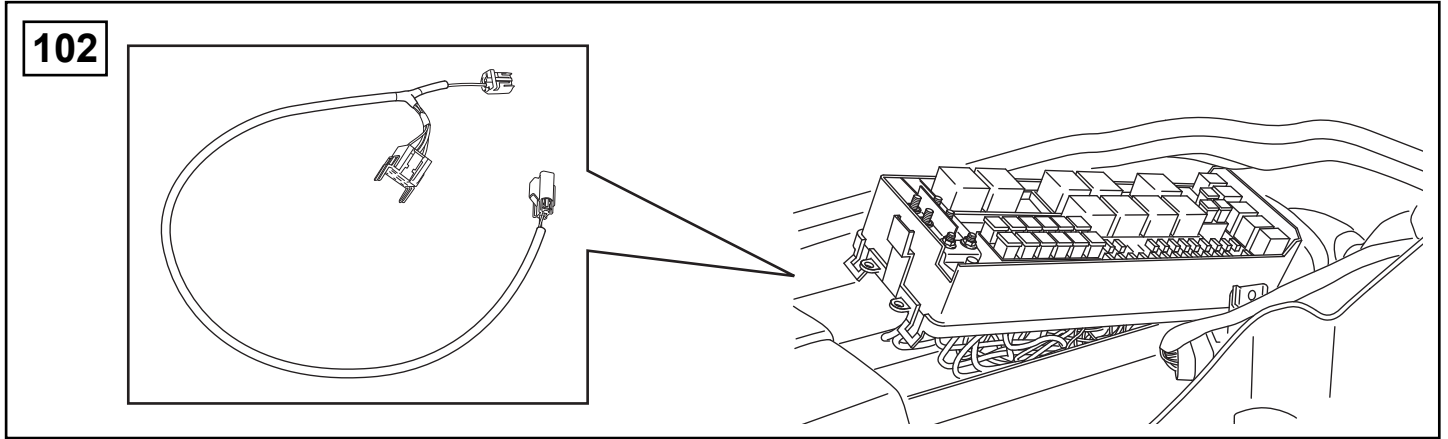

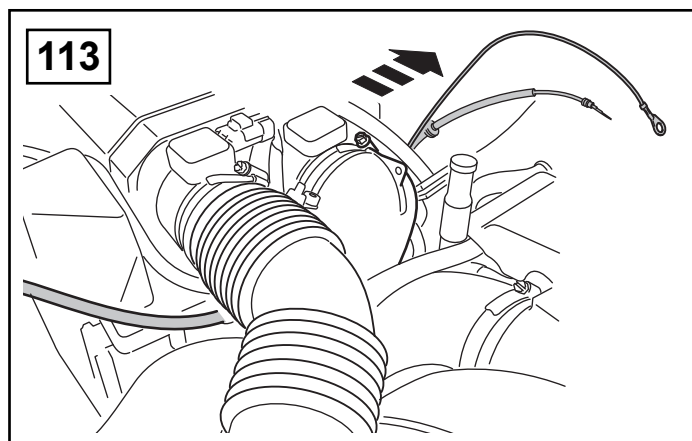
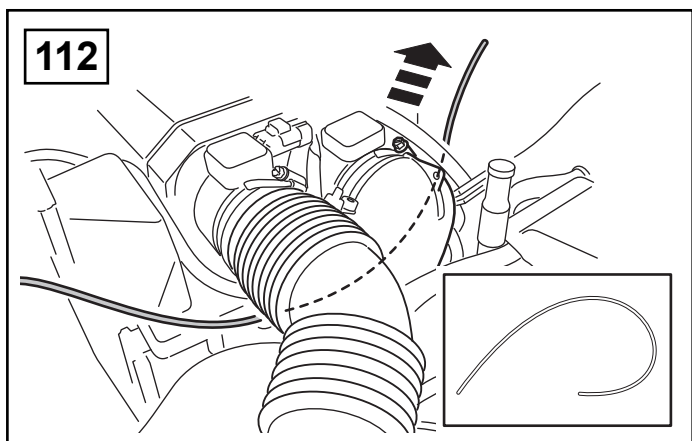
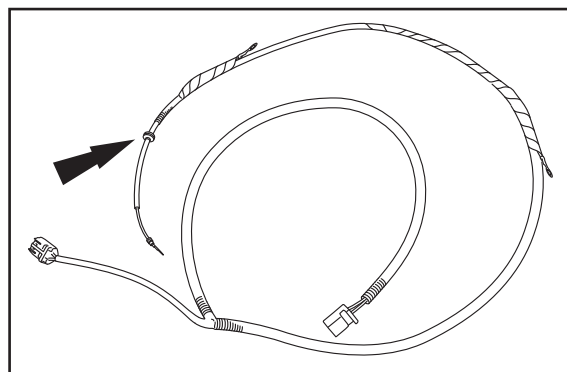
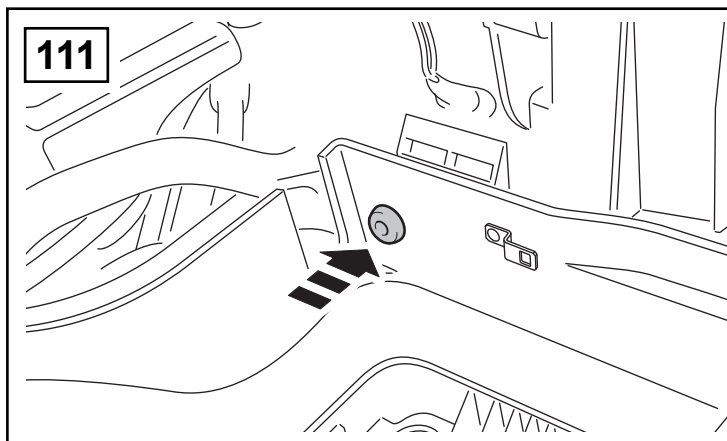
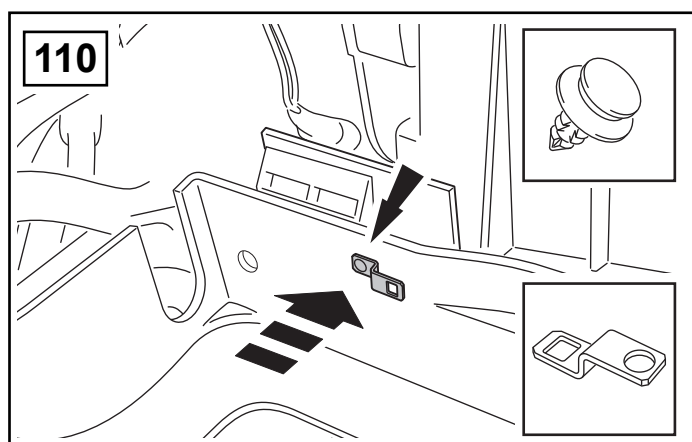
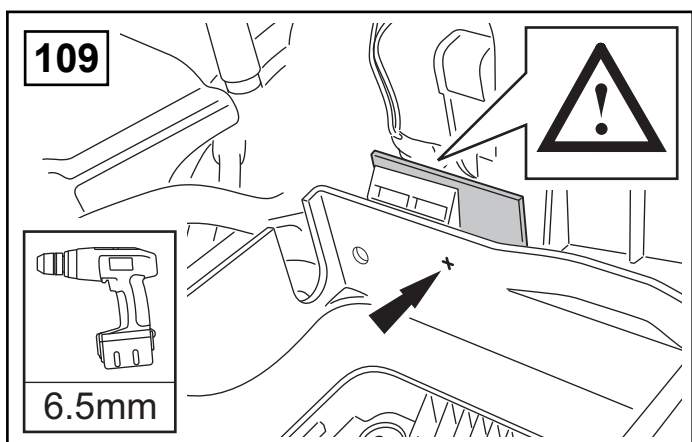
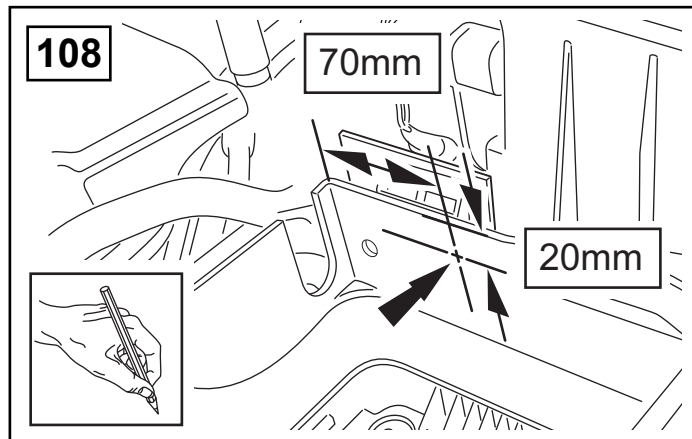
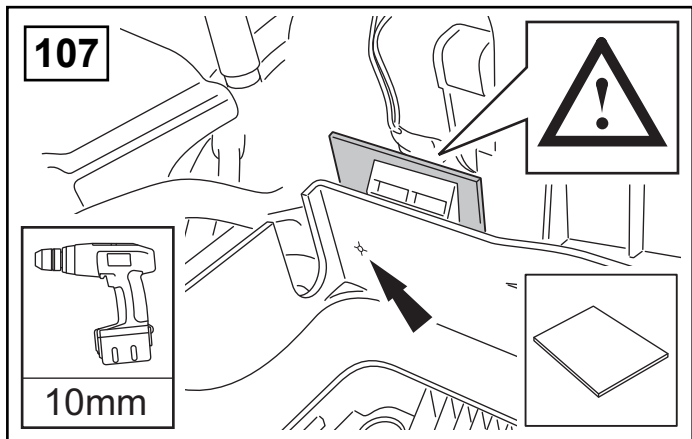

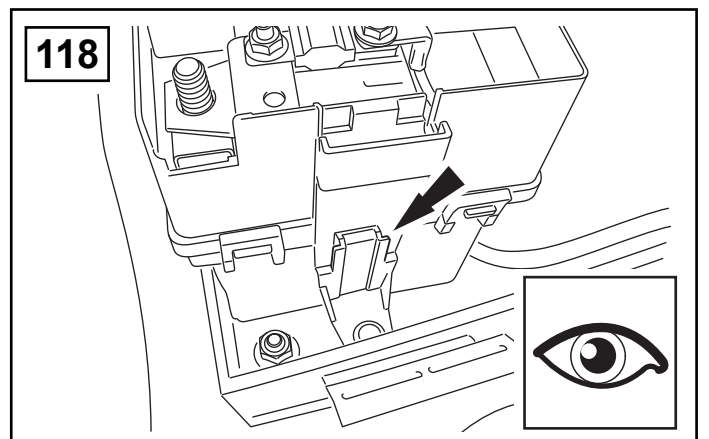
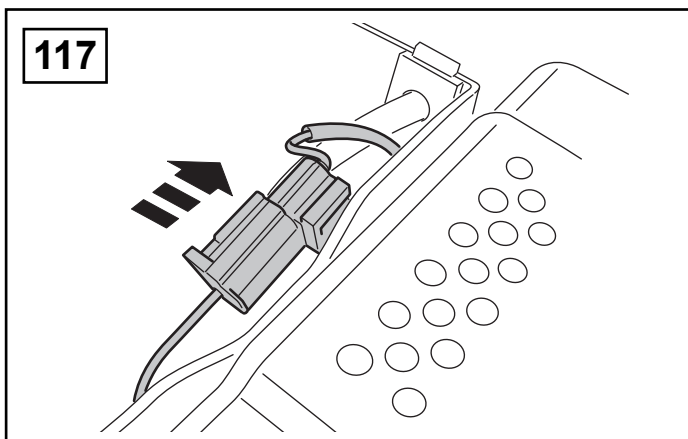
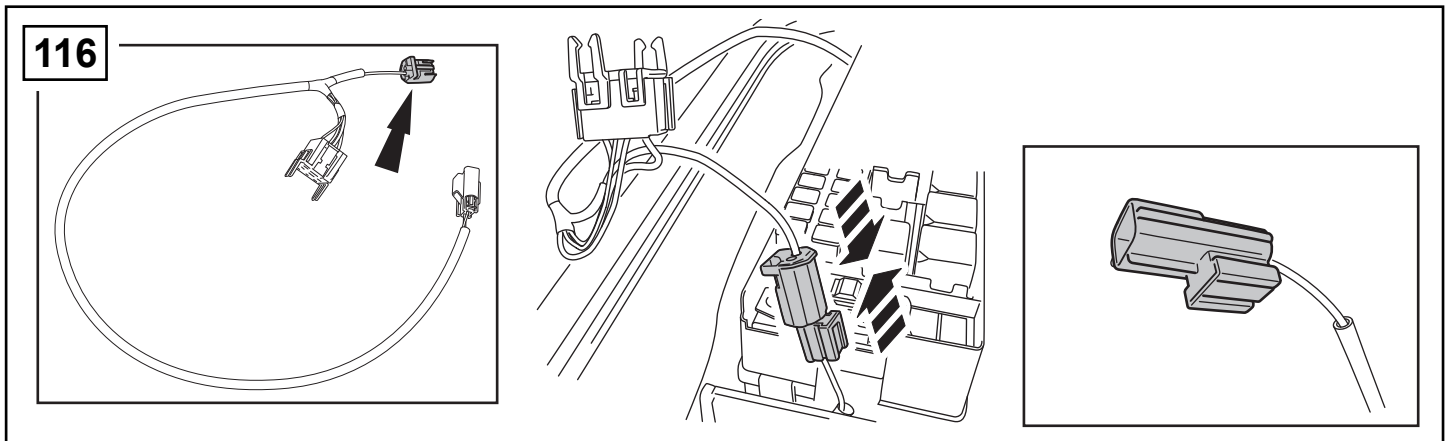
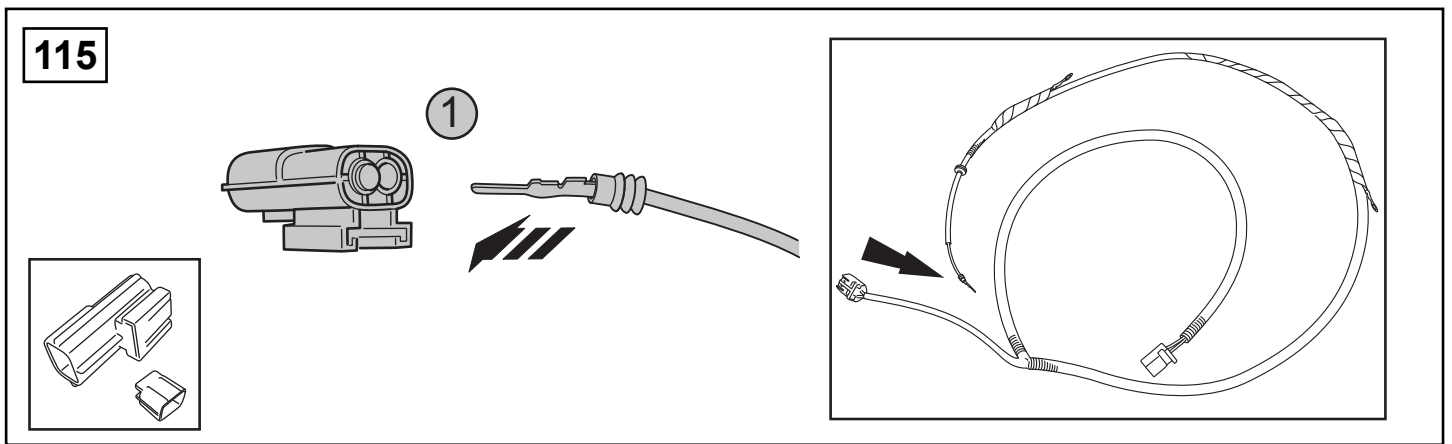
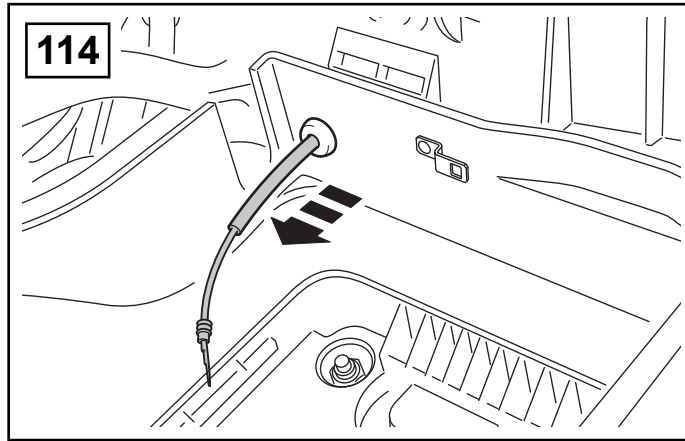

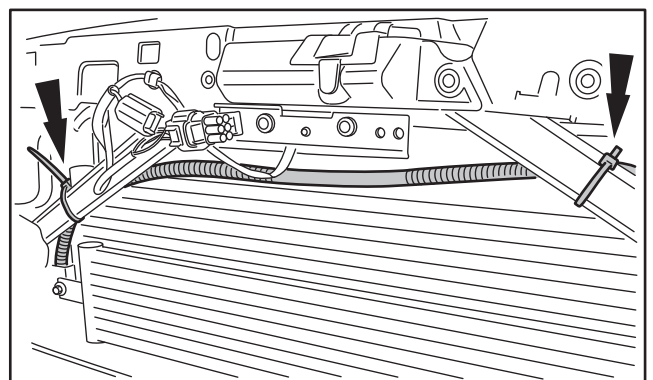
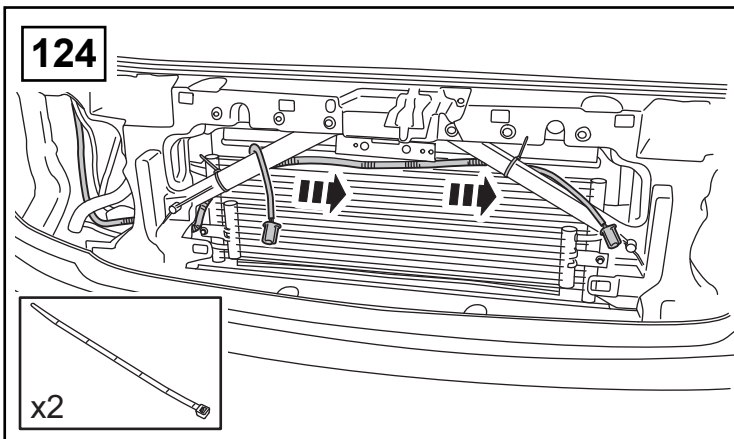
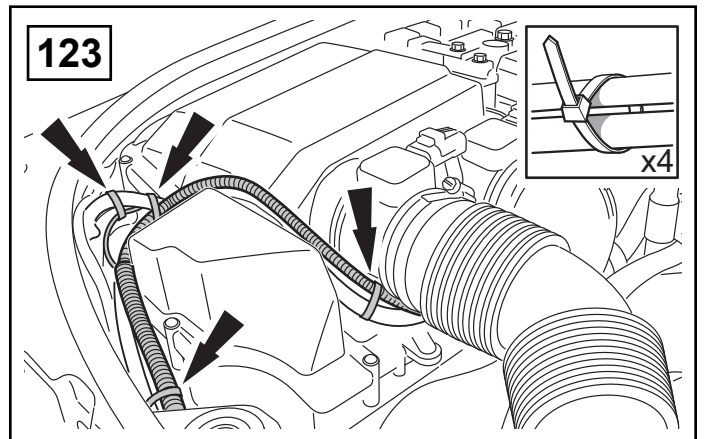
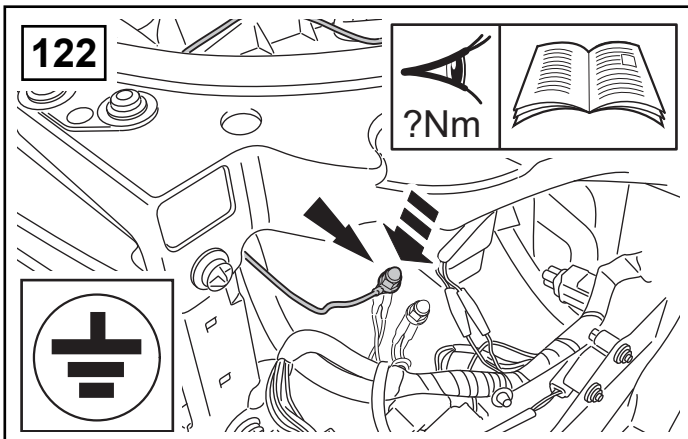
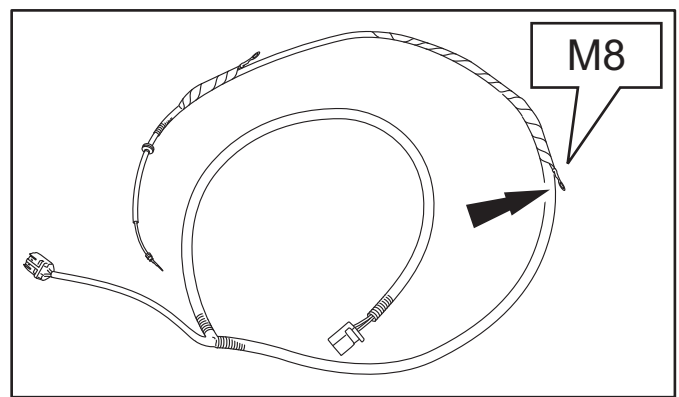
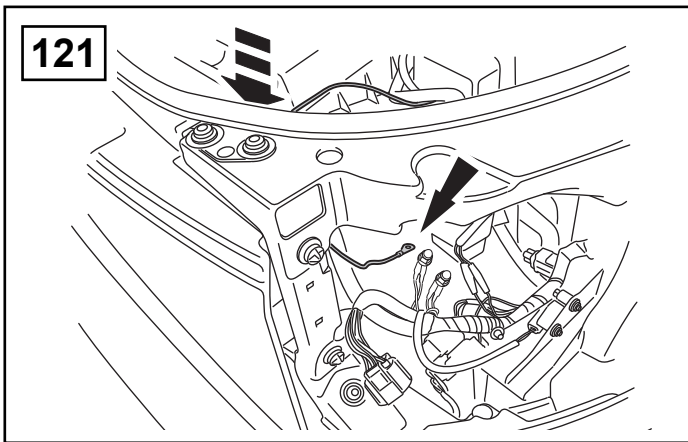
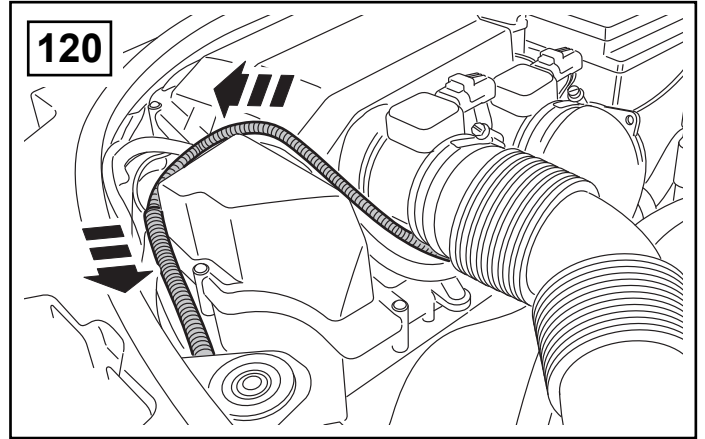
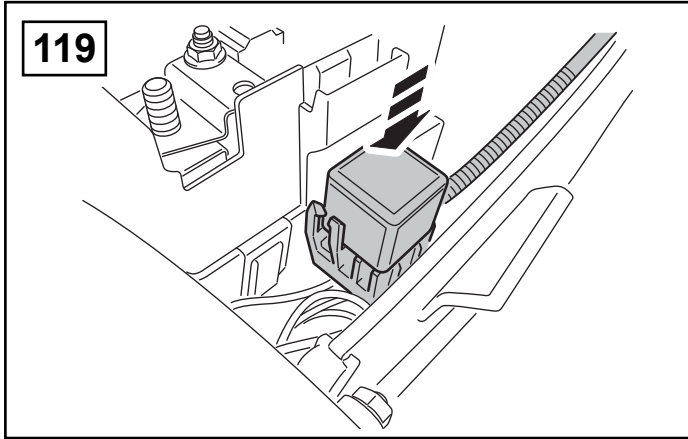

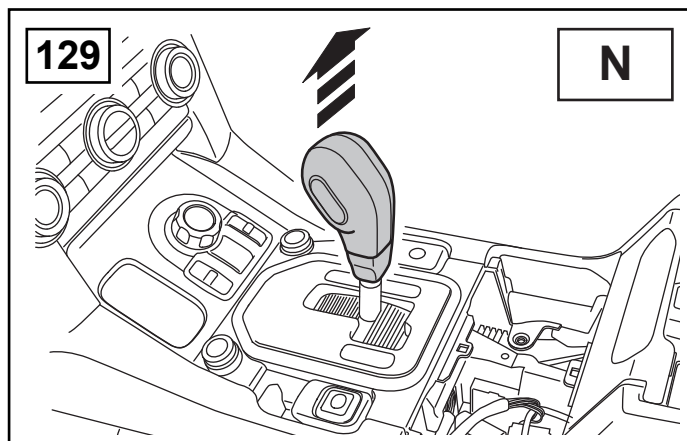
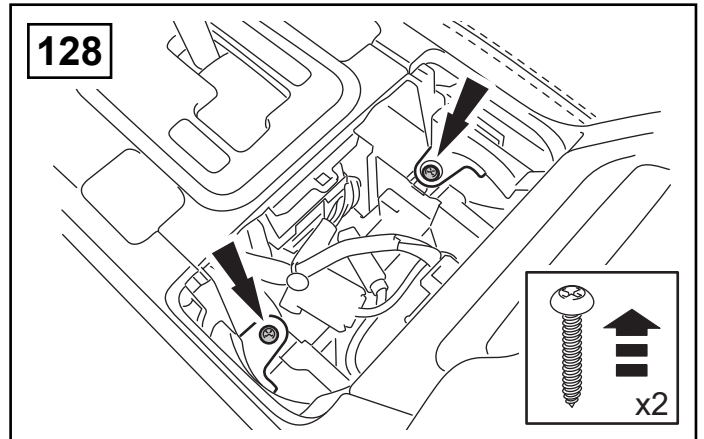
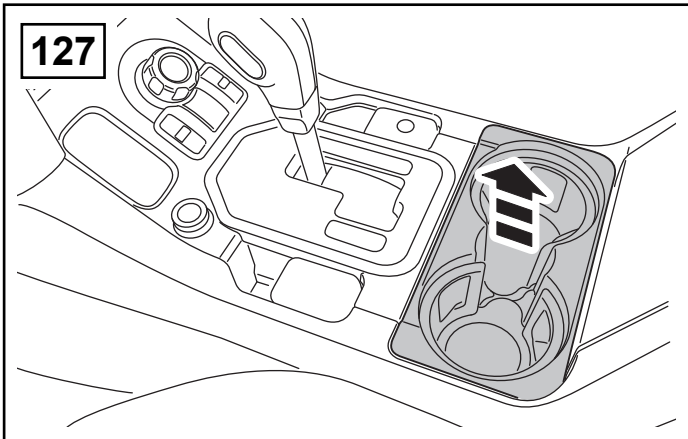
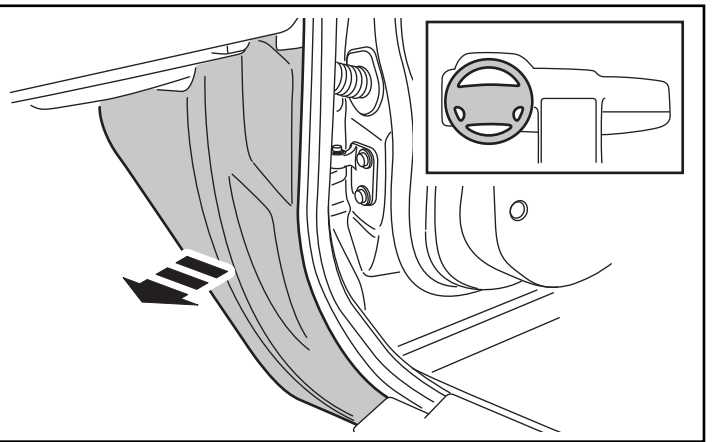
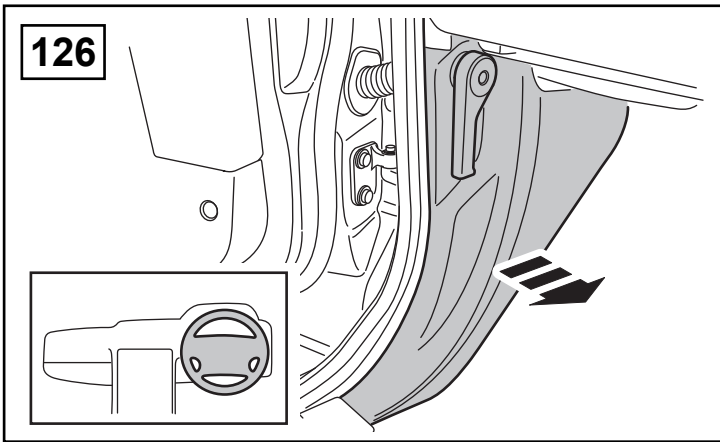
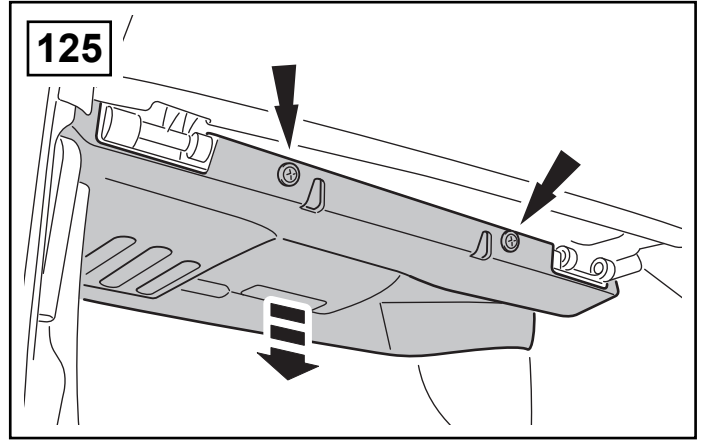
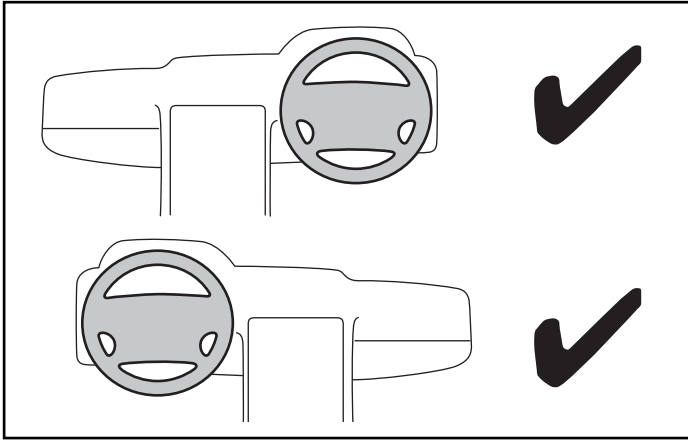

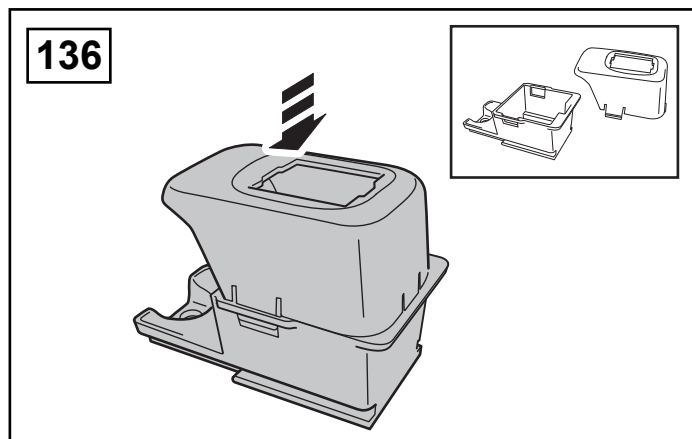
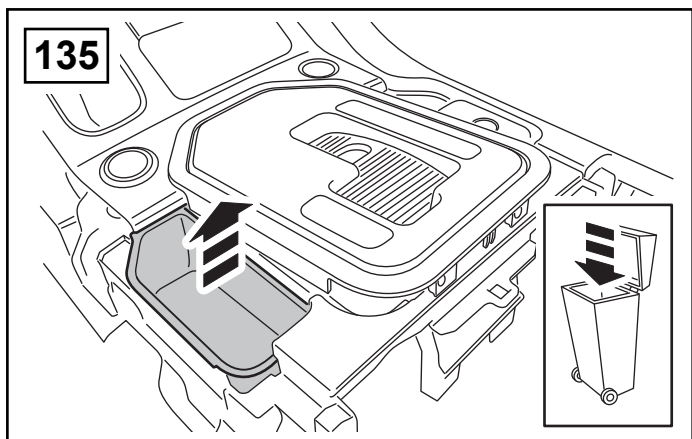
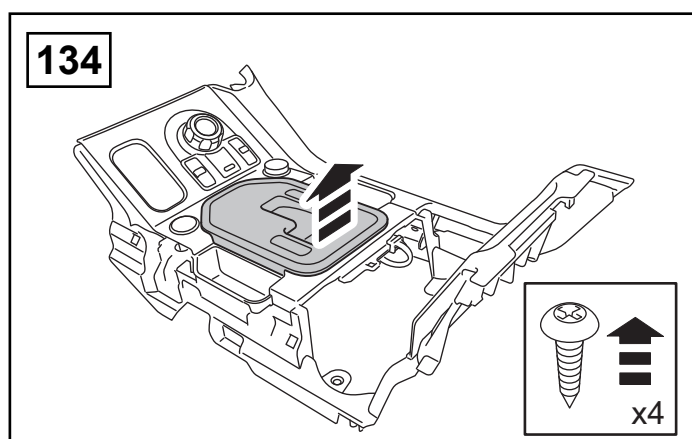
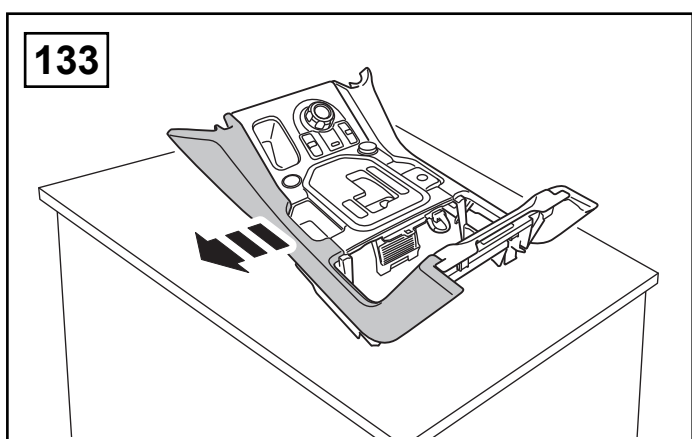
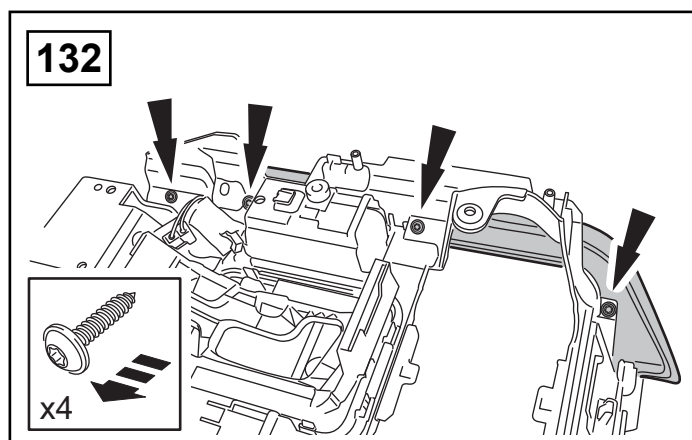
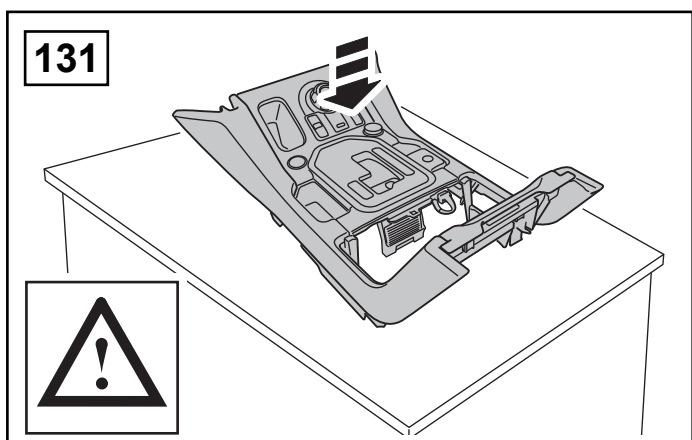
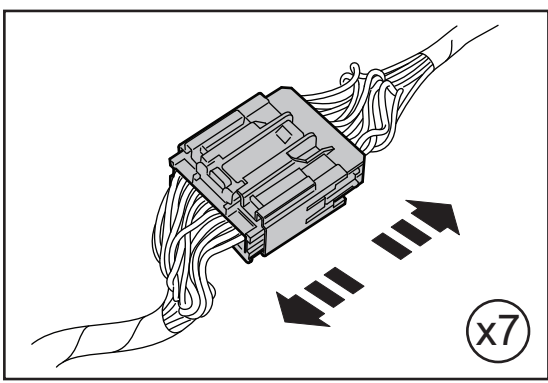
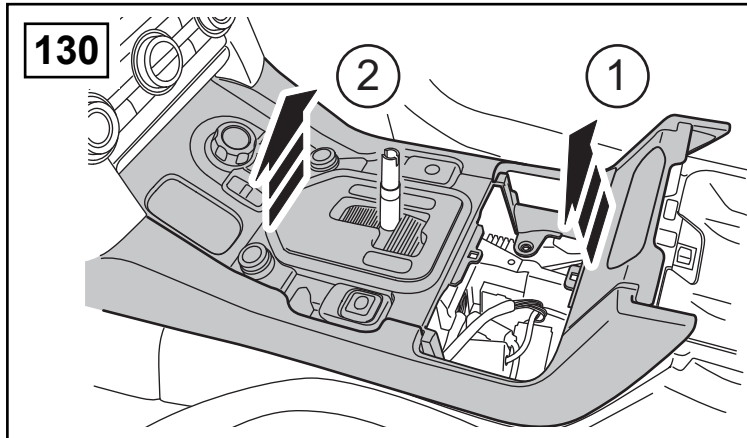

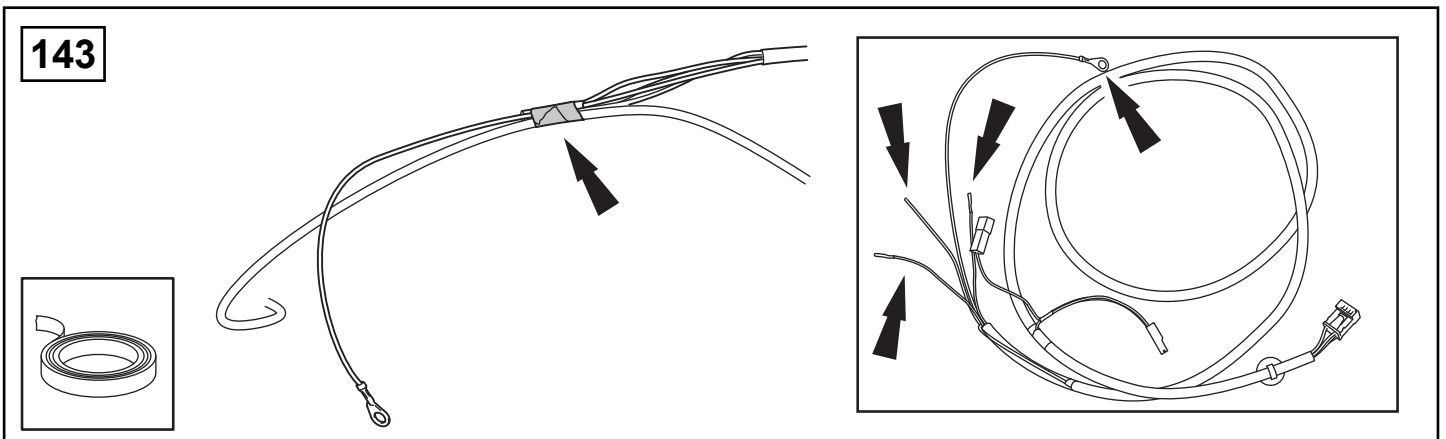
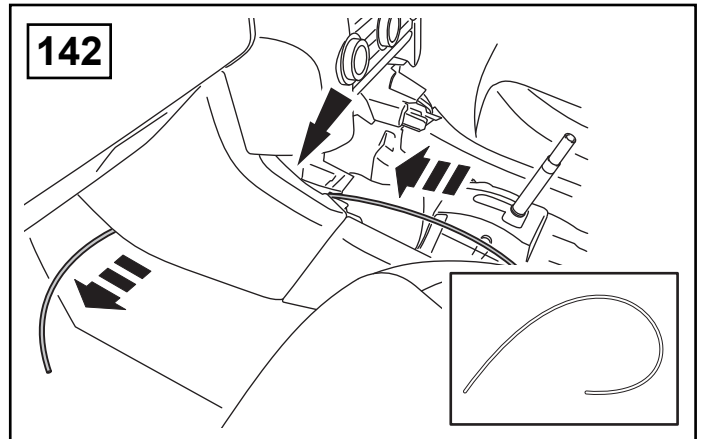
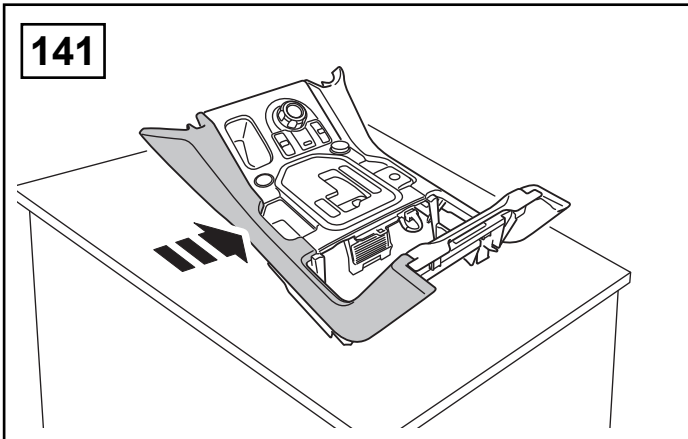
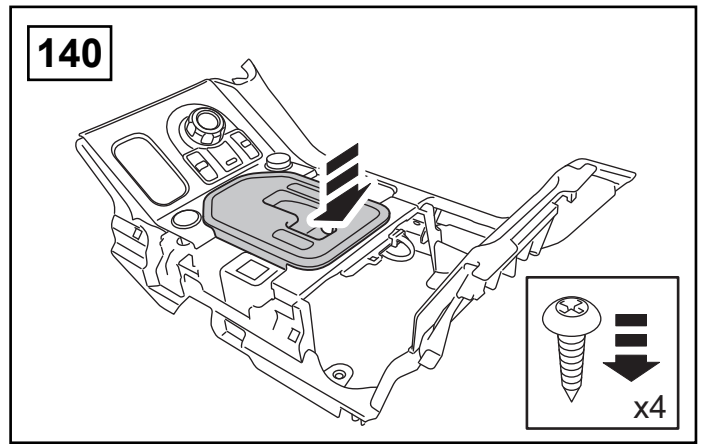
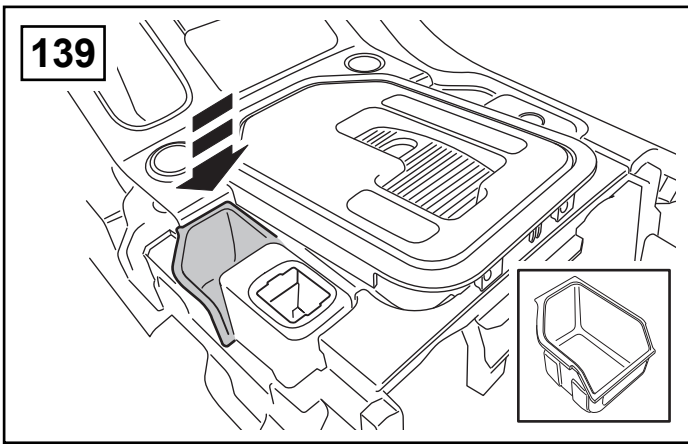
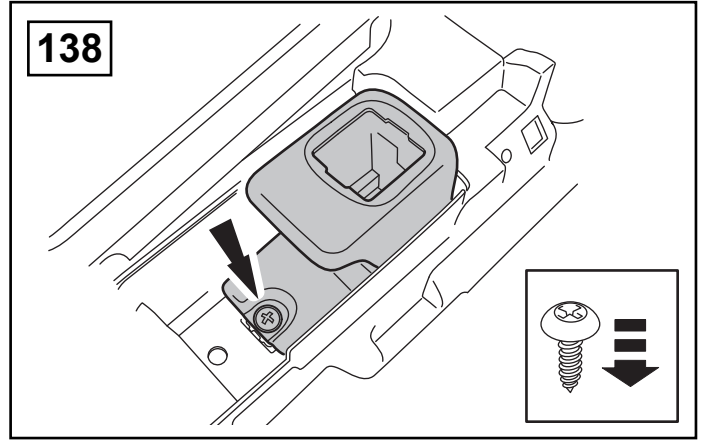
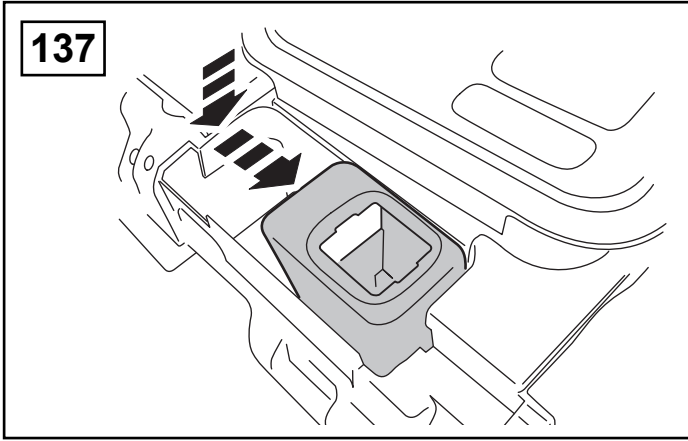

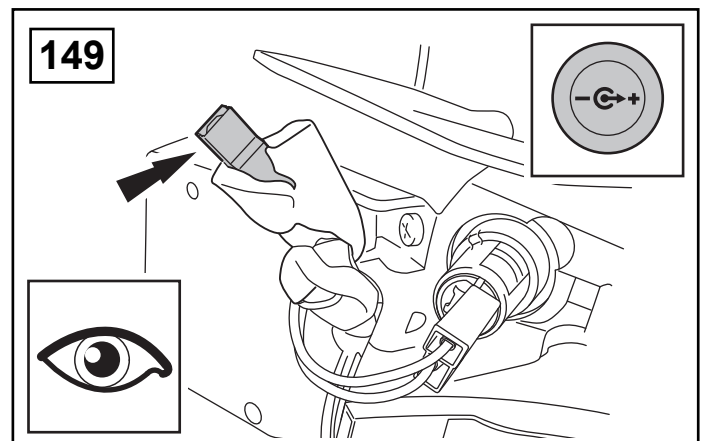
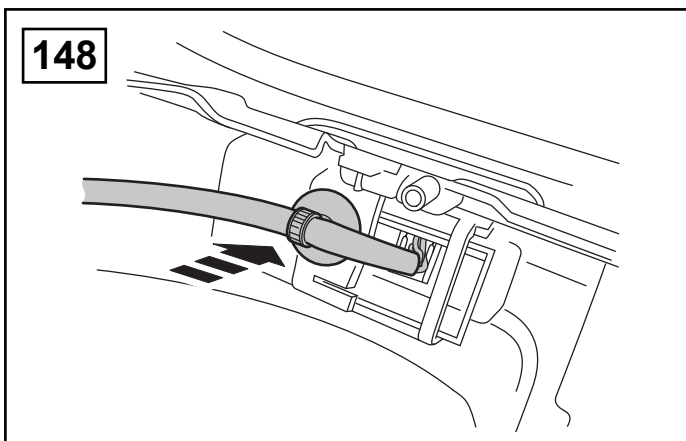
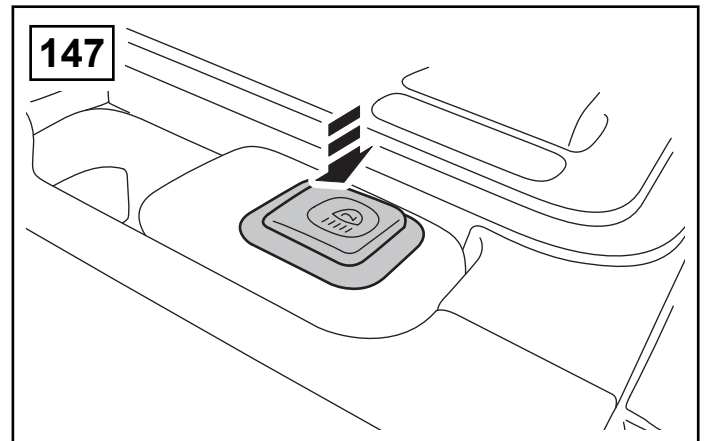
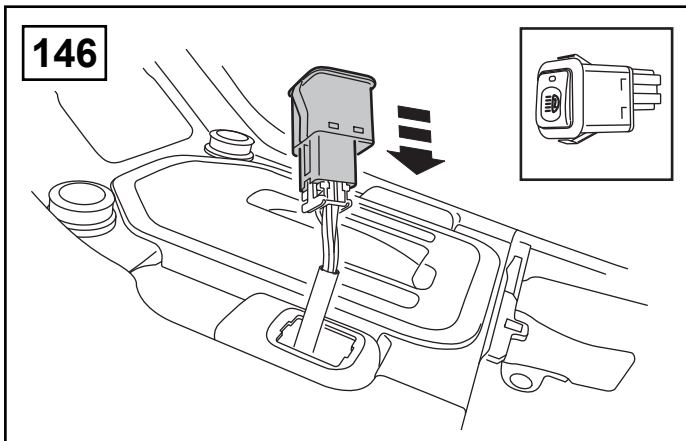
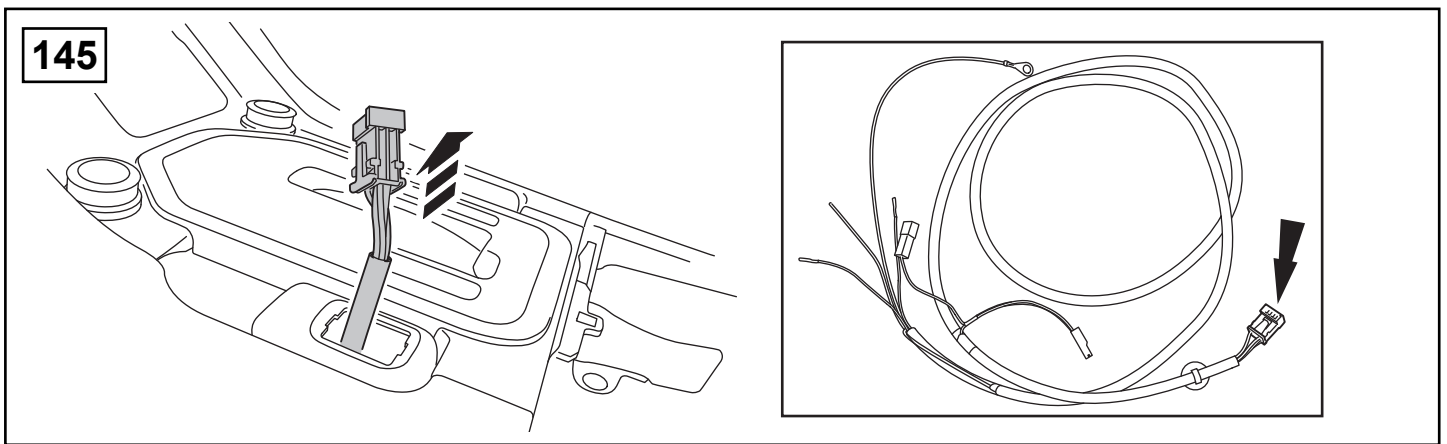
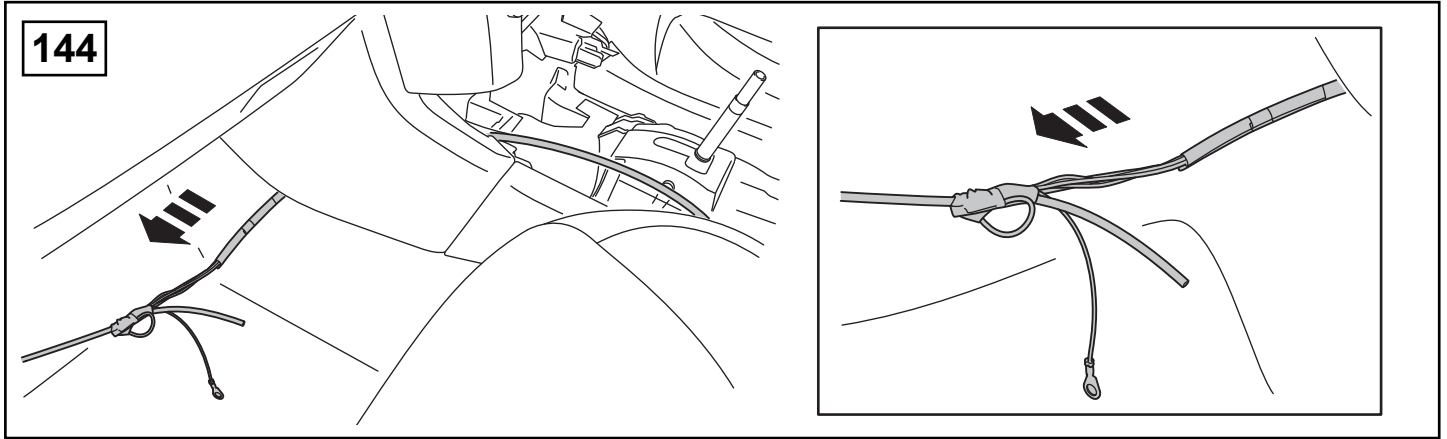

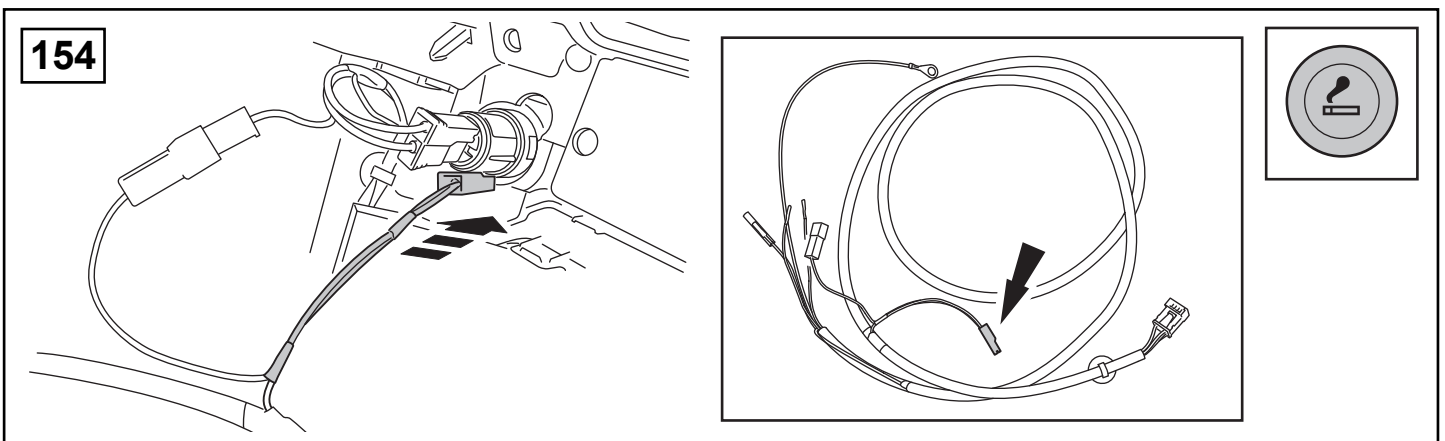
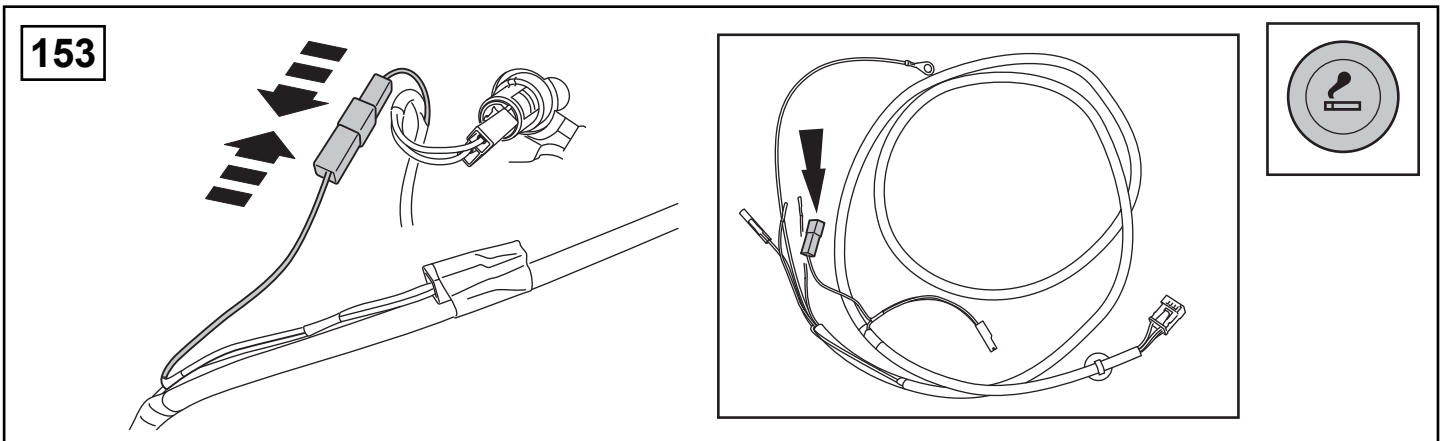
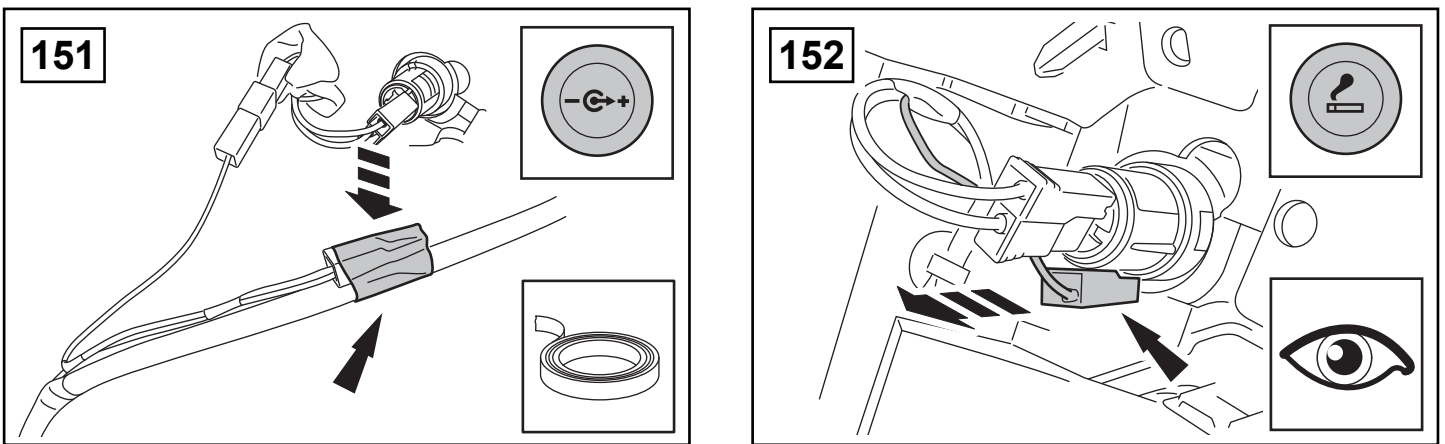
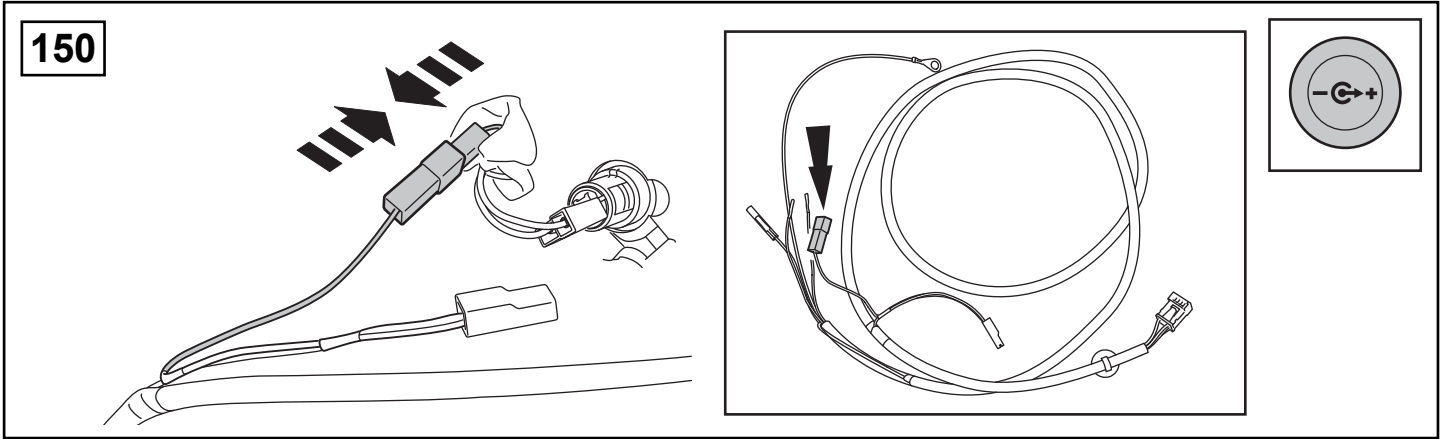

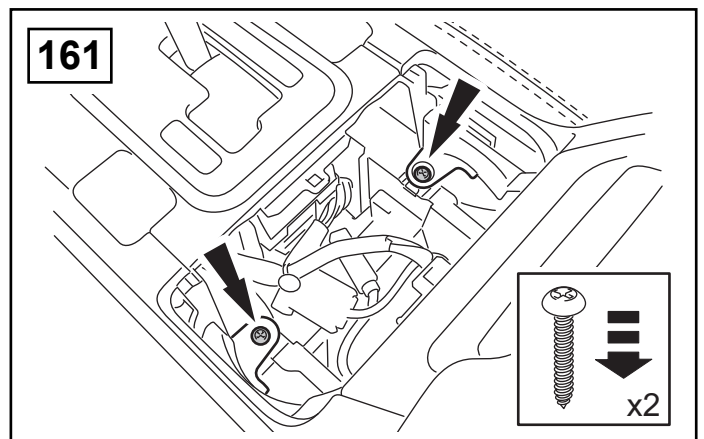
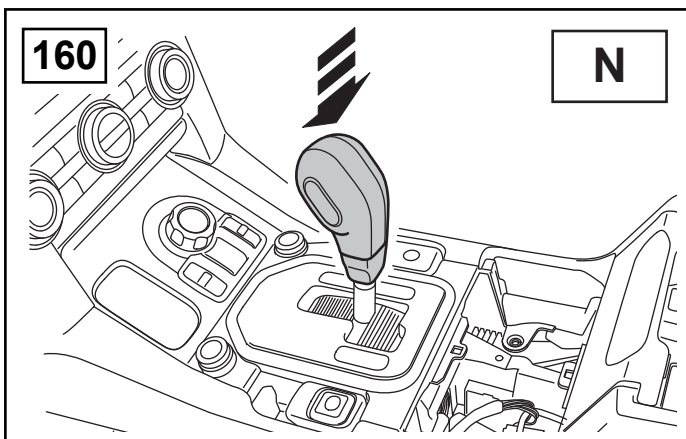
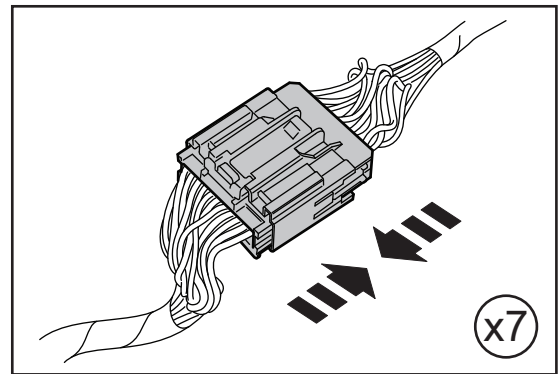
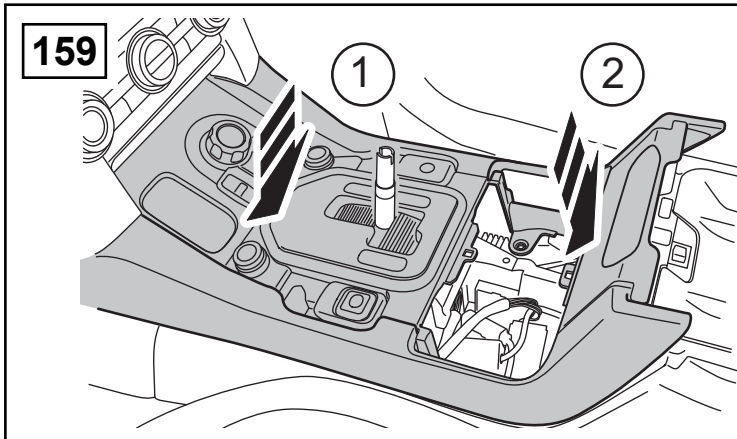
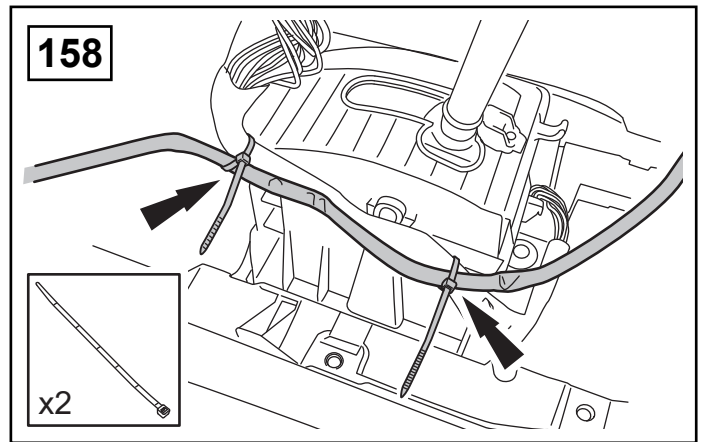
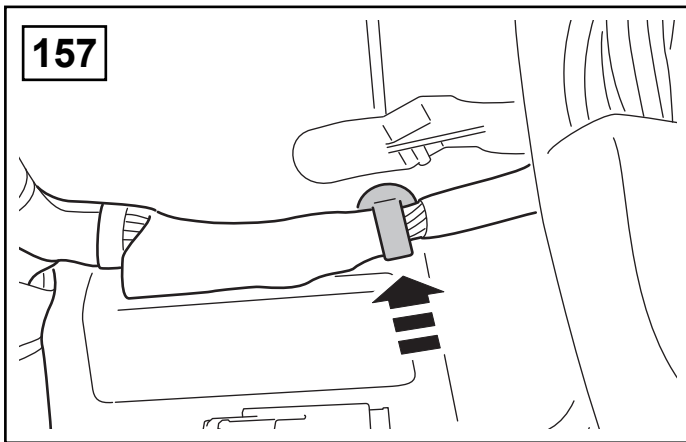
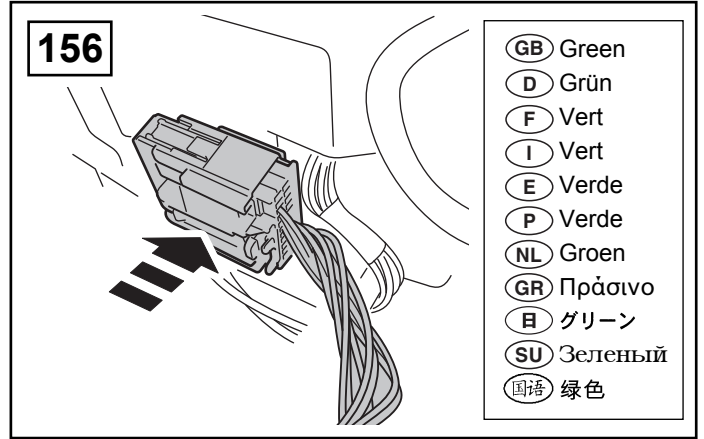
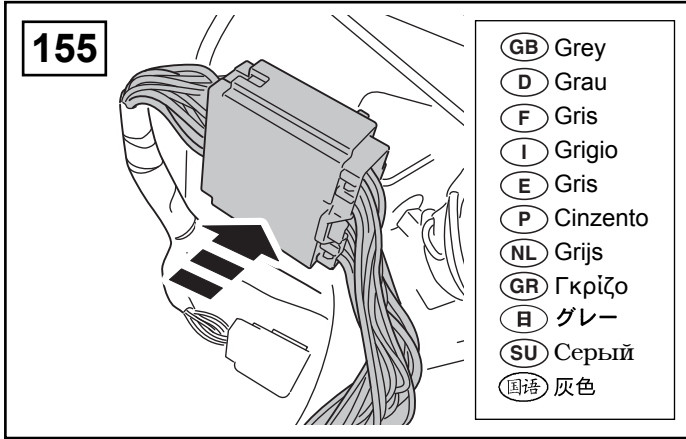

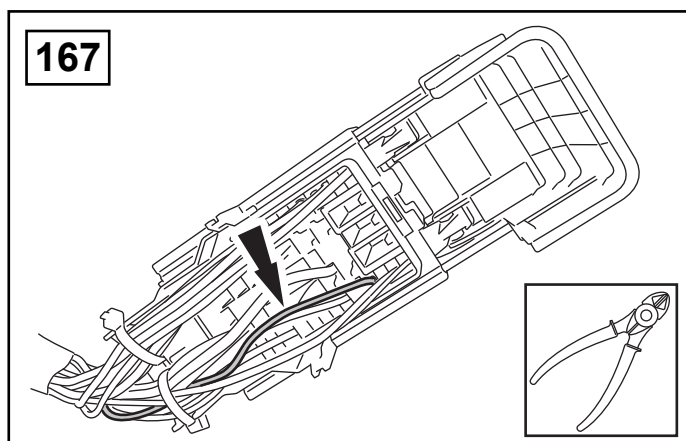
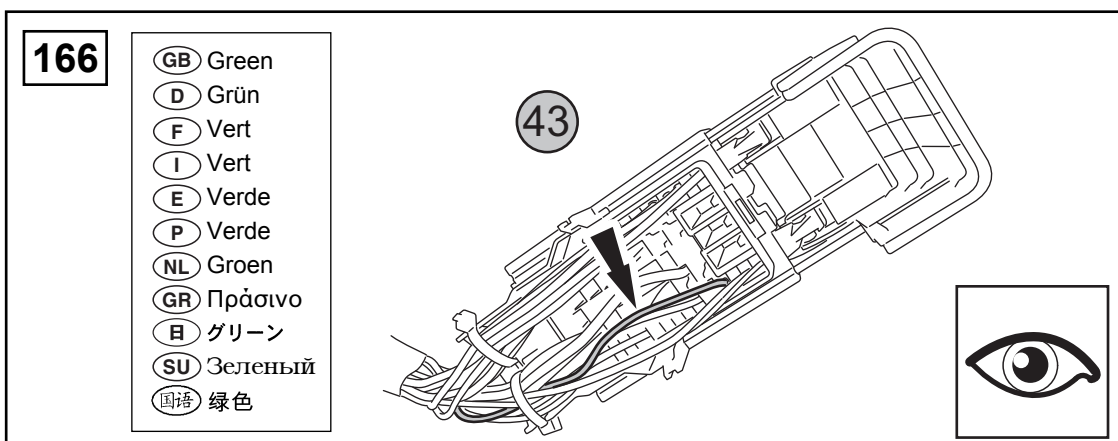
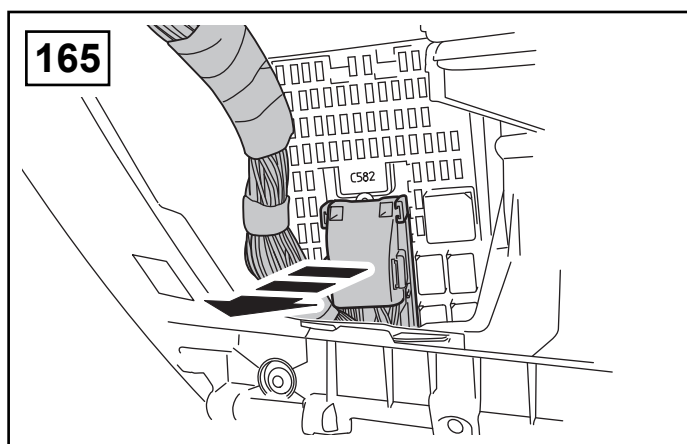
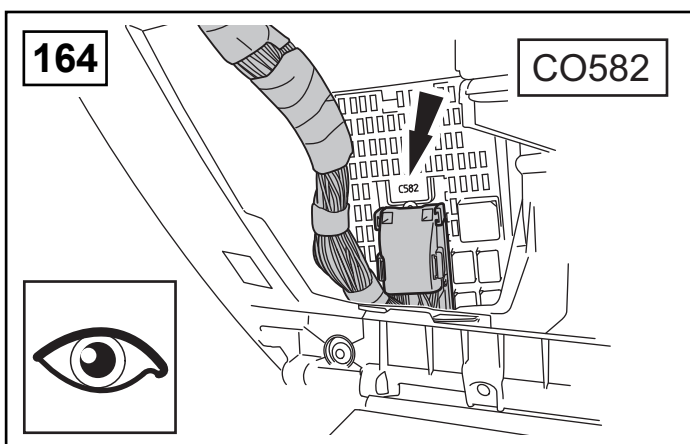
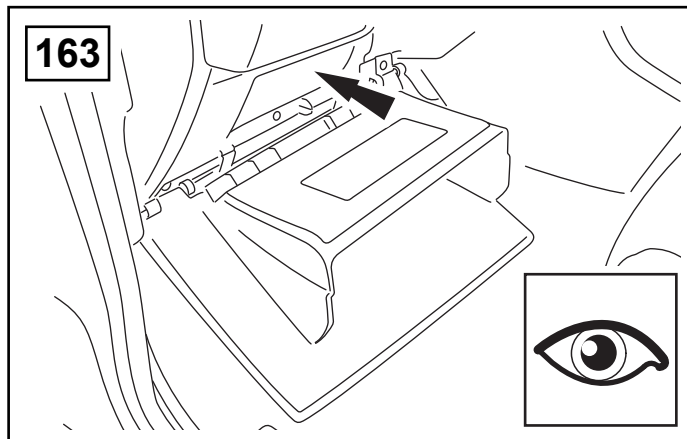
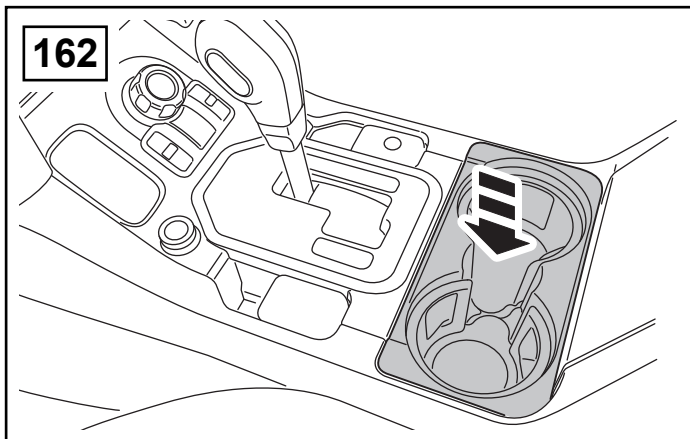

168

- (GB) Black
- (D) Schwarz
- (F) Noir
- (I) Negro
- (E) Nero
- (P) Preta
- (NL) Zwart
- (GR) Μαυρο
- (日) ブラック
- (SU) Черный
- (国) 黑色

170

171

C0580

172

173

174

175

GB	Red
D	Rot
F	Rouge
I	Rosse
E	Rojo
P	Vermelho
NL	Rood
GR	Κόκκινο
日	レッド
SU	Красный
国語	红色

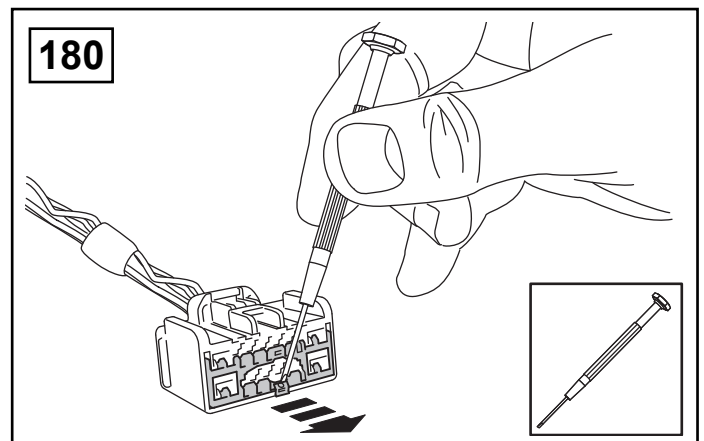
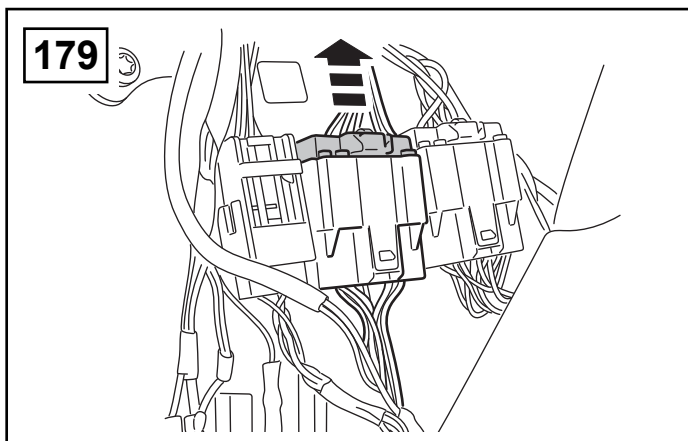
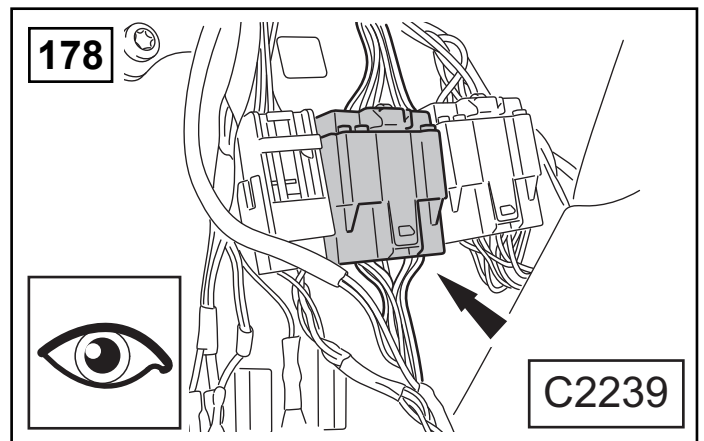
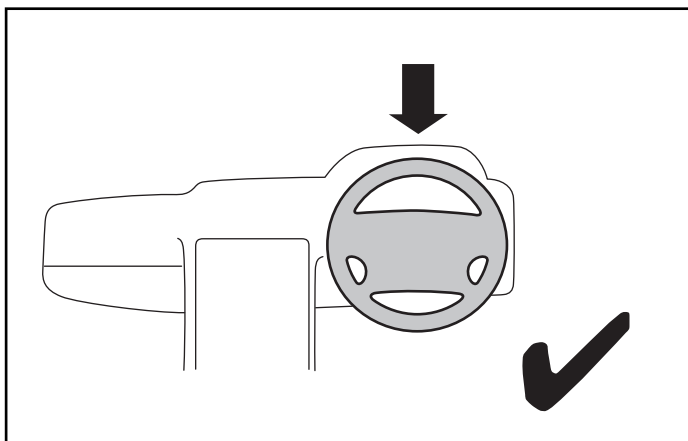
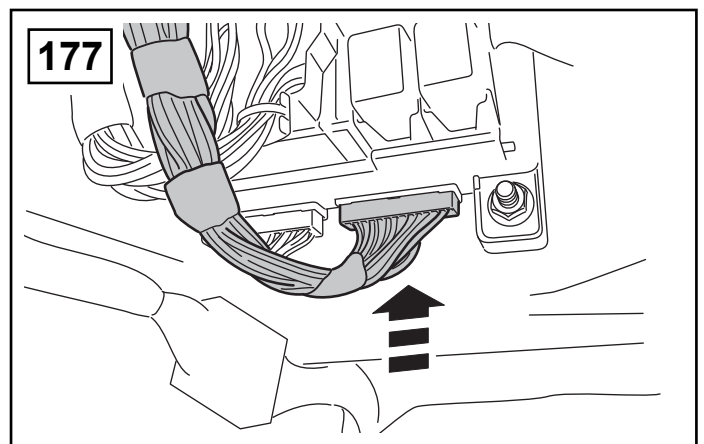
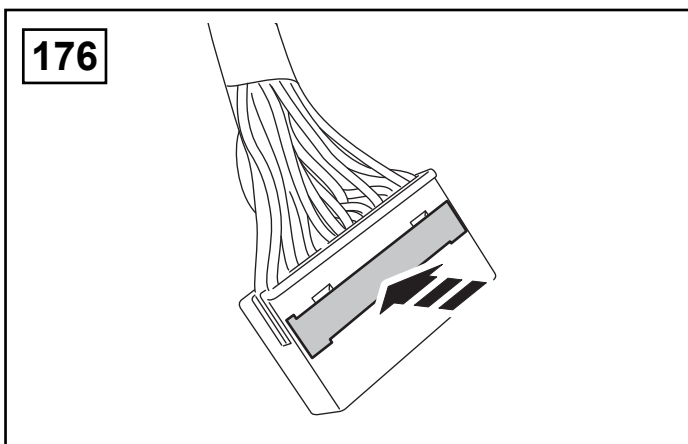

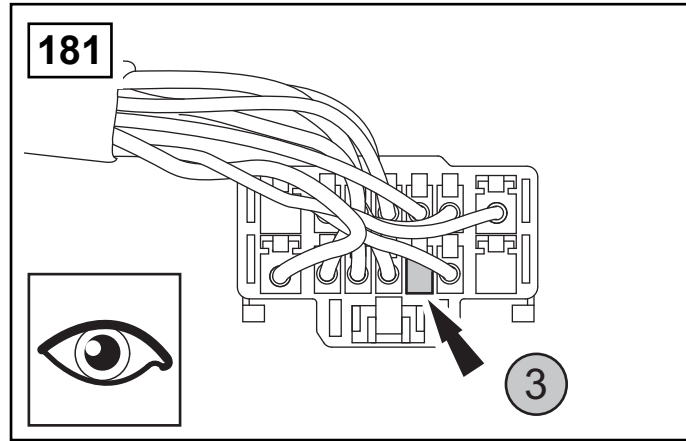

182

- (GB) Green/Yellow
- (D) Grün/Gelb
- (F) Vert/Jaune
- (I) Vert/Giallo
- (E) Verde/Amarillo
- (P) Verde/Amarelo
- (NL) Groen/Geel
- (GR) Πράσινο/Κίτρινο
- (日) グリーン/イエロー
- (SU) Зеленый/Желеный
- (国語) 绿色/黄色

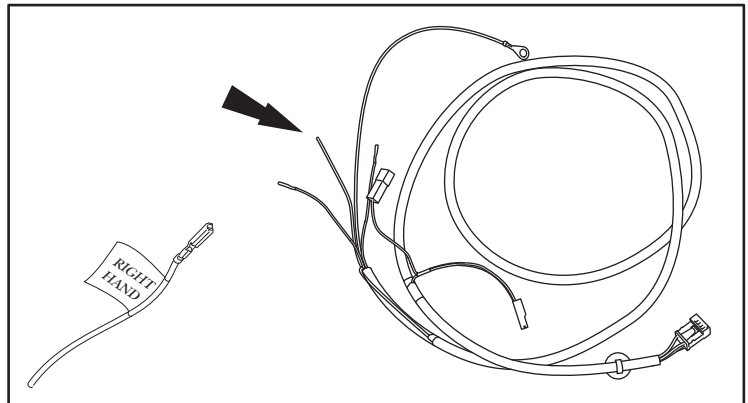

- (GB) RIGHT HAND DRIVE
- (D) RECHTSSTEUERUNG
- (F) CONDUITE A DROITE
- (I) VOLANTE A LA DERECHA
- (E) GUIDA A DESTRA
- (P) DIRECÇÃO À DIREITA
- (NL) RECHTSGESTUURDE VERSIES
- (GR) ΑΡΙΣΤΕΡΟΤΙΜΟΝΟ
- (日) 右ハンドル
- (SU) Правый привод
- (国語) 右座驾驶

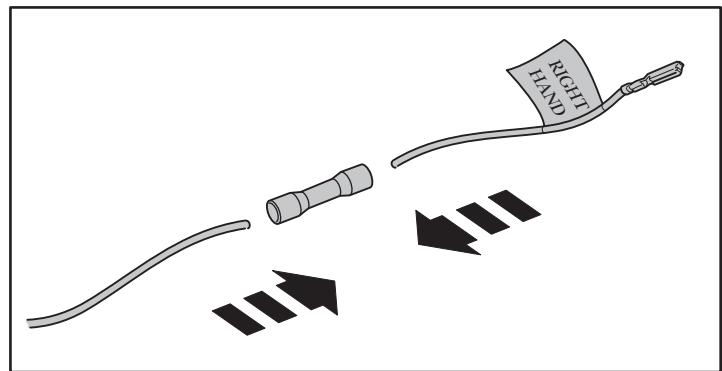

183

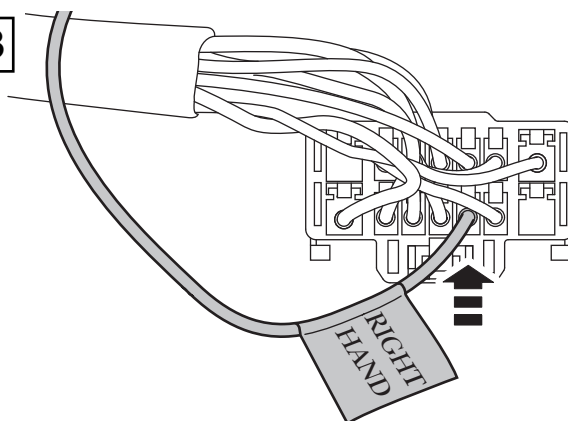

- (GB) Green/Yellow
- (D) Grün/Gelb
- (F) Vert/Jaune
- (I) Vert/Giallo
- (E) Verde/Amarillo
- (P) Verde/Amarelo
- (NL) Groen/Geel
- (GR) Πράσινο/Κίτρινο
- (日) グリーン/イエロー
- (SU) Зеленый/Желеный
- (国語) 绿色/黄色

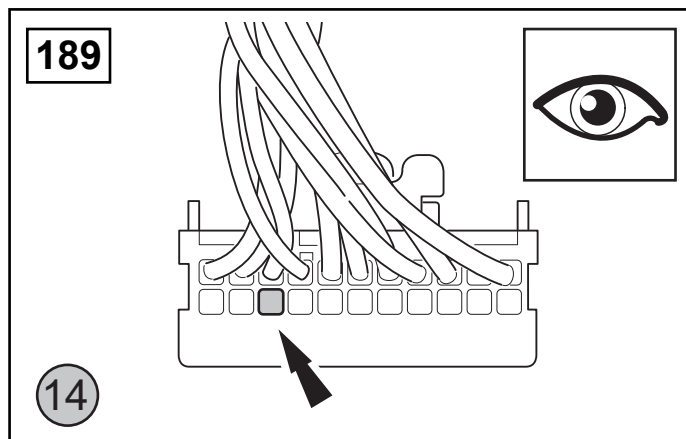
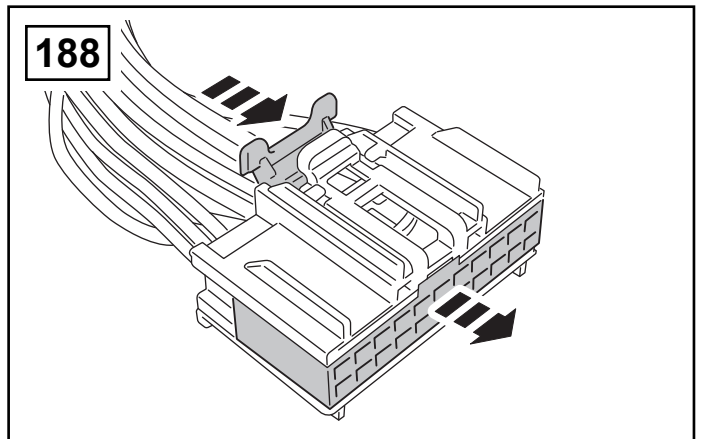
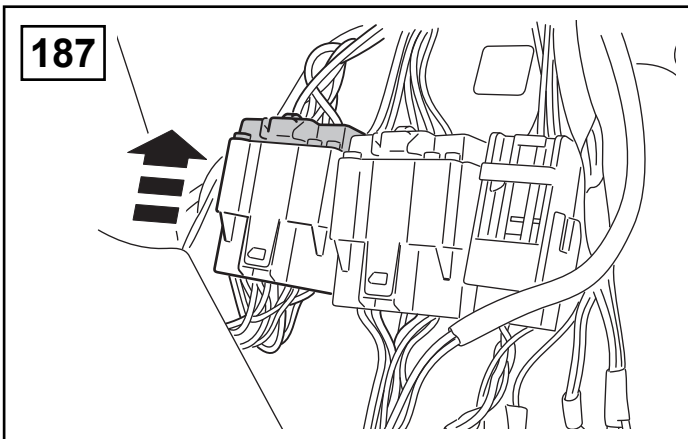
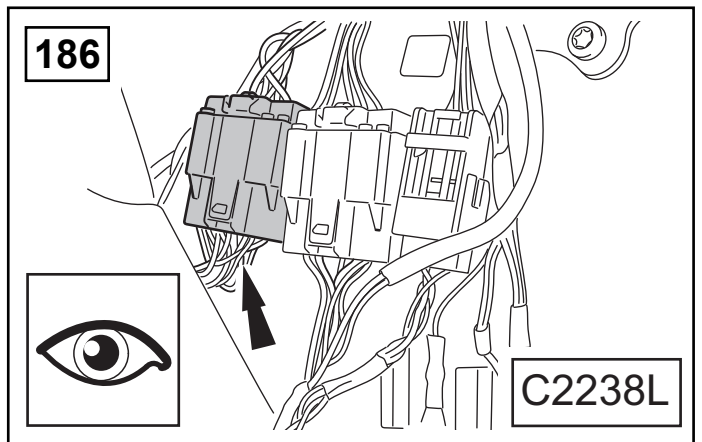
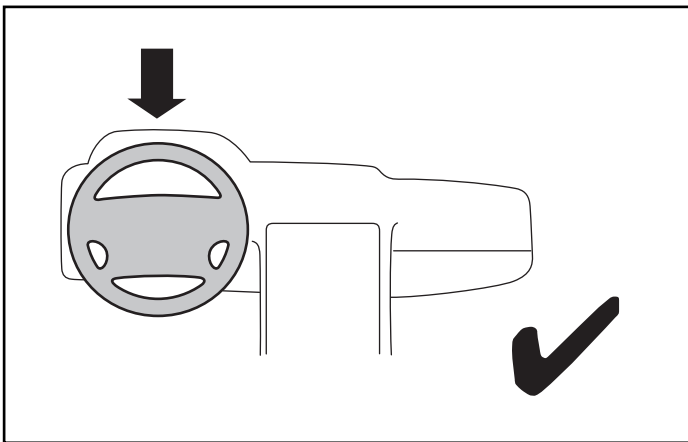
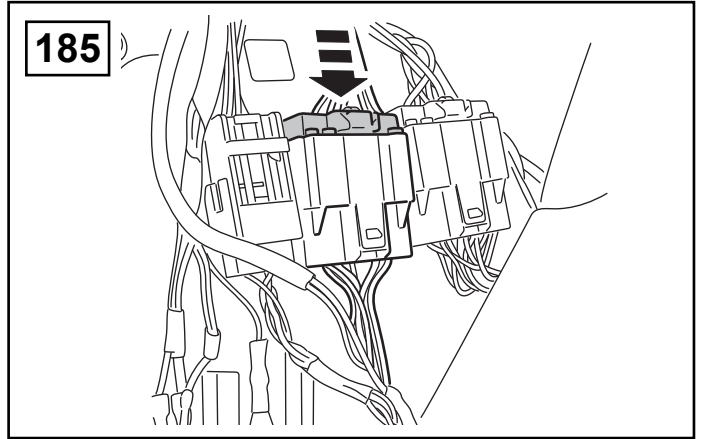
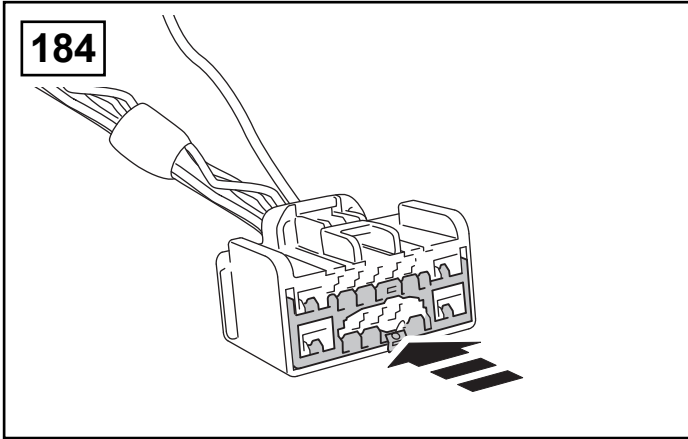

190

- (GB) Green/Yellow
- (D) Grün/Gelb
- (F) Vert/Jaune
- (I) Vert/Giallo
- (E) Verde/Amarillo
- (P) Verde/Amarelo
- (NL) Groen/Geel
- (GR) Πράσινο/Κίτρινο
- (日) グリーン/イエロー
- (SU) Зеленый/Желеный
- (国語) 绿色/黄色

- (GB) LEFT HAND DRIVE
- (D) LINKSSTEUERUNG
- (F) CONDUITE A GAUCHE
- (I) VOLANTE A LA IZQUIERDA
- (E) GUIDA A SINISTRA
- (P) DIRECÇÃO À ESQUERDA
- (NL) LINKSGESTUURDE VERSIES
- (GR) ΔΕΞΙΟΤΙΜΟΝΟ
- (日) 左ハンドル
- (SU) Левый привод
- (国語) 左座驾驶

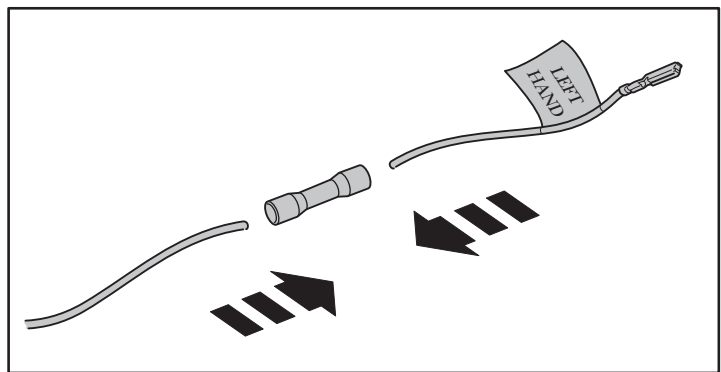
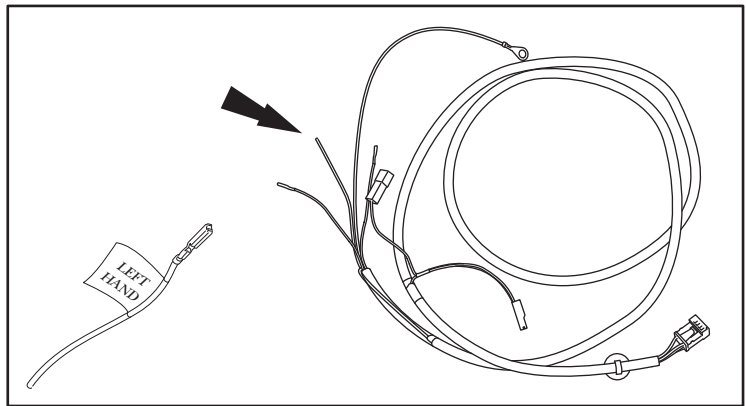

191

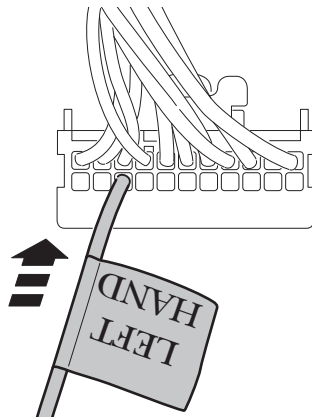

- (GB) Green/Yellow
- (D) Grün/Gelb
- (F) Vert/Jaune
- (I) Vert/Giallo
- (E) Verde/Amarillo
- (P) Verde/Amarelo
- (NL) Groen/Geel
- (GR) Πράσινο/Κίτρινο
- (日) グリーン/イエロー
- (SU) Зеленый/Желеный
- (国語) 绿色/黄色

192

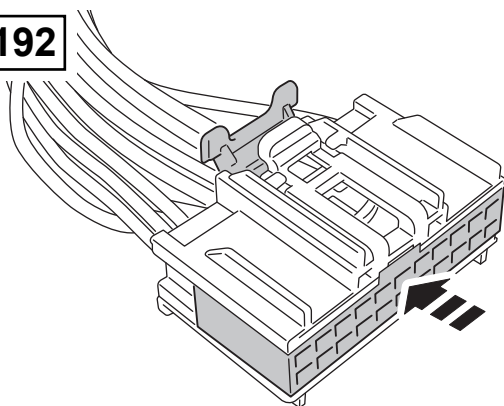

193

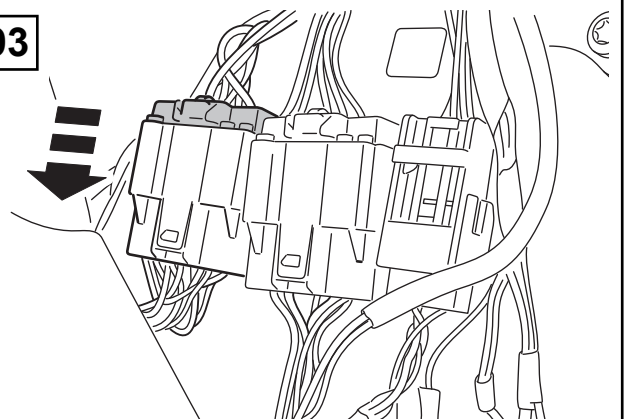

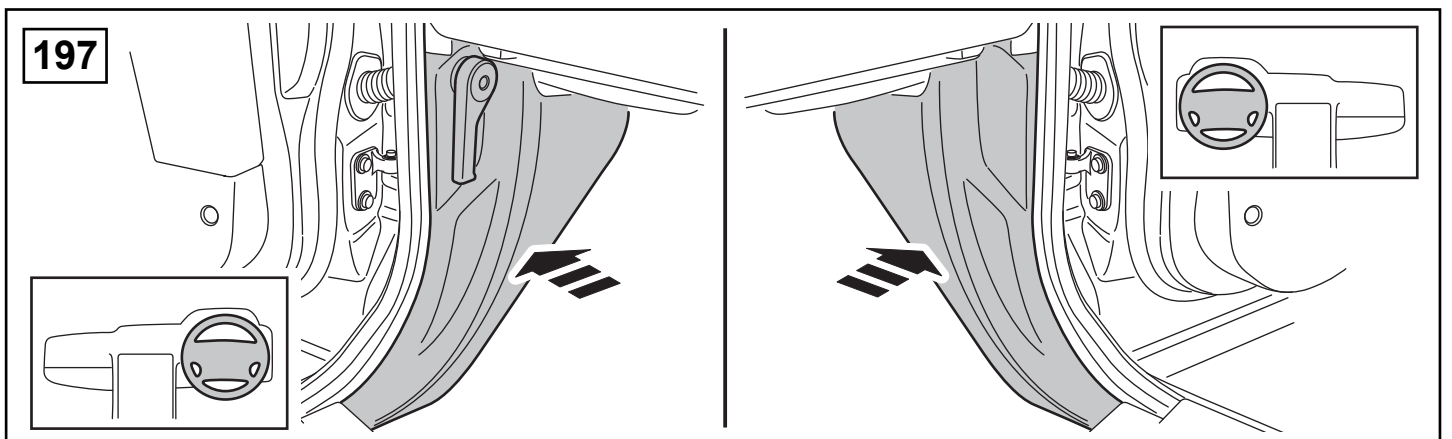
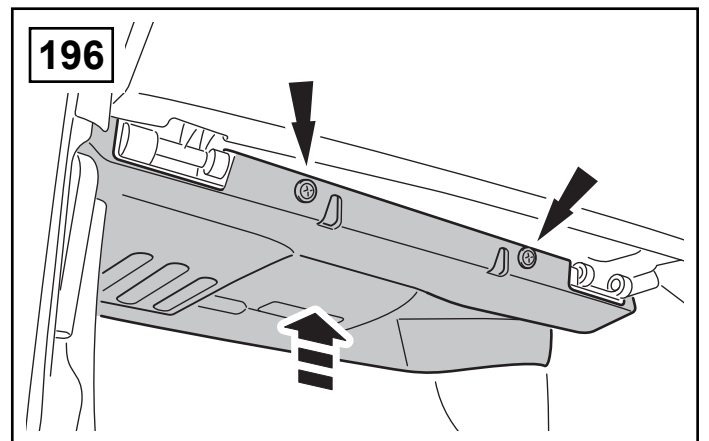
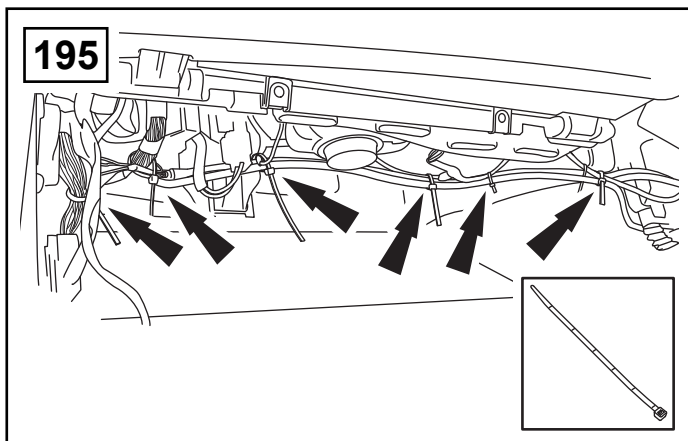
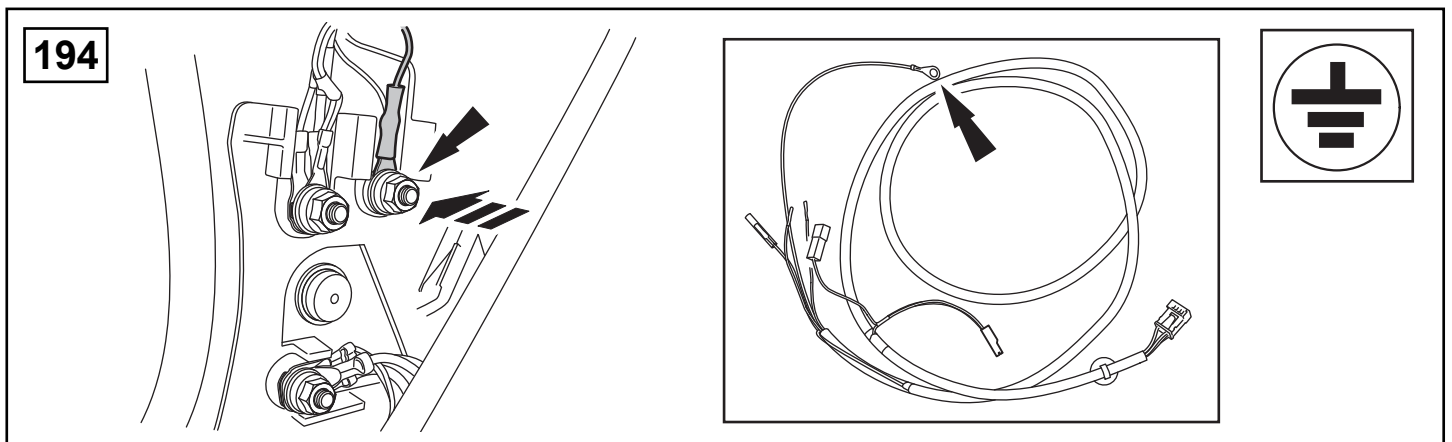
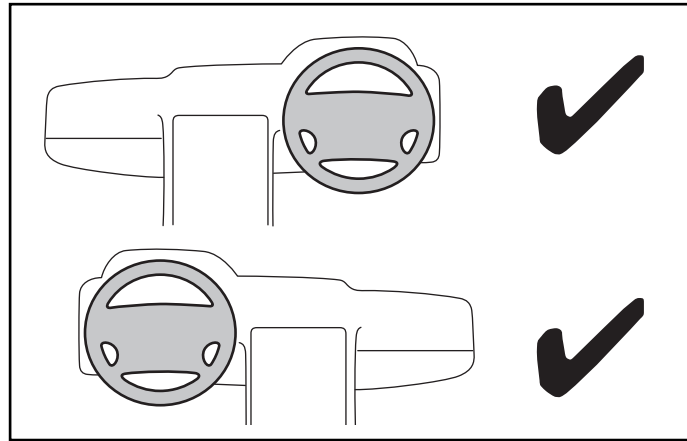

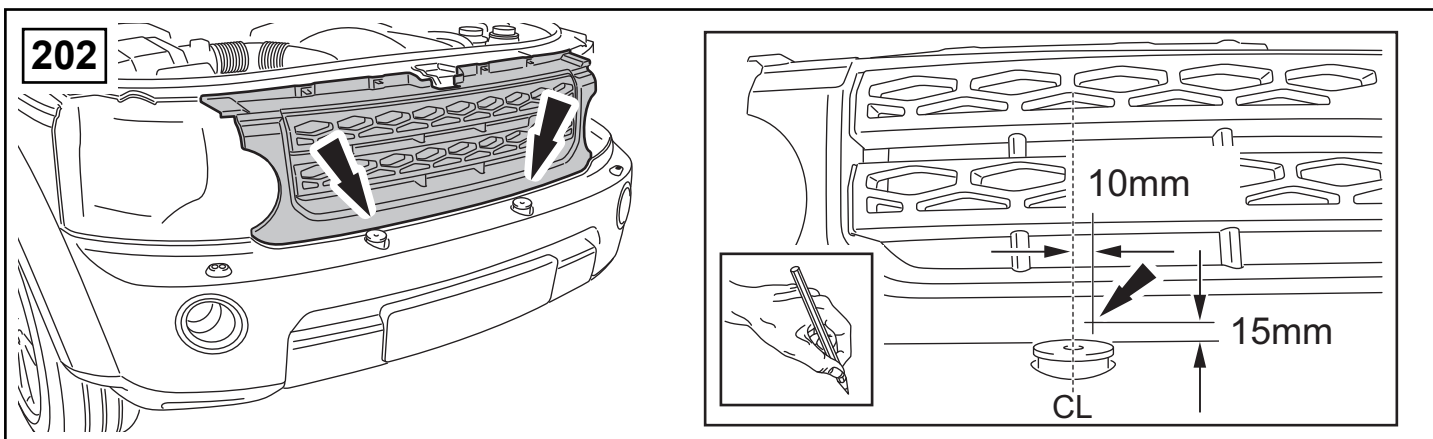
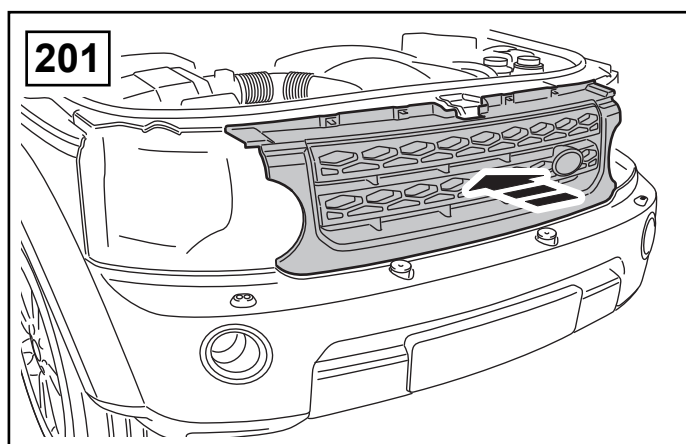
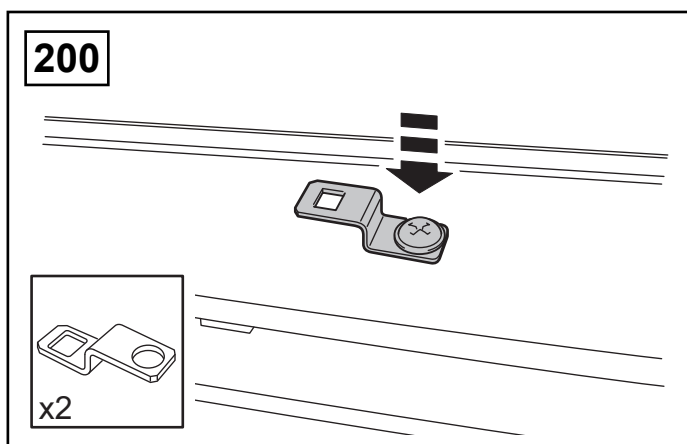
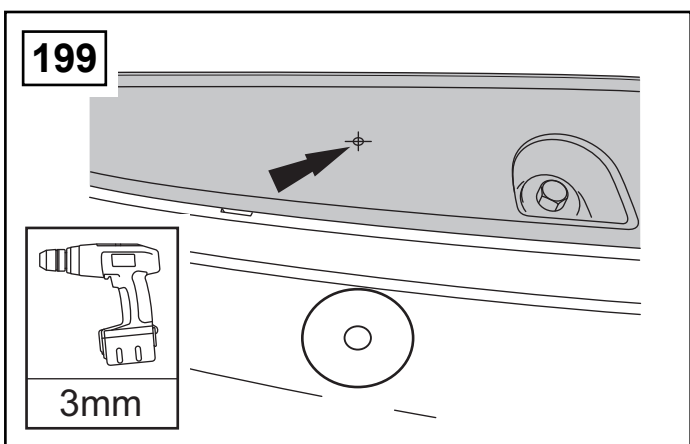
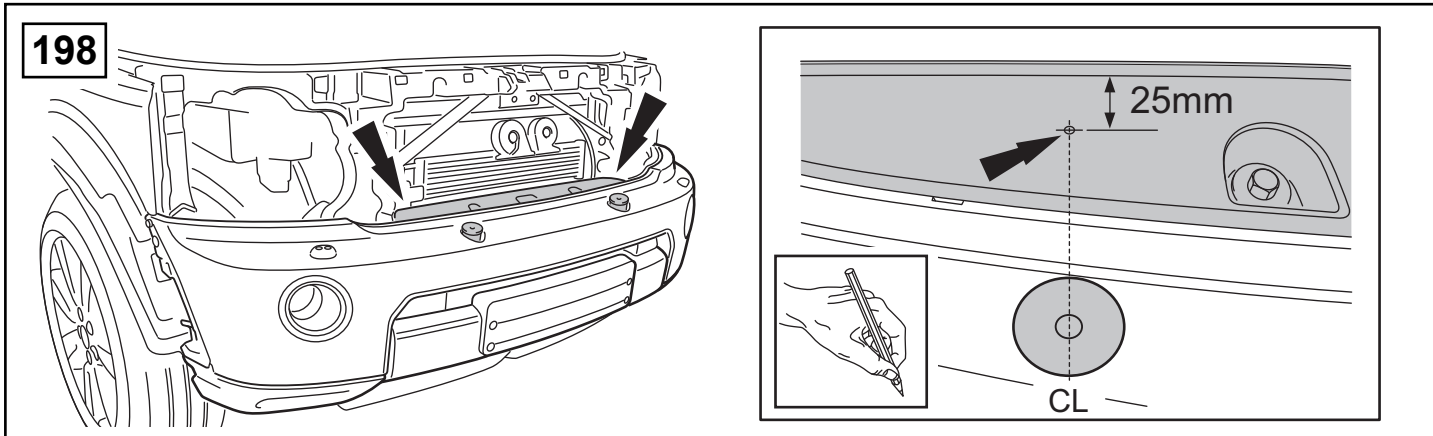

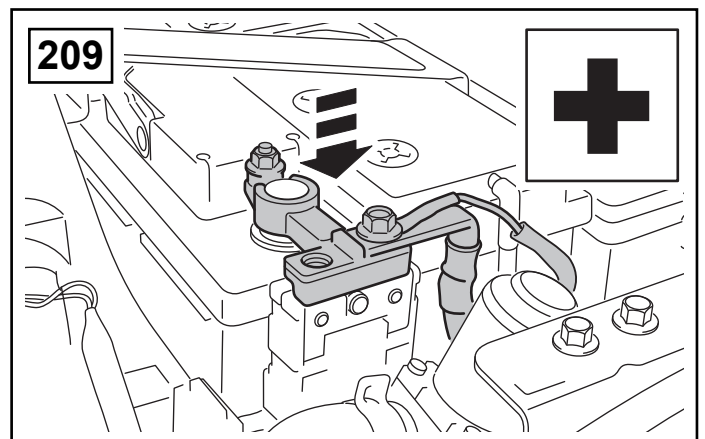
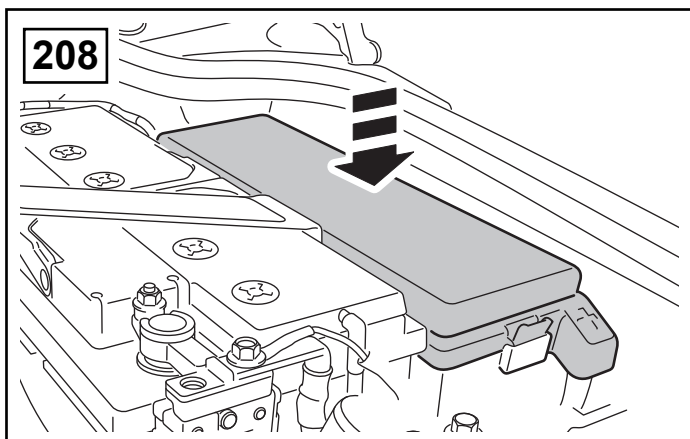
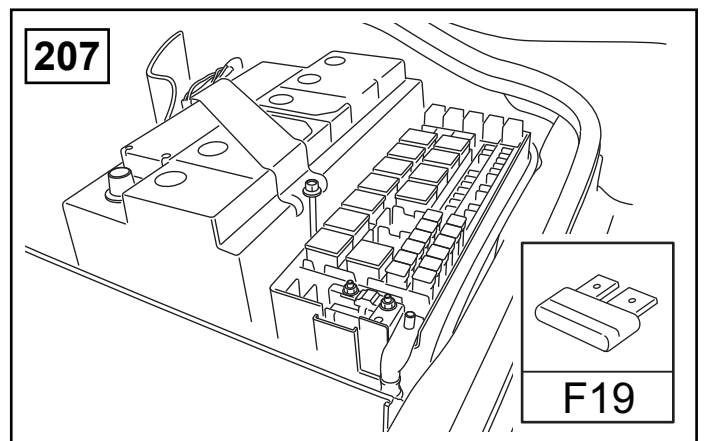
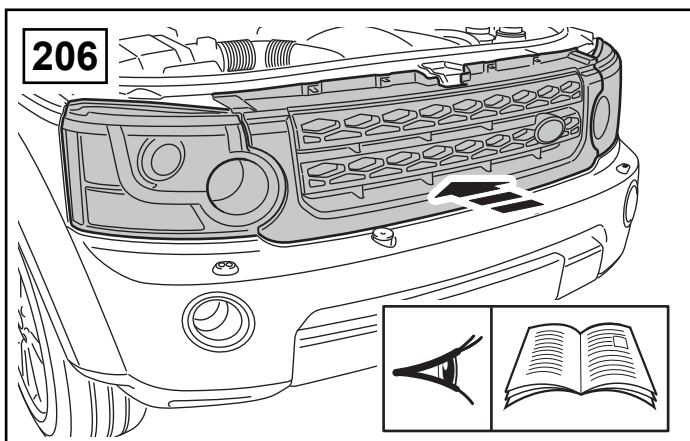
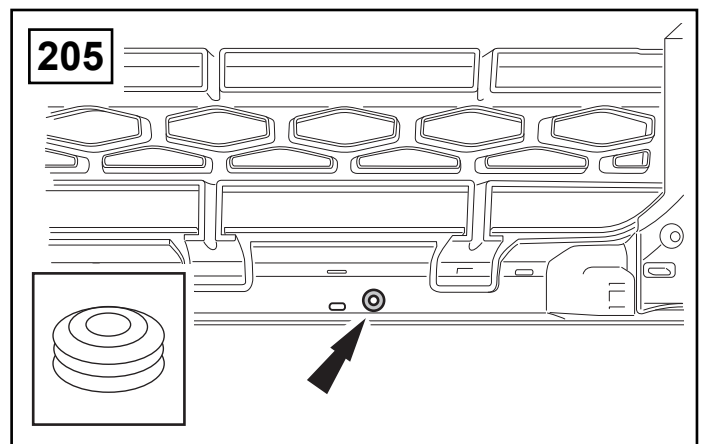
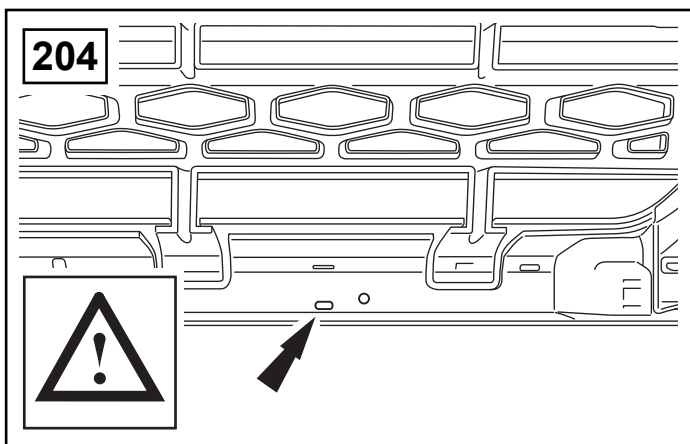
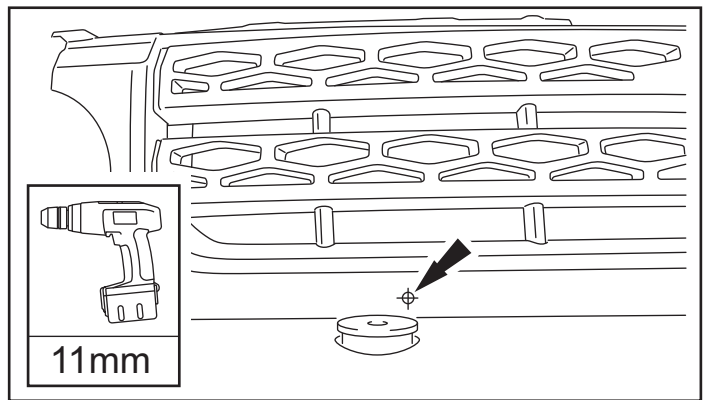
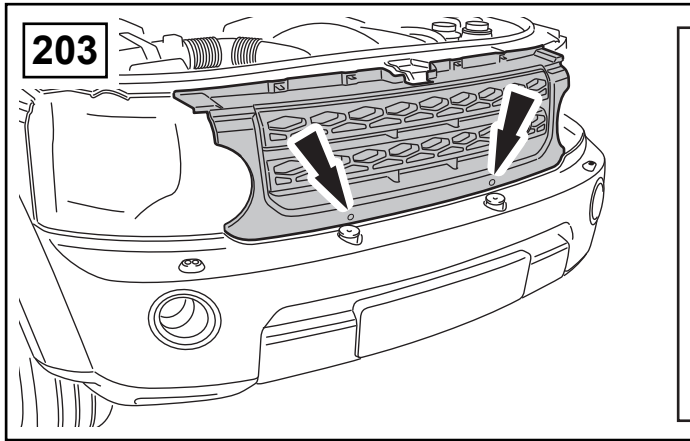

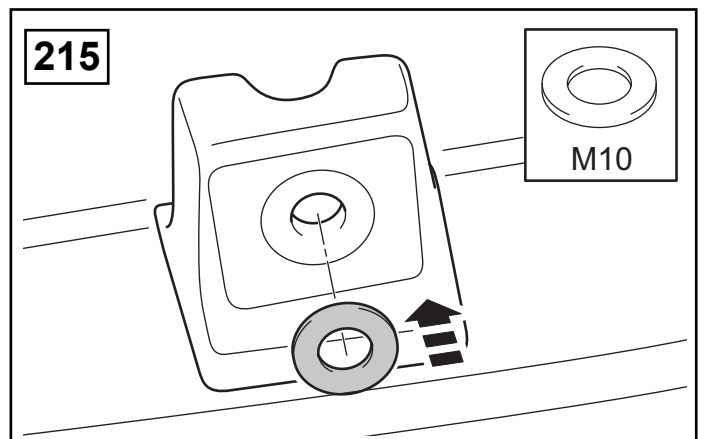
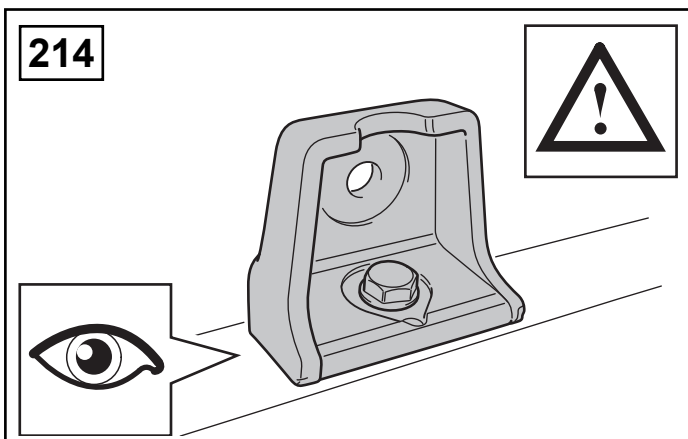
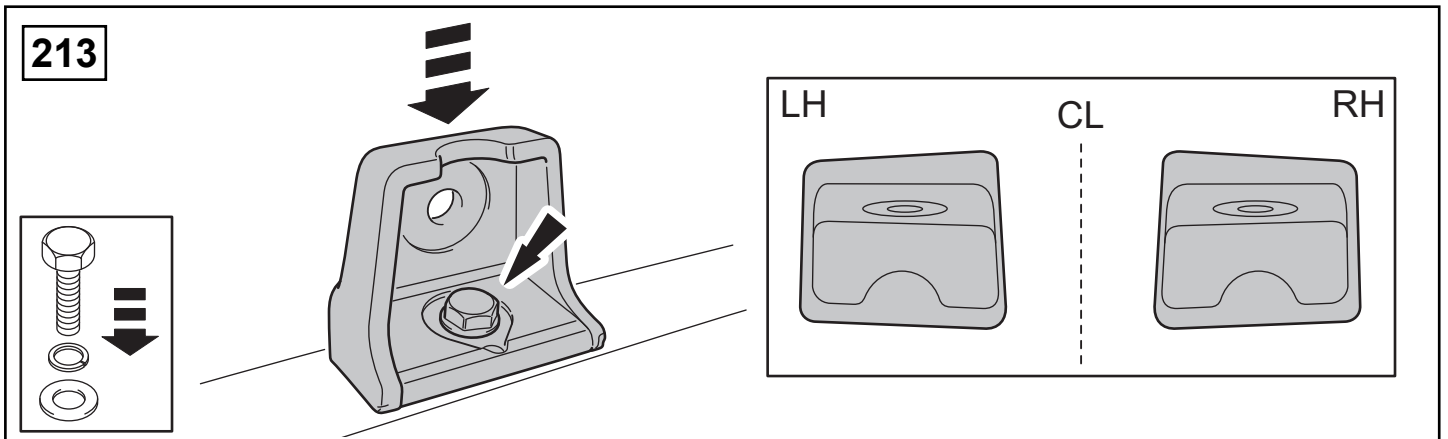
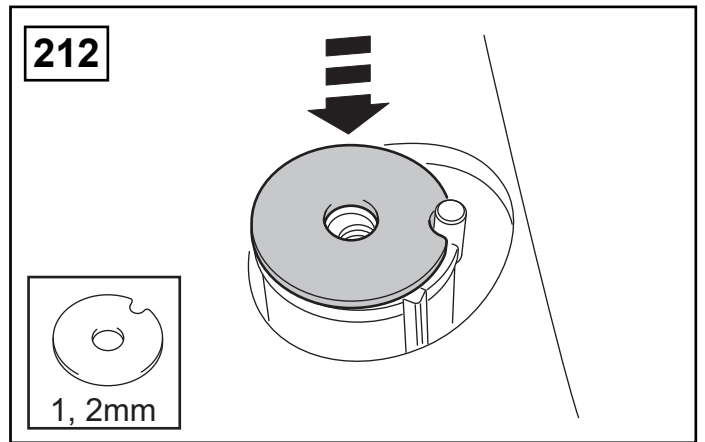
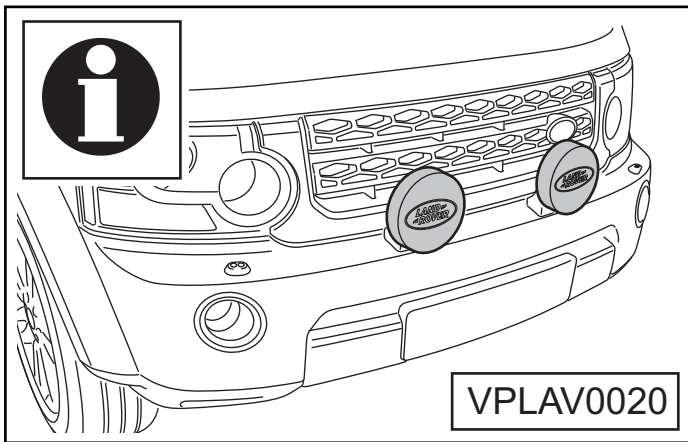
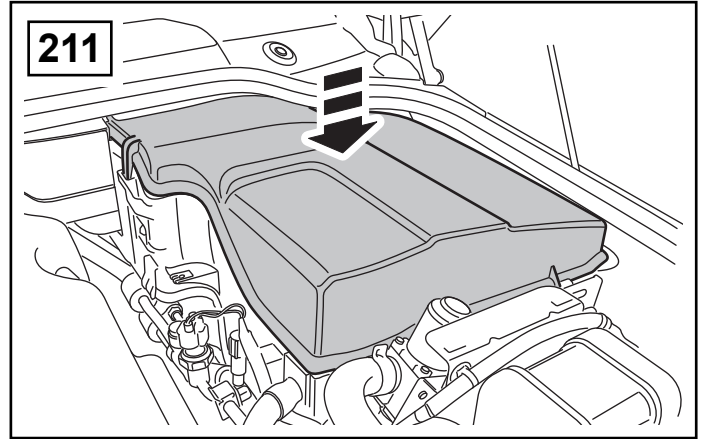
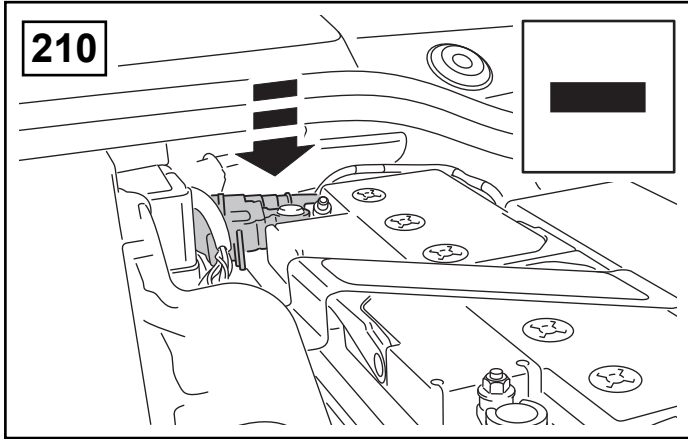

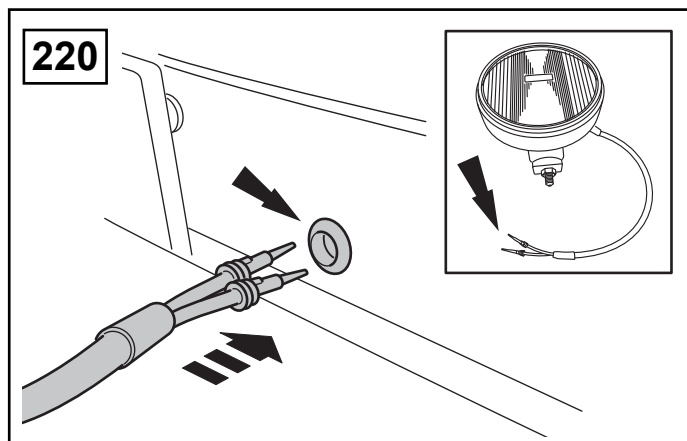
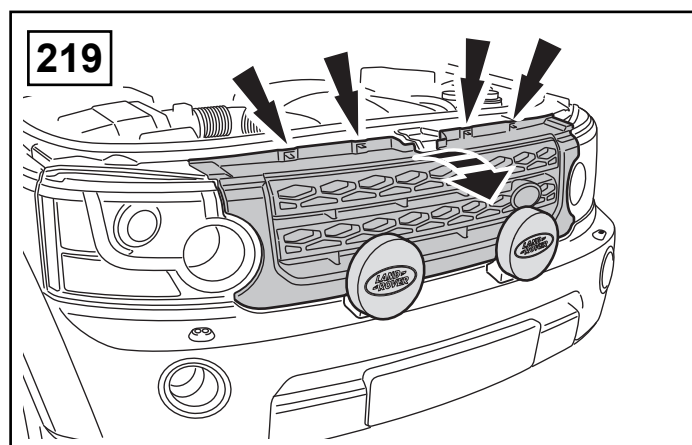
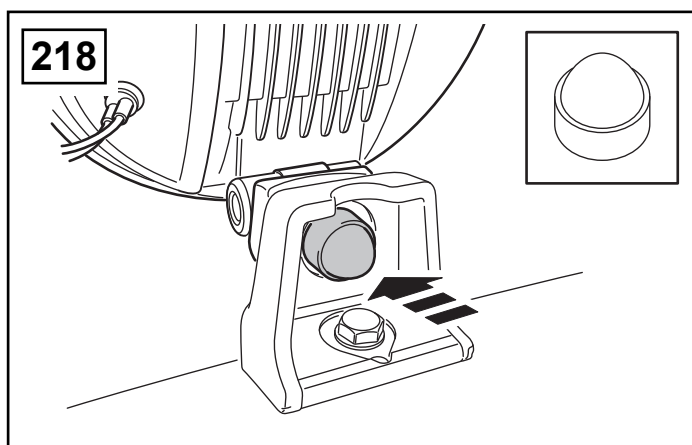
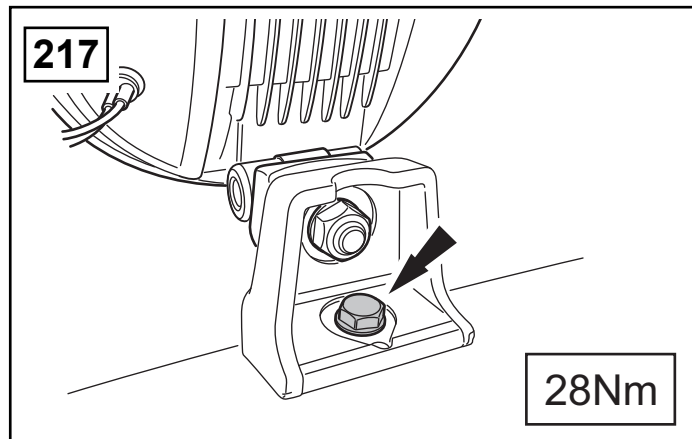
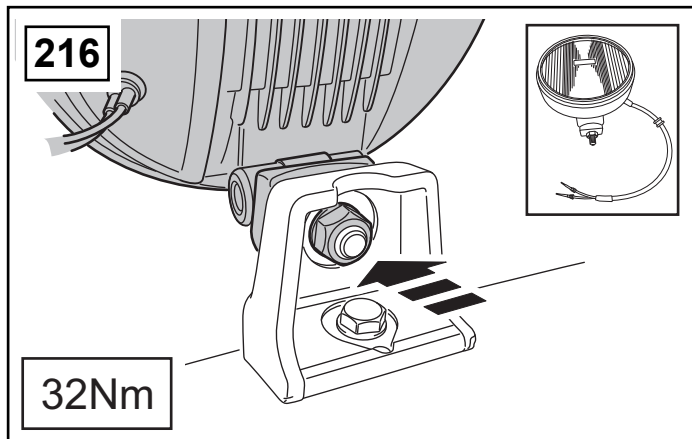

221

1	(GB) White	(GB) Black
	(D) Weiß	(D) Schwarz
	(F) Blanc	(F) Noir
	(I) Bianco	(I) Negro
	(E) Blanco	(E) Nero
	(P) Branco	(P) Preta
	(NL) Wit	(NL) Zwart
	(GR) Ασπρο	(GR) Μαυρο
	(日) ホワイト	(日) ブラック
	(SU) Белый	(SU) Черный
	(国語) 白色	(国語) 黒色

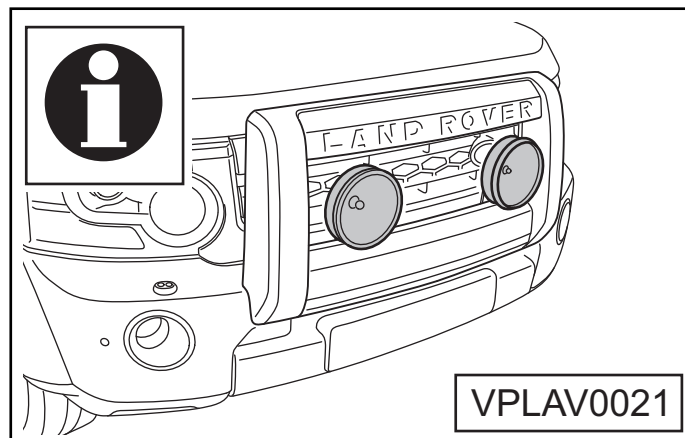
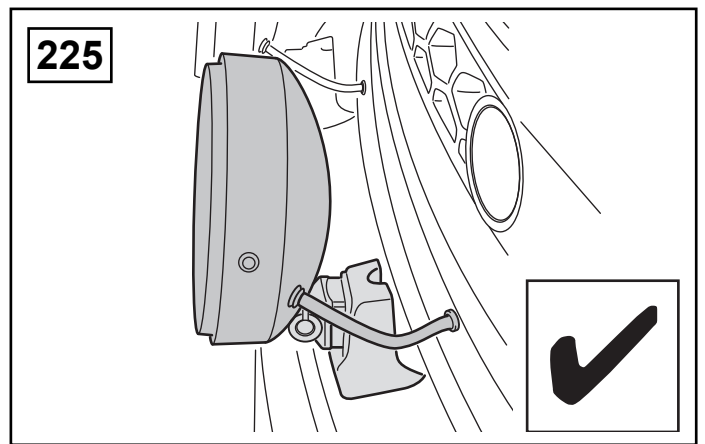
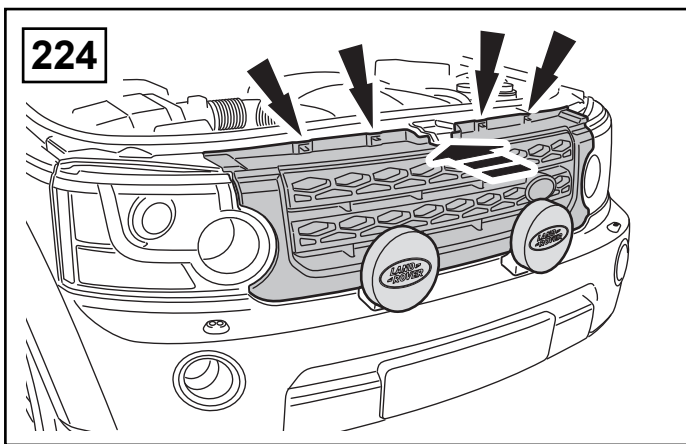
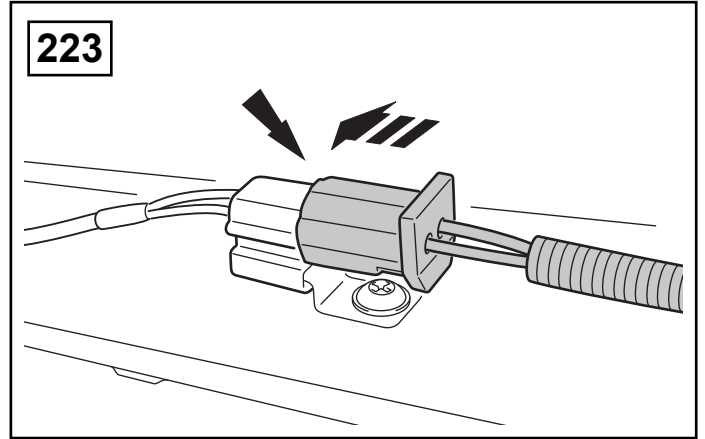
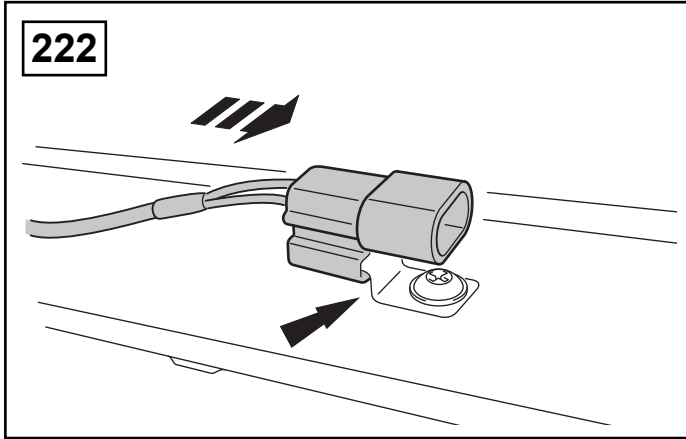

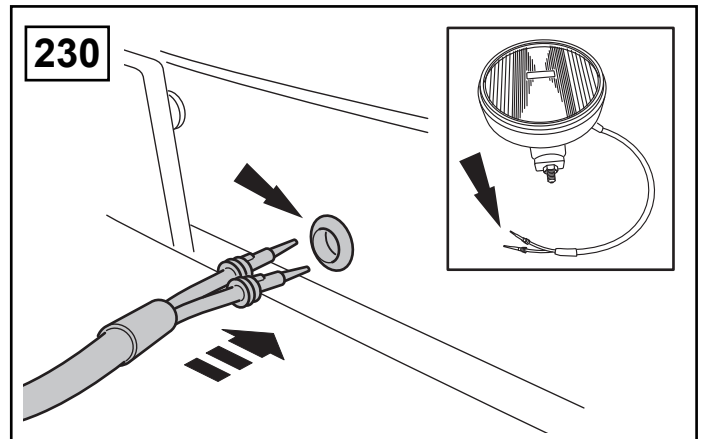
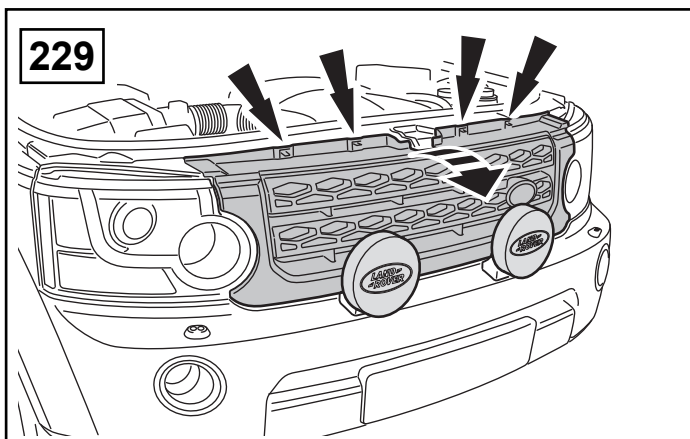
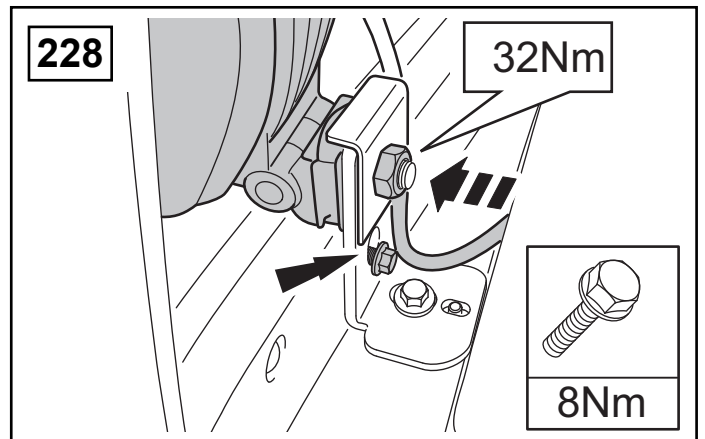
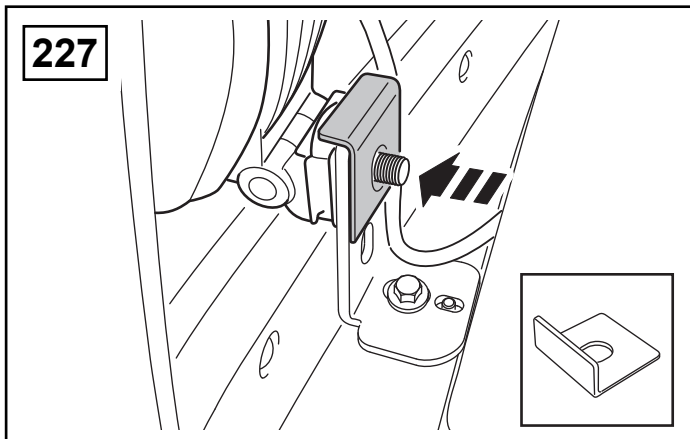
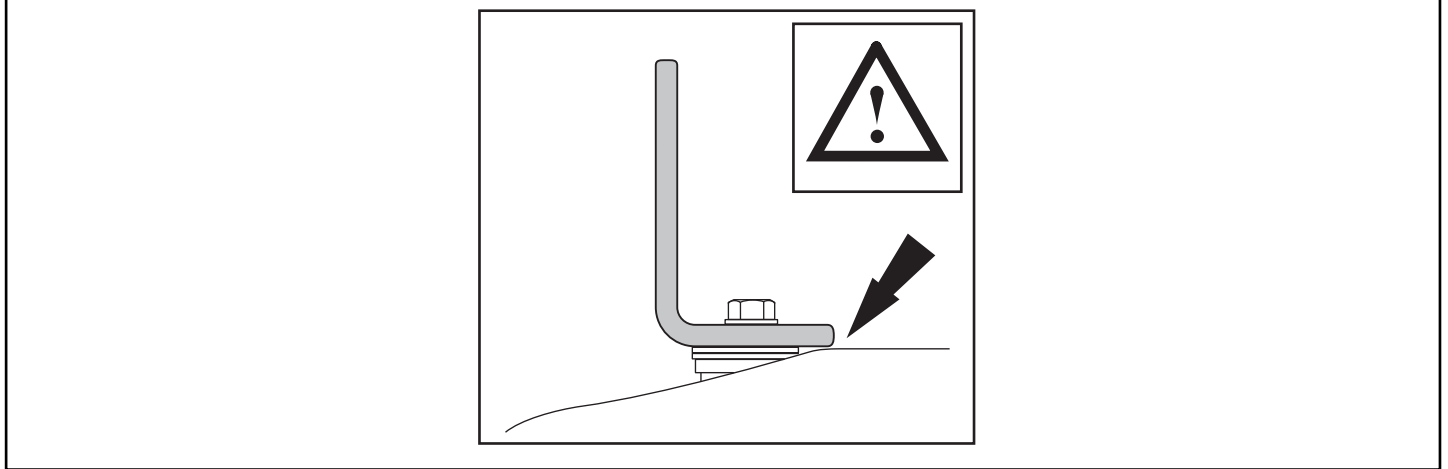
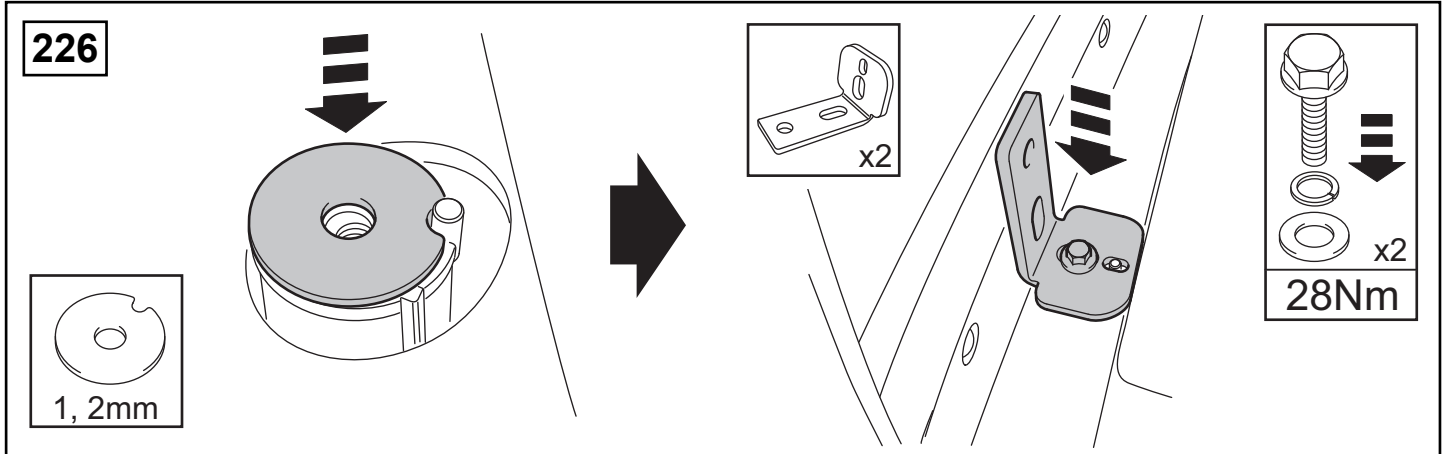

231

1

- (GB) White
- (D) Weiß
- (F) Blanc
- (I) Bianco
- (E) Blanco
- (P) Branco
- (NL) Wit
- (GR) Ασπρο
- (日) ホワイト
- (SU) Белый
- (国译) 白色

2

- (GB) Black
- (D) Schwarz
- (F) Noir
- (I) Negro
- (E) Nero
- (P) Preta
- (NL) Zwart
- (GR) Μαυρο
- (日) ブラック
- (SU) Черный
- (国译) 黑色

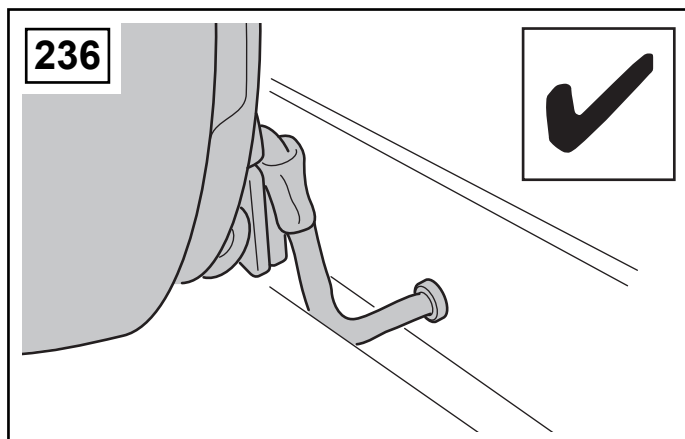
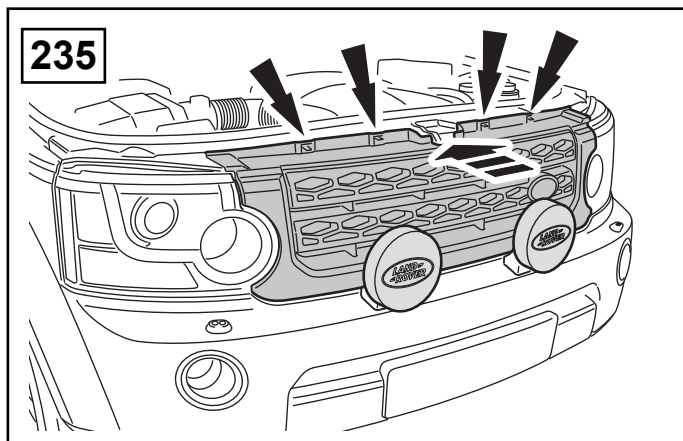
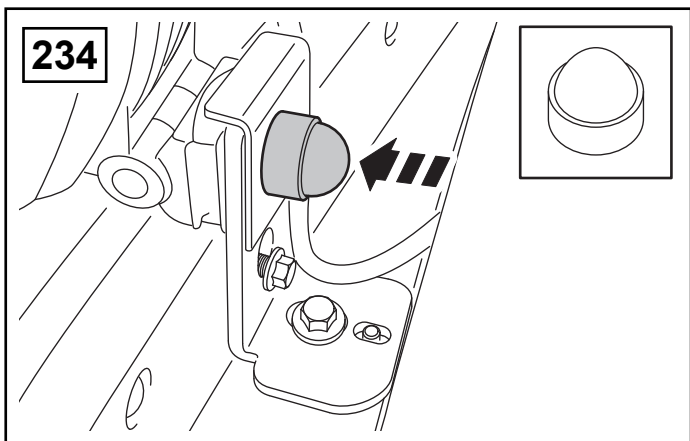
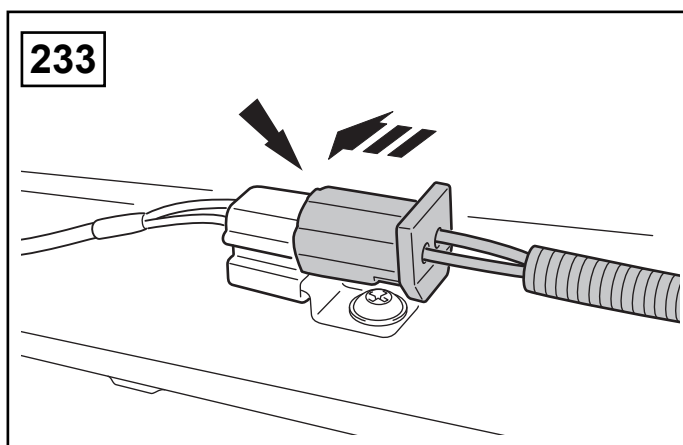
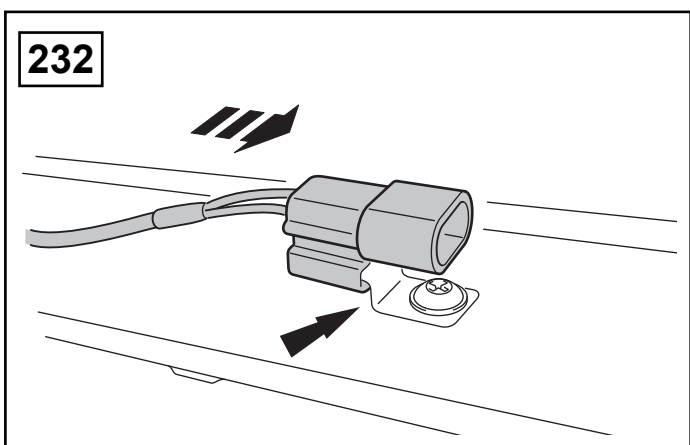



237

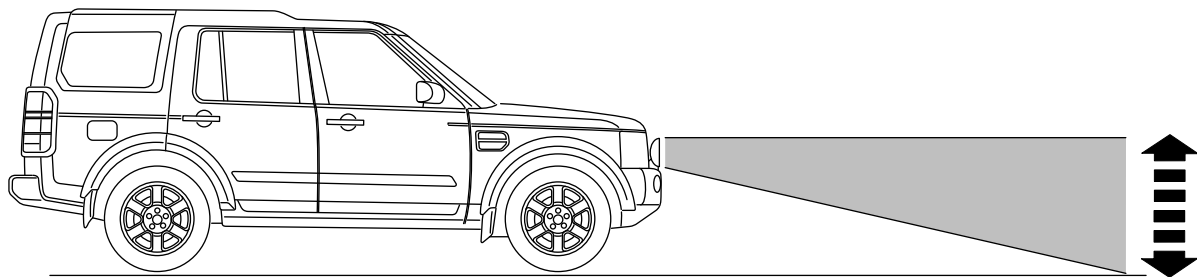



Other Data-Bus Private CAN-Bus Main High Speed CAN-Bus Main Medium Speed CAN-Bus Private Input LIN-Bus MOST Network (Optical) Output Refer to CAN Circuit

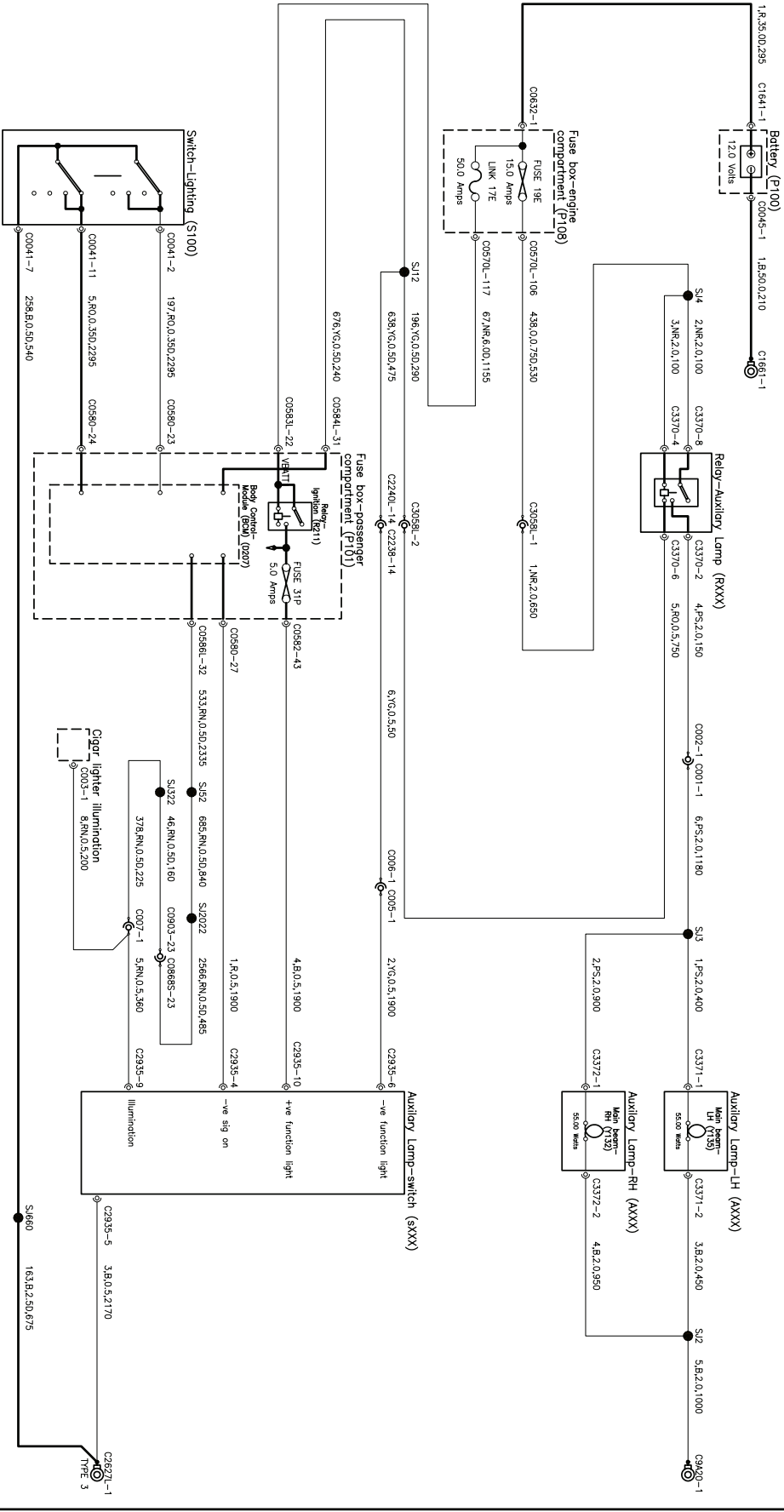

DOMAIN	AH00D	DATE	09-12-07	SYSTEM	AUXILIARY LIGHTING CIRCUIT	PROJCT	L319-10MY JOB#P90	DATE	11-20
APPROVED BY	SMW/TRE	DATE		SUB SYSTEM		DOMAIN	AH22-70060-L	ISSUE	01
APPROVED BY	SMW/TRE	DATE		WARRANT		SHEET	23-JUN-09		