



DEFENDER
VEHICLE RECOVERY GUIDE

Publication Part No. LRL 10 03 68 211

Vehicle Recovery Guide

INTRODUCTION

 **The vehicle recovery guide is designed to be used by qualified vehicle recovery personnel only.**

Disclaimers

The information contained within this recovery guide was correct at the time of print. In the interest of development, the right is reserved to change specifications, design, or equipment, at any time, without notice and without incurring any obligations. For the latest information, refer to:

<https://topix.landrover.jlrext.com>.

Appropriate service methods are essential for the safe and reliable recovery of all motor vehicles, as well as the safety of the person doing the work. The vehicle recovery guide provides general directions for safe and effective vehicle recovery.

Symbols used in this guide

 **Safety warnings indicate either a procedure which must be followed precisely, or information that should be considered with great care, in order to avoid the possibility of personal injury.**

 **Cautions indicate either a procedure which must be followed precisely, or information that should be considered with great care, in order to avoid the possibility of damage to the vehicle.**

All rights reserved. Published by © Jaguar Land Rover Limited 2020.

VEHICLE RECOVERY

Vehicle inspection process

To avoid any later disputes, before recovery of a vehicle, inspect the interior and exterior for damage. Make a record of any damage you find and advise the owner or driver accordingly. Even minor damage can be expensive to repair, so make sure you carefully examine all areas of the vehicle.

Vehicle recovery preparation

Wear clean gloves and fit suitable protective covers on the seat(s) and floor before driving the vehicle or operating the controls.

Recovery method

Transporter or trailer:

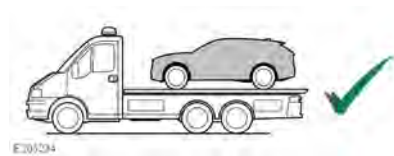

The recommended method for recovery or transportation of the vehicle is on a transporter or trailer designed for that purpose.

Straight bar tow on all wheels:



If the vehicle cannot be recovered by using the recommended method, in an emergency, the vehicle can be towed on all four wheels for a short distance.

- ❗ Do not tow the vehicle on all four wheels unless it is essential e.g., in an emergency.
- ❗ Do not tow the vehicle for more than 50 km (30 miles). Do not exceed 50 km/h (30 mph). Towing for a greater distance or at a higher speed may result in serious damage to the transmission.

Tow with front or rear wheels suspended:

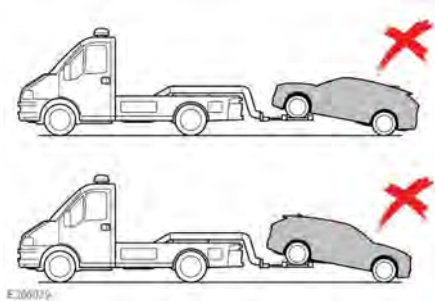

- ⚠ **Make sure that vehicle recovery or transportation is carried out by suitably qualified personnel and the vehicle is secured correctly.**
- ❗ Do not recover the vehicle with the front or rear wheels suspended. Where circumstance requires an exception can be made for 2 Wheel Drive (2WD) derivatives.
- ❗ The recovery agent must activate the transmission park release before recovery starts. Failure to activate the transmission park release can result in serious transmission damage.

- ❗ During vehicle recovery, the smart key must remain inside the vehicle and the ignition must be switched on. This is to make sure that the steering column is unlocked.
- ❗ The vehicle should not be towed on all four wheels and should not be recovered with the front or rear wheels suspended. Doing so can result in serious transmission damage.

Note: If the vehicle's battery is to be disconnected, the steering column must be unlocked first. The steering column cannot be unlocked with the battery disconnected.

Note: For vehicles with **Secure Tracker**, make sure that the owner is advised to place the vehicle in to **Transport Mode** using the **Land Rover InControl Remote Smartphone App**, or via the InControl website. Transport mode prevents stolen vehicle tracking alerts being raised while the vehicle is being transported.

Towing points

For access to the front towing eye, see **38, FRONT TOWING EYE**.

For access to the rear towing eye, see **39, REAR TOWING EYE**.

TRANSPORTING THE VEHICLE

- ⚠ **Use extreme caution when moving or towing the vehicle. Death or serious injury may occur.**
- ❗ Only use the lashing points or over-wheel lashings. Lashing over the body or suspension is not permissible, as settling of the suspension causes the lashing straps to slacken.

Vehicle Recovery Guide

- ❗ The vehicle should not be towed on all four wheels and should not be recovered with the front or rear wheels suspended. Doing so can result in serious transmission damage.

The recommended method for recovery or transportation of the vehicle, is on a transporter or trailer designed for that purpose.

ELECTRIC PARKING BRAKE (EPB) RELEASE

- ❗ **Check the wheels and make sure that all personnel are clear of the vehicle before carrying out the following procedure.**

If the Electric Parking Brake (EPB) does not release, because of a system fault or flat battery, for example, operate the emergency release procedure. Release the EPB, as follows:

Note: *The use of other methods such as starting aids, jump leads, and dollies may negate the need to perform this procedure.*

Deactivation

- Disconnect the vehicle battery.
- Raise and support the vehicle.

⚠ **Make sure to support the vehicle with axle stands.**

- Remove a rear wheel.
- Release the electrical connector.

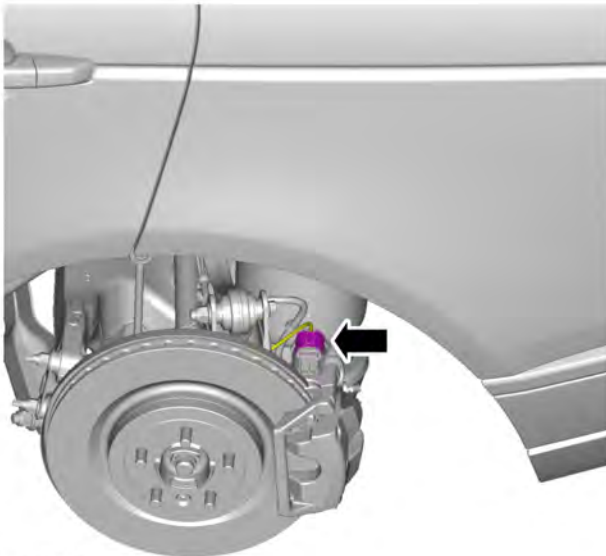

E146982

- Remove and discard the two bolts securing the EPB actuator to the brake caliper.

Torque: 11 Nm.

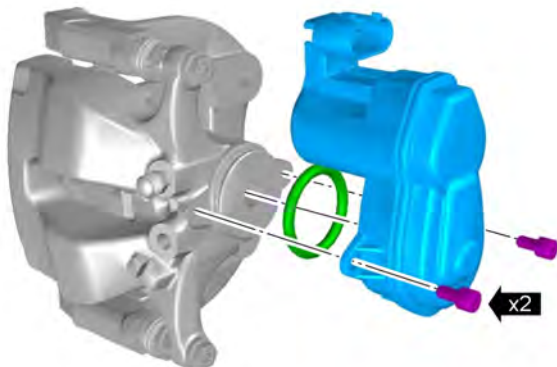

E146983

- Remove the EPB actuator from the brake caliper. Discard the O-ring seal.

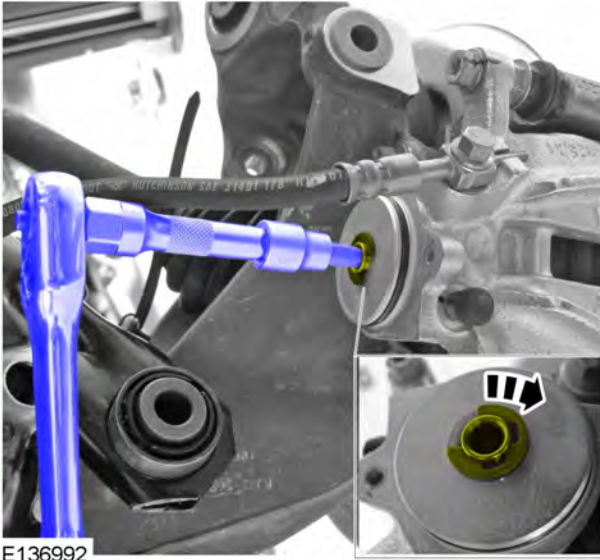

- Repeat the procedure for the other side of the vehicle.

Activation

- ❗ New O-ring seal is to be fitted.
- ❗ New bolts are to be fitted.
- To refit, reverse the removal procedure.
- Calibrate the EPB using the diagnostic tool. See **8, ON-BOARD DIAGNOSTICS (OBD) CONNECTOR LOCATION**.

TRANSMISSION PARK RELEASE

- ⚠ **Make sure that the vehicle is secured with wheel chocks. Apply the Electric Parking Brake (EPB), or have another person firmly press and hold the brake pedal. Failure to do so can result in unexpected movement of the vehicle, causing serious injury or death.**
- ❗ Failure to release the automatic transmission from Park (P) before recovering the vehicle, can result in serious damage to the automatic transmission.
- ❗ When vehicle recovery is complete, make sure to return the automatic transmission to P and refit the engine cover.

In the event that a vehicle with an automatic transmission needs to be recovered, it is essential that the transmission park release system is activated. This locks the automatic transmission in Neutral (N) and prevents the automatic transmission from automatically selecting P. The engine cover will need to be removed for access.

When the transmission park release system is activated, the automatic gear selector remains in P, but the automatic gear selector indicator and the instrument panel both display a flashing N.

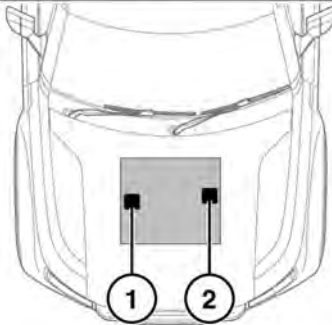

E255834

The transmission park release lever is located on the engine.

1. 3.0L petrol.
2. All engines, except 3.0L petrol.

Transmission park release lever operation

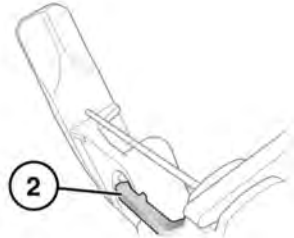
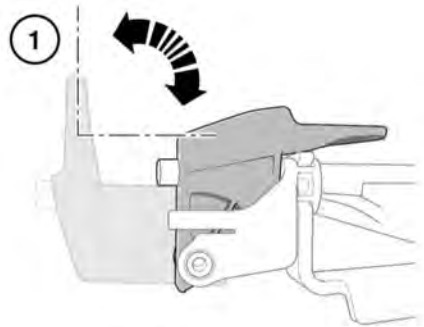

E167134

To release the automatic transmission from P:

1. Make sure the vehicle is suitably secured using an appropriate method e.g., wheel chocks. Gradually pull the lever up, approximately 90 degrees to the vertical position.

! Do not apply excessive force to the handle, and do not pull the handle up more than 90 degrees. Either action may damage the transmission park release system.

2. The securing latch engages to hold the handle in the vertical position.

Note: When the securing latch engages an audible click may be heard. Engagement may also be felt via the handle.

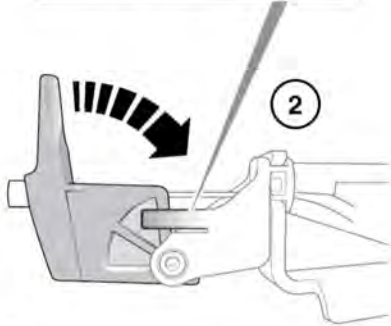

E167135

To return the automatic transmission to **P**:

1. Lightly release the securing latch.
2. The lever automatically returns to its normal, horizontal position.

Refit the engine cover.

ON-BOARD DIAGNOSTICS (OBD) CONNECTOR LOCATION

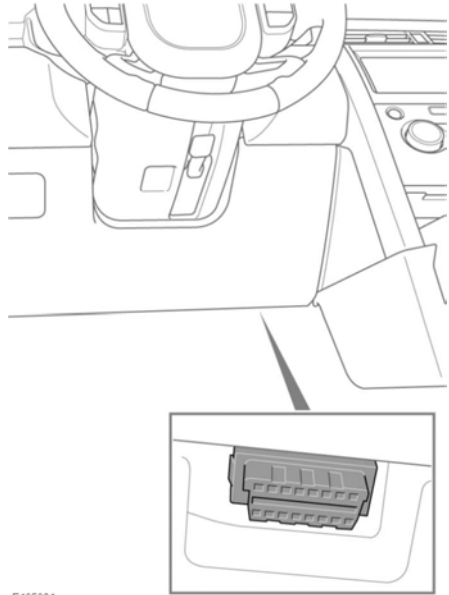

E195301

The On-Board Diagnostics (OBD) connector is located under the fascia, on the driver's side.

SMART KEY OPERATION

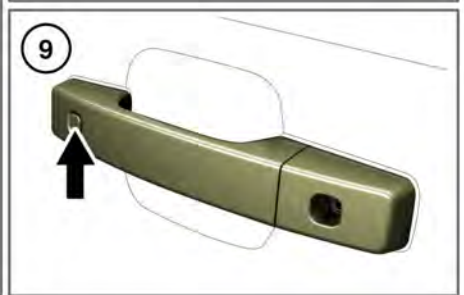
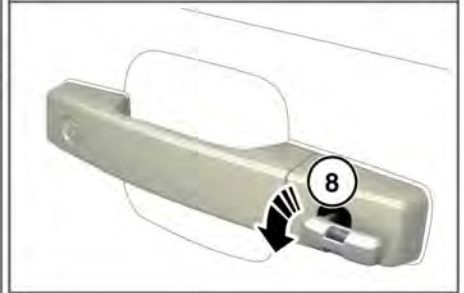

E261050

Vehicle Recovery Guide



The smart key system uses Radio Frequency (RF) transmissions that could interfere with implanted medical devices. To avoid any possibility of interference between the system and the device, make sure that the device is kept at a safe distance. The distance should be at least 22 cm (8 in) away from any transmitter. In rare circumstances, interference may cause an implanted medical device to malfunction. Malfunction of implanted medical devices may cause injury or death.

Note: For more information on the locations of the security system transmitters, see the Owner's Handbook.



Never leave children or animals unattended in the vehicle. The vehicle can be operated when the smart key is inside the vehicle. Doing so may potentially result in accident or unauthorised operation.

Note: The operational range of the smart key varies considerably, depending on atmospheric conditions and interference from other transmitting devices.

Note: If any door, or the taildoor, is unlocked ten times within a short period, the locking latch disables for approximately 1 minute.

Note: A replacement smart key can be obtained only from a retailer/authorised repairer. The retailer/authorised repairer will require proof of identification and ownership. Notify a retailer/authorised repairer immediately if a smart key is lost or stolen.

The vehicle is supplied with two smart keys. The smart keys act as remote controls for the locking and alarm system. The smart keys allow the vehicle to be locked, unlocked, and driven without the use of a conventional key. Each smart key also has an emergency key inserted in the smart key's body. See the Owner's Handbook.

Use of the smart key to operate the vehicle locks:

- 1. Lock:** Press to secure the vehicle. The vehicle locks. In some markets, a second press double locks the vehicle. If power-fold mirrors are enabled, the mirrors fold in. Press and hold to activate the global closing feature, if available. See the Owner's Handbook.
- 2. Unlock:** Press briefly to unlock the vehicle and disarm the alarm. The hazard warning lights flash twice to indicate that the vehicle is unlocked and the alarm is disarmed. The interior lights illuminate to assist entry to the vehicle. If power-fold mirrors are enabled, the mirrors unfold. See the Owner's Handbook.
- 3. Headlights:** When approaching the vehicle during darkness, press to switch on the headlights to provide approach illumination. Press again to switch approach illumination off. The approach illumination preset delay period is 30 seconds. The delay period can be configured to provide illumination lasting between 0 and 240 seconds. See the Owner's Handbook.

Note: Make sure the smart key is not left inside the vehicle before closing the taildoor. The smart key may not be detected if kept inside a metal container, or shielded by a device with a back-lit LCD screen. For example, a smartphone, laptop, including when inside a bag, or a games console. Also, if the vehicle is in an area of localised Radio Frequency (RF) interference, the smart key may not be detected. If the smart key is not detected inside the vehicle, the vehicle can still be locked. However, the vehicle does not automatically unlock. The vehicle unlocks only with another valid smart key.

4. Taildoor: Press briefly to unlock the taildoor. If the vehicle is locked and armed, all of the other doors remain closed and the exterior alarm remains armed while the taildoor is open. Press the lock button (1) to lock the taildoor when closed.
5. Panic alarm: Press and hold for 3 seconds, or press three times within 3 seconds, to activate the horn and the hazard warning lights. Once active for more than 5 seconds, the alarm can be cancelled. Press the button and hold for 3 seconds, or press three times within 3 seconds. The panic alarm also cancels if a valid smart key is present when the **START/STOP** button is pressed.
6. Emergency key blade: Push the release button.
7. Emergency key blade: Pull to withdraw the key blade.
8. Emergency unlock: Insert key blade into key barrel and rotate counter-clockwise to unlock door.

9. Keyless unlock: Press button on front of door handle to lock the vehicle.

ACTIVITY KEY

The activity key is a touchscreen with wrist strap designed to support situations where the smart key might be obtrusive or difficult to keep secure. The activity key is waterproof to a depth of 40 m and is shockproof. Care should be taken during certain sporting activities, e.g., skiing, jet-skiing, or diving, to protect the activity key.

The activity key provides full keyless entry and keyless start functionality. See the Owner's Handbook.

While the activity key is worn on the wrist, the smart key can remain inside the vehicle. When the activity key is activated, the vehicle locks, the alarm system arms, and any smart key remaining inside the vehicle is disabled.

Note: Make sure any smart keys left inside the vehicle are stored out of view.

Note: Locking preference settings are retained when locking or unlocking the vehicle using the activity key, e.g., single or double locking. See the Owner's Handbook.

Vehicle Recovery Guide

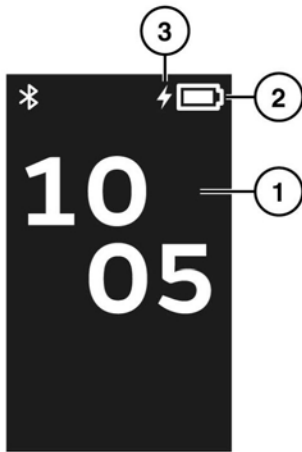

E257249

1. Home screen: Displays the time.
2. Battery charge status.

Note: If the battery charge level drops below 30%, the screen displays a prompt to charge the activity key.

Note: The screen disables if the charge level drops below 25%.

3. Charge icon: Displays when the activity key is being charged.

Note: Charge via the supplied magnetic USB cable. Replacements are available. Contact a retailer/authorised repairer.

Note: When left idle for a period of time, the activity key's touchscreen switches off to preserve battery power.

Touchscreen use:

1. Press and hold the screen for approximately 2 seconds to wake the home screen.
2. Swipe right to access the menu screen.

3. Touch the menu item required to select.

Locking:

1. Make sure the ignition is switched off.
2. Exit the vehicle, making sure that all of the doors and taildoor are closed.
3. Swipe the screen upward to access the **Locking** menu.
4. Touch the **Lock** icon.

Note: The hazard warning lights flash, and the power fold mirrors fold to confirm the locked status.

5. Touch the home icon to return to the home screen.

Unlocking:

1. Swipe the screen upward to access the **Locking** menu.
2. Touch the **Unlock** icon.

Setting the time:









- Select the **Settings** menu.
- Select the clock symbol and adjust the time using the up/down arrows.

Panic alarm: To sound the panic alarm, briefly touch the screen 3 times in quick succession.

Note: The panic alarm cannot be cancelled during the first 5 seconds of operation. Once this 5 seconds has passed, the panic function on the key will de-activate the panic alarm.

VEHICLE CHARGING SAFETY

Make sure to read and fully understand the following warnings and cautions before attempting to charge the vehicle. Failure to observe cautions and warnings may result in vehicle damage, injury, or death in the event of an accident.

-  Never disassemble, remove, or replace high voltage components, cables, or connectors. High voltage cables and connectors are coloured orange for identification purposes.
-  Never use a charging cable if there is any damage to the unit.
-  Never use an extension lead or multiple socket in order to extend the reach of a charging cable.
-  Never connect a plug adaptor to a charging cable when travelling abroad.
-  Always fully unwind the charging cable. Failure to fully unwind the charging cable could lead to overheating of the cable.
-  Before initially connecting a charging cable, make sure the electricity supply has been checked and approved by a suitably qualified person.
-  Never attempt to pull the cable from the charging port once it is locked. Damage to the cable's locking mechanism will result. If disconnection is required, press the unlock button on the smart key once for AC charging, twice for DC charging. The cable's locking mechanism re-engages after a short time.
-  Always select the correct charging cable for the vehicle when using a public charging station, with a connector that matches the vehicle's charging port.
-  Always contact a retailer/authorised repairer if the charging cable fails to release regularly.

Note: Before attempting to perform any repairs on a vehicle, consult a retailer/authorised repairer.

VEHICLE CHARGING OVERVIEW

-  Make sure all relevant safety warnings and cautions have been read and understood before charging the vehicle. See 12, VEHICLE CHARGING SAFETY.

A charging cable is supplied with the vehicle. The cable should be:

- Stored securely in the luggage compartment when not in use.
- Used if a public charging cable is not available.

Vehicle Recovery Guide

CHARGING PORT LOCATION

⚠ Make sure all relevant safety warnings and cautions have been read and understood before charging the vehicle. See 12, VEHICLE CHARGING SAFETY.



E267089

The charging ports are located as shown above.

Press the middle of the flap on the right side to gain access to the charging port. Once open, move the flap aside to gain access to the charging port.



E267090

For AC and DC charging:

1. Charging flap.
2. Charging indicator label.
3. Charging status lights. See 15, CHARGING PORT INDICATORS.
4. DC Charging port cap. For DC charging only.
5. Charging cable.
6. Charge flap catch.

CONNECTING A CHARGING CABLE

⚠ Make sure all relevant safety warnings and cautions have been read and understood before charging the vehicle. See 12, VEHICLE CHARGING SAFETY.

! Make sure to select the correct charging cable for the vehicle when using a public charging station. The vehicle supports both AC and DC charging providing the correct cable is used.

Note: Make sure that the AC charging cable meets standard IEC62196-2.

Note: Always connect the charging cable to the electricity supply before connecting to the vehicle. See 13, VEHICLE CHARGING OVERVIEW.

To connect a charging cable to the vehicle, first prepare the vehicle, and then connect the charging cable.

To prepare the vehicle:

1. Unlock the vehicle.
2. Make sure Park (P) is selected.
3. Make sure the vehicle's ignition is switched off.

4. Open the charging flap. If using the DC charge port, remove the cap. See **14, CHARGING PORT LOCATION.**

To connect the charging cable at home:

1. Plug in the domestic connector to the electricity supply.
2. Connect the charging cable to the appropriate vehicle charging port.

To connect the charging cable at a public charging facility:

1. Connect a public charging cable to the applicable vehicle charging port socket.
2. Follow the instructions on the charging post.

The charging cable is locked into position once connected.

The charging process starts automatically, if all conditions have been met. See **15, CHARGING PORT INDICATORS** and **17, CHARGING CABLE INDICATORS.**

When charging is complete, unplug and store the charging cable. See **18, DISCONNECTING A CHARGING CABLE.**

Note: During AC charging, if a power cut occurs, the charging process stops. Once power is restored, the AC charging process resumes automatically.

Note: If a power cut occurs during DC charging, the charging process must be manually resumed.

Note: A power cut may affect the vehicle's ability to fully charge before embarking on a journey.

Note: The vehicle is unable to start with the charging cable connected. See the Owner's Handbook.

CHARGING PORT INDICATORS



Make sure all relevant safety warnings and cautions have been read and understood before charging the vehicle. See **12, VEHICLE CHARGING SAFETY.**



A label adjacent to the charging port provides a quick reference to the behaviour of the charging indicator LED in relation to charging status. See the Owner's Handbook.

A charging status light next to the charging port illuminates to aid connecting the cable in dark conditions and to show the current charging status. The instrument panel also shows the charging status. Both are illuminated as follows:



A white flashing light indicates that a cable has been detected and the vehicle is attempting to start charging with an initialisation process. If the flashing white light is shown for longer than 10 seconds, check connections at both ends of the cable and check for any incomplete steps at the charge post. The instrument panel flashes a white cable symbol.



A blue pulsing light indicates that the initialisation process has been completed and timed charging has been set. The vehicle is not currently charging but will charge prior to the set departure time. The instrument panel flashes the clock symbol shown above. See the Owner's Handbook.



A green pulsing light indicates that the initialisation process has been completed and the vehicle is charging. The instrument panel flashes a green cable symbol.



A continuous green light indicates that the vehicle charging is completed. The instrument panel displays a green cable symbol.



A flashing red light indicates a charging fault with the vehicle. The instrument panel displays a red charging symbol. If the charging fault persists, contact a retailer/authorised repairer.

Charging status can also be viewed via the **MY EV** touchscreen menu. See the Owner's Handbook.

UNLOCKING THE CHARGING PORT

To unlock the charging port when the vehicle is locked:

1. When DC charging, press the unlock button on the smart key twice. If 2-stage unlocking is active, press the unlock button 3 times to unlock the charging port. See the Owner's Handbook.

Note: When AC charging, unlock the vehicle as normal, either using the smart key or keyless entry. See **9, SMART KEY OPERATION.**

2. Wait for the charging port lock to release. The charge port is unlocked when the status light displays continuous white or continuous green.
3. Remove the charging cable within 60 seconds.

Note: *If the cable is not released within 60 seconds, the charging port relocks.*

Note: *If the smart key's unlock button is pressed once during DC charging, the vehicle unlocks without disrupting the charging process or unlocking the charging port.*

Refer to the charging cable's emergency release procedure if the charging port does not release. See **18, CHARGING CABLE EMERGENCY RELEASE.**

CHARGING CABLE INDICATORS



Make sure all relevant safety warnings and cautions have been read and understood before charging the vehicle. See 12, VEHICLE CHARGING SAFETY.

The home charging cable contains four indicators to inform the user of its status.

Power	Charging	Temperature	Fault	Description
Off.	Off.	Off.	Off.	No electrical supply detected.
On.	Off.	Off.	Off.	Ready for operation.
On.	Flashing.	Off.	Off.	Charging in progress.
On.	On.	On.	On.	Self-test procedure in progress.
On.	Flashing.	On.	Off.	Slow charging due to increased temperature.
On.	Off.	On.	Off.	Charging inhibited due to temperature out of range. Protect cable and wallplug from excessive temperature and direct sunlight.
On.	Off.	Flashing.	Off.	Charging procedure interrupted. Check all connections.
Off.	Off.	Off.	Flashing.	Charging fault.
Off.	Off.	Off.	On.	The power supply to the vehicle has failed.

DISCONNECTING A CHARGING CABLE

 **Make sure all relevant safety warnings and cautions have been read and understood before charging the vehicle. See 12, VEHICLE CHARGING SAFETY.**

To disconnect a charging cable:

1. Make sure that the charging cable is unlocked from the charging port. See **16, UNLOCKING THE CHARGING PORT.**
2. If the charging cable is fitted with a release button, press the release button, and disconnect the charging cable from the vehicle.
Note: Always disconnect the charging cable from the vehicle first.
3. If DC charging, replace the DC charging port cap.
4. Fully close the charging flap.
5. If AC charging, remove the connector from the electricity supply.

CHARGING CABLE EMERGENCY RELEASE

 **Make sure all relevant safety warnings and cautions have been read and understood before charging the vehicle. See 12, VEHICLE CHARGING SAFETY.**

If the charging cable does not release, carry out the following:

1. Open the taildoor.
2. Locate the lower left-hand trim panel near the taildoor latch.
3. Pull the trim panel section to one side to access the emergency release ring.

4. Pull the emergency release ring to allow the charging cable to be removed from the charge port.

 If the charging cable cannot be removed following operation of the emergency release, consult a retailer/authorised repairer. Do not apply force or attempt to remove any components.

HYBRID SAFETY

WARNINGS FOR ELECTRIC AND HYBRID VEHICLES

In the event of a fault, damage, or fire affecting an electric or hybrid vehicle:

1. Always remember that the high voltage battery, subsystems, and components are energised and fully charged.
2. The high voltage battery, cables, and exposed electrical component pose a potential risk of electric shock.
3. The fumes from the ventilated and/or released high voltage battery are potentially toxic and inflammable.
4. Physical damage to the vehicle or to the high voltage battery may result in the immediate or delayed release of toxic and/or inflammable gases and in fire.

 **Never disassemble, remove, or replace high voltage components, cables, or connectors. Tampering with the high voltage system can cause severe burns or electric shock, which may potentially result in serious injury or death.**

The hybrid system has no serviceable parts. The high voltage cables and connectors are coloured orange for identification purposes. If maintenance or repair is required, always consult a retailer/ authorised repairer. Failure to do so, may affect the vehicle's warranty.

The hybrid system is insulated and protected with covers and shields. The result is that:

- The system is insulated from the vehicle.
- The system is protected from the environment.
- Access is prevented by unqualified personnel.

The vehicle monitors the integrity of the hybrid system. If a hybrid system fault is detected, the instrument panel displays a relevant warning message and may also illuminate a warning lamp. See the Owner's Handbook.

ENGINE START BACKUP

The engine start backup feature is required to disarm the alarm and start the engine if either of the following occur:

- The vehicle is unlocked using the emergency key blade.
- The smart key is not detected by the vehicle.

The engine start backup feature can only be used when the instrument panel displays **Place Smart Key as shown, and press start button**.

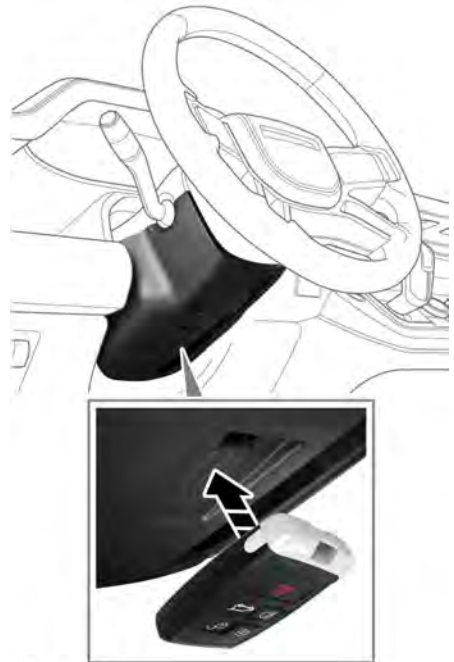

E246822

To carry out the engine start backup procedure:

1. Position the smart key flat against the side of the steering column.
Note: *There are markings on the steering column to help locate the correct position.*
2. While holding the smart key in position, firmly press the brake pedal.
3. Press and release the engine **START/ STOP** button.

Once the engine starts, release the brake pedal, if it is safe to do so.

If the smart key is not recognised, or the engine fails to start, consult a retailer/ authorised repairer.

INCONTROL REMOTE SMARTPHONE APP

Note: The availability and functionality of the **InControl Remote** smartphone app depends on the specification of the vehicle and the market in which the vehicle is being used.

Note: For further information, refer to the **InControl** section on the Land Rover website at: www.landrover.com/incontrol.

In order to use the **InControl Remote** smartphone app features, please complete the following steps:

1. Create an InControl account. See the Owner's Handbook.
2. Download the **InControl Remote** smartphone app to a smartphone. See the Owner's Handbook.

Available features within the **InControl Remote** smartphone app:

Vehicle Location

A map display of the vehicle's parked location and the user's current location.

Vehicle Status

Displays the latest status of vehicle alerts such as a low engine oil level. Each status gives an indication of the health of each alert, as well as offering advice on how to resolve any alerts.

Beep & Flash

Locates the vehicle by flashing the vehicle's lights and sounding an alert.

Note: The driver is responsible for complying with all regulations in force for a specific country, regarding the use of vehicle horns.

Vehicle Security

Displays the open and closed status of all the doors and windows, and the current alarm setting. **Vehicle Security** also displays the locked and unlocked status of the vehicle.

Vehicle Security allows the user to lock and unlock the vehicle remotely. If either lock or unlock cannot be performed, the phone screen displays an error message. When the vehicle is locked remotely, it is secured to the maximum possible level allowed in the market in which the vehicle was intended for original sale.

Note: If any window(s) is in an open position, the vehicle does not lock remotely, unless the window is closed. In some markets, remote closing of the windows is not permitted.

When the vehicle is unlocked remotely, it relocks after 40 seconds if no door or aperture is opened.

Regardless of which screen is currently displayed, if the vehicle's alarm is sounding, a pop-up screen is displayed with an option to reset the alarm.

Note: The driver is responsible for knowing the location of the vehicle and for making sure that the vehicle is secured.

Remote Climate

Remote Climate allows the engine of an automatic transmission vehicle to be started remotely, and to run for up to 30 minutes. The **Remote Climate** feature provides a comfortable temperature inside the cabin in advance of the driver entering the vehicle. Press the **engine start** icon on the **Remote Climate** section of the **InControl Remote** smartphone app. A target temperature can be set.

Remote Climate does not function if any of the following conditions exist:

- The vehicle's fuel level is low.
- The vehicle's battery charge level is low.
- The vehicle is not locked and alarmed.
- A window, door, bonnet, or the taildoor is open.
- The engine has been manually started.
- A system error occurs with a required vehicle system.
- A theft has been reported to the stolen vehicle monitoring centre.
- The vehicle's alarm is sounding.
- A crash event has been detected.
- The hazard warning lights are switched on.
- The automatic transmission is not in Park (P).
- The brake pedal or accelerator pedal is pressed.

Note: Some markets may prohibit the use of remote engine starting. The driver is responsible for knowing if this function can legally be used.

Note: **Remote Climate** is also available for vehicles fitted with a timed climate system. When the vehicle specification does not support remote engine starting, the timed climate system may be used to support cabin pre-conditioning. The condition also applies if the vehicle originated in a market with legal restrictions on remote engine starting.

Journeys

Displays the most recently completed journeys over 1 km in distance. Providing details of each journey from start to finish.

Note: The **Journeys** feature can be enabled or disabled via the **Vehicle Settings** section of the **InControl Remote** smartphone app, or on the My Land Rover InControl website at: <https://incontrol.landrover.com>.

Note: Stored journeys can be viewed, deleted, or exported as a .csv file to assist with business expenses.

Assistance

Displays vehicle information such as the VIN number. Direct calls can be made to the **Optimised Land Rover Assistance** call centre for breakdown assistance. In the event of a vehicle theft, direct calls can be made to the stolen vehicle tracking call centre, if **Secure Tracker** or **Secure Tracker Pro** is fitted.

Note: All calls are chargeable in accordance to mobile operator prices.

Vehicle Settings

Provides the user access to specific vehicle settings, service and transport modes, and journey preferences.

Note: Service and transport modes are only available for vehicles with **Secure Tracker** and **Secure Tracker Pro**.

SECURE TRACKER

Secure Tracker provide's a stolen vehicle tracking service. In the event that the vehicle has been tampered with, or moved without the owner's consent, the account owner is contacted by the InControl stolen vehicle tracking call centre. Alternatively, use the **InControl Remote** smartphone app or the phone number on the InControl website to contact the stolen vehicle tracking call centre.

Service Mode and **Transport Mode** can be enabled and disabled by using the **InControl Remote** smartphone app, or via the InControl website. Enabling and/or activating **Service** or **Transport Mode** prevents stolen vehicle tracking alerts being raised while the vehicle is being transported or serviced.

If the vehicle is being serviced or repaired, **Service Mode** must be enabled.

If the vehicle is being transported, **Transport Mode** must be enabled.

Note: The vehicle's alarm system is unaffected if **Transport Mode** is enabled.

Note: The vehicle's alarm system can be enabled or disabled if in **Transport Mode**, for one alarm cycle only. To disable the vehicle's alarm system from the touchscreen settings menu, select **Vehicle**. From the list, select **Security features**, followed by **Alarm Sensors**. See the Owner's Handbook.

Note: The owner is responsible for re-enabling or disabling **Service Mode** and **Transport Mode**. If the vehicle is in **Service Mode** or **Transport Mode** for a longer time period than originally set, the owner is required to re-enable the relevant **Service Mode** or **Transport Mode** option.

Note: The owner can select a pre-designated time period under 72 hours. The **InControl Remote** smartphone app allows for a maximum time period of 10 hours when selecting **Service Mode** or **Transport Mode**. The My InControl website allows for a maximum time period of 72 hours when selecting **Service Mode** or **Transport Mode**.

Note: For further information, please refer to the Land Rover website at: www.landrover.com/incontrol.

SECURE TRACKER PRO

Secure Tracker Pro includes all the features of **Secure Tracker**, and in addition, provides an enhanced level of security by integrating a secondary authentication between the smart key and the vehicle. An alert is generated to the stolen vehicle tracking centre if the owner's vehicle has been stolen without the authorised smart key(s).

Please refer to the secure tracker topic for further information. See **21, SECURE TRACKER**.

RUNNING OUT OF FUEL

 Avoid running out of fuel. Doing so can cause damage to the vehicle's engine, fuel, and emission control systems.

Note: If the vehicle does run out of fuel, seeking qualified assistance is advisable.

If the vehicle does run out of fuel, a minimum of 4.0 L is required to restart the engine. See **23, FUEL FILLER FLAP**.

The vehicle should be left with the ignition switched on for 5 minutes after refuelling, before attempting to restart the engine. The vehicle needs to be driven for a distance of 1.5 to 5 km in order to reset the engine management and monitoring systems.



E173721

Vehicles with a diesel engine may be supplied with an active misfuelling device. A metal flap is visible in the filler neck when the fuel filler cap is removed. Use the emergency funnel supplied with the vehicle to refill the fuel tank with a fuel can. Insert the funnel into the filler neck, fully and squarely, to open the active misfuelling device. See **25, ACTIVE DIESEL MISFUELLING PROTECTION DEVICE**.

Note: Misfuelling devices are dependent on the market specification.

FUEL FILLER FLAP



Make sure the relevant safety warnings have been read and understood before refuelling the vehicle. See the Owner's Handbook.

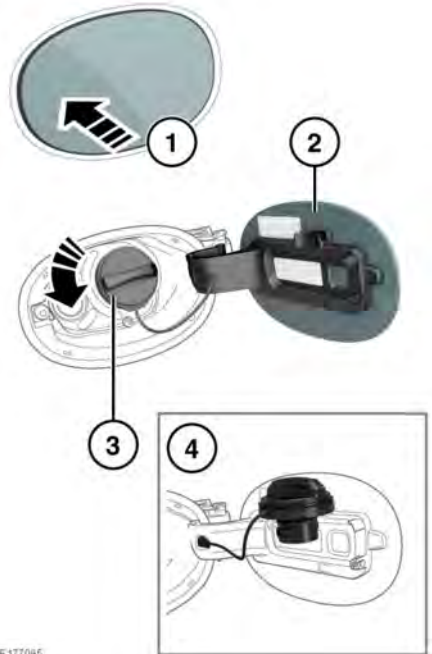

E177085

The fuel filler flap is located on the right side of the vehicle, at the rear. To operate, proceed as follows:

1. Press and release the rear of the fuel filler flap to unlatch.
2. Pull the flap open. The label on the inside of the flap indicates the correct fuel for the vehicle.
3. Turn the filler cap counter-clockwise to undo.

Vehicle Recovery Guide

4. Use the securing clip to keep the filler cap out of the way while fuelling.

When replacing the filler cap, turn it clockwise until the ratchet clicks.

To close the filler flap, push the flap until it is securely latched.

Plug-in Hybrid Electric Vehicles (PHEV) also incorporate a locking fuel filler flap. See **24, FUEL FILLER FLAP LOCK**.

FUEL FILLER FLAP LOCK

Note: Make sure that the vehicle is refuelled shortly after the refuelling button is pressed. Failure to do so may result in the fuel tank not being filled to the required level. If in doubt, check the fuel level gauge in the instrument panel before continuing the journey, to prevent running out of fuel.

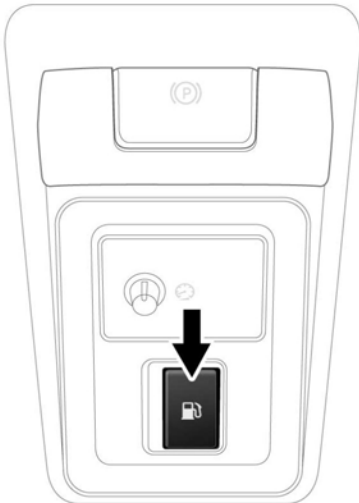

E250213

To enable refuelling, carry out the following:

1. Switch off the vehicle's ignition, apply the Electric Parking Brake (EPB), and make sure that the transmission is engaged in Park (P).
2. Press the refuelling button located in the lower switch panel at the driver's side of the fascia. The isolation valve on the fuel tank opens to equalize the fuel tank pressure. The fuel filler flap unlocks. The instrument panel displays a message to confirm that the fuel filler flap is unlocking.
3. The instrument panel displays a message to confirm that the fuel filler flap is unlocked and the vehicle can be refuelled. See **23, FUEL FILLER FLAP**.

The isolation valve on the fuel tank remains open for approximately 10 minutes, at which point the valve shuts, preventing further refuelling. If further refuelling is required, repeat the above process from step 2 to open the isolation valve on the fuel tank.

Note: Make sure that the vehicle is stationary. The fuel filler flap does not unlock, and the isolation valve on the fuel tank does not open, if the vehicle is moving. The instrument panel displays a message to confirm that the vehicle's speed is too high.

Note: Make sure that the fuel filler flap is closed after refuelling. The instrument panel displays a message to confirm that the fuel filler flap is not fully closed.

If a fault is detected on either the fuel filler flap system, or on the isolation valve system on the fuel tank, the instrument panel displays a message. In this event, consult a retailer/authorised repairer or roadside assistance. See the Owner's Handbook. See **20, INCONTROL REMOTE SMARTPHONE APP**.

FUEL FILLER

⚠ Make sure the relevant safety warnings have been read and understood before refuelling the vehicle. See the Owner's Handbook.

! Check the fuel pump information carefully to make sure that the correct fuel is used to refuel the vehicle. Inadequate fuel can reduce engine performance and may cause permanent damage to engine components.

! If the vehicle is filled with the incorrect fuel, it is essential to seek qualified assistance before starting the engine. Inadequate fuel can reduce engine performance and may cause permanent damage to engine components.

Filling station pumps are equipped with automatic cut-off sensing, to avoid fuel spillage. Fill the tank until the filler nozzle automatically cuts off the supply. Do not attempt to fill the tank beyond this point.

Note: Filling station pumps used for commercial vehicles deliver fuel at a higher rate than normal. The higher fill rate can cause premature cut-off and may cause fuel spillage. Only the use of standard light vehicle fuel pumps is recommended.

ACTIVE DIESEL MISFUELLING PROTECTION DEVICE

! Do not force an incorrectly sized fuel pump nozzle into the filler neck. Forcing an incorrectly sized fuel pump nozzle into the filler neck may result in damage to the vehicle.



E170483

Vehicles with a diesel engine may have an active misfuelling protection device. A metal flap is visible in the filler neck when the fuel filler cap is removed. The active misfuelling protection device helps to prevent the fuel tank from being filled with the incorrect fuel, e.g., petrol. Refuelling is permitted if a correctly sized, diesel fuel pump's filler nozzle is inserted, fully and squarely, into the vehicle's fuel filler neck, as illustrated.

Note: To refuel with a fuel can, use the emergency funnel supplied with the vehicle. See **22, RUNNING OUT OF FUEL**.

Note: Misfuelling devices are dependent on the market specification.

Vehicle Recovery Guide

OPENING THE BONNET

- ⚠** Before opening the bonnet, make sure that the ignition is switched off and the smart key is removed from the vehicle. Failure to do so can potentially result in serious injury or death.

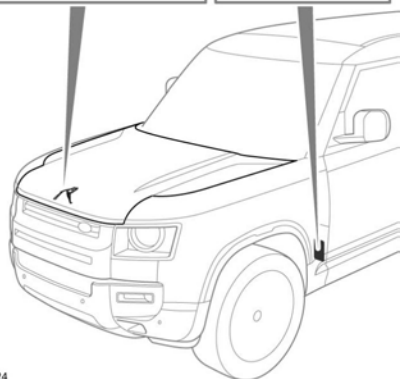
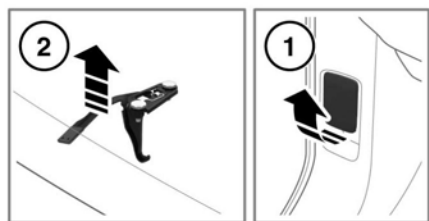

- E249324
1. Pull the handle, located in the driver's side front footwell.
 2. Lift the bonnet safety catch, located underneath the centre of the bonnet. Raise the bonnet.

CLOSING THE BONNET

- ⚠** Before closing the bonnet, make sure that no-one is obstructing the closing area and that hands and clothes are clear. The closing bonnet may cause serious injuries.

- ⚠** Do not drive with the bonnet secured by the safety catch alone. If the bonnet opens while driving, it may lead to a collision, which may cause serious injuries or death.

- ⚠** When closing the bonnet, make sure to stand in front of the vehicle. Do not attempt to close the bonnet while standing at the side of the vehicle. Doing so may result in incorrect latching of the bonnet, which may cause serious injuries or death.

To close the bonnet:

1. Using both hands, lower the bonnet and let it drop from a height of between 20 to 50 cm.
2. Try to lift the front edge of the bonnet, near both corners, to check that it is securely engaged.
3. If the bonnet lifts slightly, it is not properly latched. Open the bonnet again, and with a little more force, try again to close it.

FLUID FILLER LOCATIONS

- ⚠** Do not start the engine, or drive the vehicle, if leaked fluid could possibly make contact with a hot surface. Any leaked fluid coming into contact with a hot surface, such as the exhaust, could result in combustion. Seek qualified assistance immediately.

- ⚠** Always observe and follow the safety precautions when working in the engine compartment. Failure to do so may result in serious injury or death.

Note: Further information on safety precautions can be found in the relevant section of the Owner's Handbook. See the Owner's Handbook.

Note: The brake fluid reservoir is always located on the driver's side.

A number of simple checks and routine maintenance must be carried out at regular intervals. See the Owner's Handbook.

2.0L petrol engine

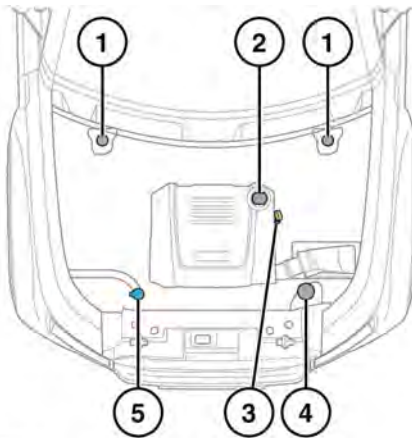

E249205

1. Brake fluid reservoir cap.
2. Engine oil filler cap.
3. Engine oil level dipstick.
4. Engine coolant reservoir filler cap.
5. Washer fluid reservoir filler cap.

3.0L in-line 6 cylinder petrol engine

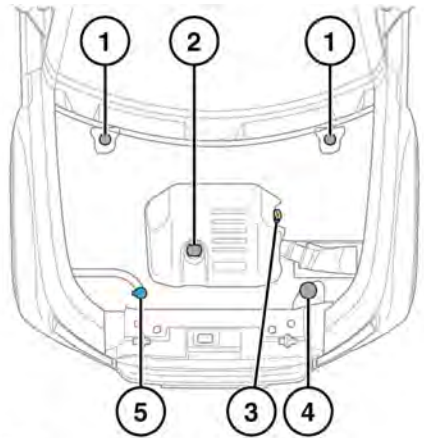

E249206

1. Brake fluid reservoir cap.
2. Engine oil filler cap.
3. Engine oil level dipstick.
4. Engine coolant reservoir filler cap.
5. Washer fluid reservoir filler cap.

2.0L diesel engine

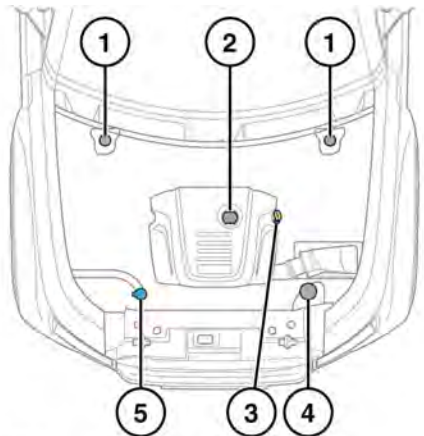

E249204

Vehicle Recovery Guide

1. Brake fluid reservoir cap.
2. Engine oil filler cap.
3. Engine oil level dipstick.
4. Engine coolant reservoir filler cap.
5. Washer fluid reservoir filler cap.

3.0L diesel engine

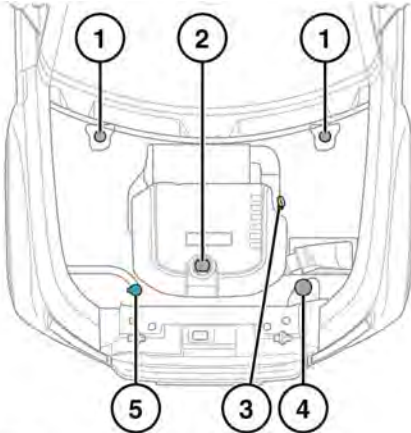

E268900

1. Brake fluid reservoir cap.
2. Engine oil filler cap.
3. Engine oil level dipstick.
4. Engine coolant reservoir filler cap.
5. Washer fluid reservoir filler cap.

Vehicles with Diesel Exhaust Fluid (DEF)

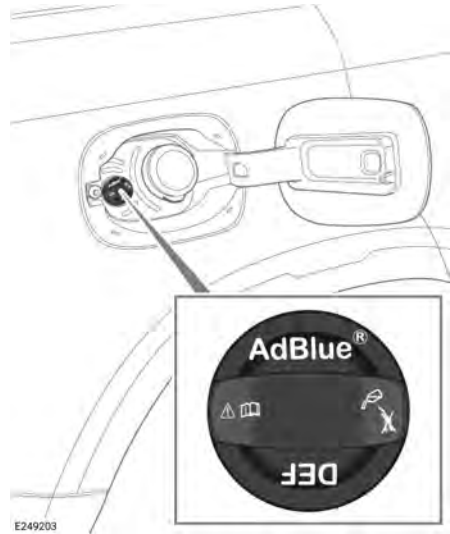

E249203

The Diesel Exhaust Fluid (DEF) tank filler cap is located inside the fuel filler flap, to the side of the fuel filler cap. See the Owner's Handbook.

CONNECTING JUMP LEADS

⚠ Remove all metal jewellery before working on, or near, a battery or boost terminals. Never allow metal objects or vehicle components to come into contact with the battery or boost terminals. Metal objects can cause sparks or short circuits, potentially resulting in an explosion.

⚠ Do not allow the battery posts or terminals to come into contact with skin. Battery posts and terminals contain lead and lead compounds, which are toxic. Always wash hands thoroughly after handling the battery.

 Do not expose any battery to an open flame or spark, as the battery produces explosive, flammable gas.

 Do not connect the jump leads to any battery terminal on the vehicle. Doing so can cause a spark, which can result in an explosion. Doing so will also result in damage to the charging system.

 Never jump start (boost), charge, or try to start a vehicle with a frozen battery. Doing so can result in an explosion.

 Rotating parts of the engine can cause serious injury. Take extreme care when working near rotating parts of the engine.

 Before attempting to start the vehicle, make sure that the Electric Parking Brake (EPB) is applied, or suitably chock the wheels. Make sure that Park (P) is selected. Failure to do so may result in accidents causing serious injury or death.

 Suitable eye protection must be worn when working in the area of a battery. Battery acid can cause serious injury to eyes.

 During normal use, batteries emit explosive gas sufficient to cause severe explosions and capable of causing serious injury. Keep sparks and open flames away from the battery.

 Make sure there is no physical contact between the donor and disabled vehicles, other than the jump leads. Failure to do so may cause damage to the vehicle.

 Make sure that any battery or starting aid is a 12-volt device. Unapproved devices can cause damage to the vehicle.

 Disconnect the jump leads before operating any electrical equipment. Failure to do so may cause damage to the vehicle.

Note: Before connecting the jump leads to the disabled vehicle's boost point terminals, make sure the donor vehicle's boost point connections are correct. Also make sure that all electrical equipment has been switched off.

Vehicle Recovery Guide

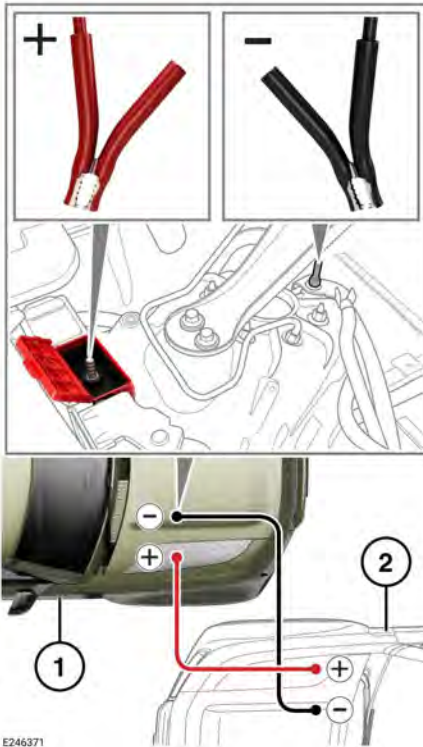

1. Disabled vehicle.
2. Donor vehicle.

To connect the jump leads:

1. Connect the positive (red) jump lead to the recommended positive (+) boost point terminal on the donor vehicle.
Note: Refer to the donor vehicle's Owner's Handbook for the recommended positive boost terminal.
2. Connect the other end of the positive (red) jump lead to the positive (+) boost point terminal on the disabled vehicle, as illustrated.

3. Connect the negative (black) jump lead to the recommended negative (-) boost point terminal on the donor vehicle.

Note: Refer to the donor vehicle's Owner's Handbook for the recommended negative boost terminal.

4. Connect the other end of the negative (black) jump lead to the negative (-) boost point terminal on the disabled vehicle, as illustrated.

Note: Check that all cables are clear of any moving components. Make sure that all four connections are secure.

5. Start the engine of the donor vehicle. Allow the engine to idle for a few minutes.
6. Start the engine on the disabled vehicle.

Note: Do not switch on any electrical circuits on the disabled vehicle until after the jump leads are removed.

7. Allow both vehicles to idle for 2 minutes.
8. Switch off the donor vehicle.
9. Disconnect the negative (black) jump lead from the previously disabled vehicle.
10. Disconnect the negative (black) jump lead from the donor vehicle.
11. Disconnect the positive (red) jump lead from the previously disabled vehicle.
12. Disconnect the positive (red) jump lead from the donor vehicle.

CONNECTING A STARTING AID

To start the vehicle using a starting aid, or a slave battery, carry out the following:

1. Connect the positive (red) jump lead to the vehicle's positive (+) boost point terminal.
2. Connect the negative (black) jump lead to the vehicle's negative (-) boost point terminal.
3. Switch on the starting aid.
4. Start the engine. Allow the engine to idle.
5. Disconnect the negative (black) jump lead from the vehicle's boost point terminal.
6. Switch off the starting aid.
7. Disconnect the positive (red) jump lead from the vehicle's boost point terminal.

FUSE BOX LOCATIONS

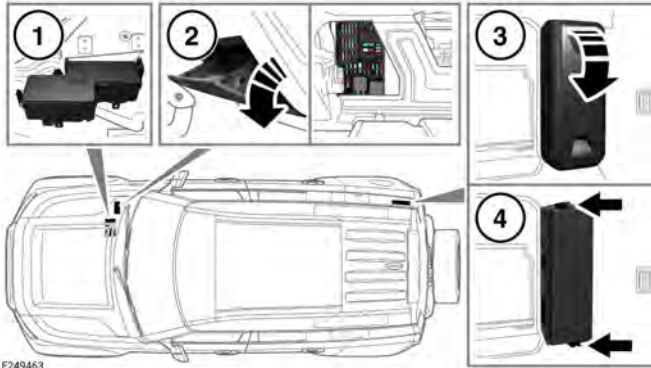

E249463

- !** Take care to protect the box from moisture. Refit the fuse box lid at the earliest opportunity.

Access the fuses as follows:

1. Engine compartment fuse box:
Remove the under-bonnet cover. See the Owner's Handbook. Release the four clips to remove the fuse box lid.
Note: The fuse box is always located on the passenger's side of the vehicle.
2. Passenger compartment fuse box:
Open the glovebox. See the Owner's Handbook. Firmly press the top of the support stay at each end and lower the glovebox into the footwell.
Note: The fuse box label for the passenger compartment fuse box is contained within the load space fuse box.
3. Loadspace fuse box cover: Pull the fuse box cover forwards to release the six clips.
4. Loadspace fuse box: Release the two clips to remove the fuse box lid.

TOOL KIT

- !** Make sure the relevant safety warnings have been read and understood before using the tool kit. See the Owner's Handbook.



E246857

The tool kit is located beneath the loadspace floor panel.

The tool kit consists of the following:

1. Jack assembly.
2. Locking wheel nut adaptor.

3. Spare wheel alignment tool.



E246858

The jack assembly consists of:

1. Jack: Observe the instructions printed on the jack.
2. Wheel brace.
3. Jack handle.

Note: Tool types and positions may vary from the illustration.

Note: Examine the jack occasionally. Clean and grease the moving parts, particularly the screw thread, to prevent corrosion.

Note: Take careful note of the storage position for each tool, as it is important to return the tools to their correct position after use.

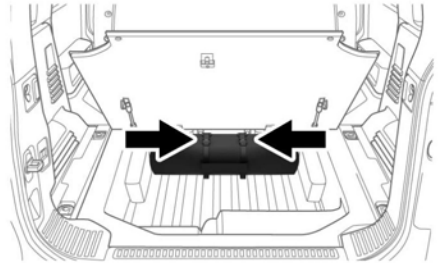
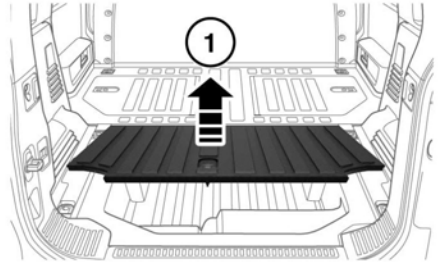

E268890

Commercial vehicles: The tool kit is stored in a bag, and secured in the storage compartment under loadspace floor, with 2 straps.

REMOVING THE SPARE WHEEL

Make sure to read and fully understand the following warnings. Failure to comply with the safety instructions may result in an accident, leading to serious injury or death.



Make sure the relevant safety warnings have been read and understood before removing the spare wheel. See the Owner's Handbook.

Vehicle Recovery Guide

 An open taildoor obscures the rear lights. If available, place a warning triangle at a suitable distance behind the vehicle, facing toward oncoming traffic. See the Owner's Handbook.

 Do not store the wheel while the vehicle is raised on the jack.

 Always secure the spare wheel, or the removed wheel, in the correct position, using the three wheel nuts.

Note: If in any doubt regarding the ability to remove or secure the spare wheel, see the Owner's Handbook.

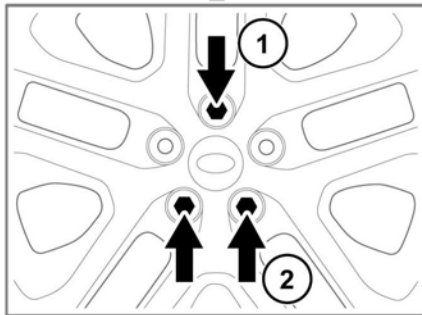

E246859

The spare wheel is located on the taildoor. The spare wheel is secured to the vehicle with three wheel nuts.

The location of the locking wheel nuts depends on the specification of the vehicle:

1. Steel wheels: One locking wheel nut in the upper position, as shown.
2. Alloy wheels: Two locking wheel nuts in the lower positions, as shown.



E259529

Vehicles with steel wheels have a hubcap. To remove the hubcap:

1. Insert a suitable tool into the slot on the hub cap.
2. Carefully lever the hub cap off the wheel nuts.

To remove the spare wheel:

1. Carefully remove the spare wheel's cover or hubcap.

2. Use the locking wheel nut adaptor and the wheel brace to remove the locking wheel nuts. See the Owner's Handbook.
3. Remove the standard wheel nuts.

⚠ Make sure that the spare wheel is supported when removing the final wheel nut. Failure to do so may result in serious injury or death.

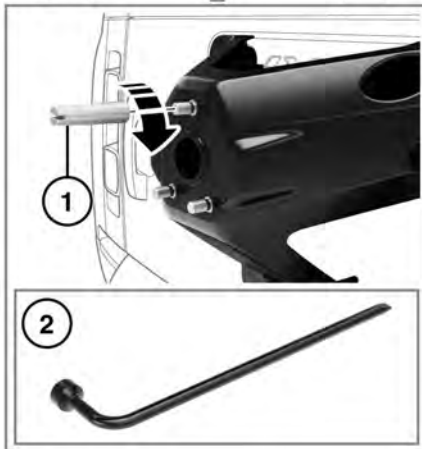

E253061

Vehicles with alloy wheels: A spare wheel alignment tool is supplied in the vehicle's tool kit. See the Owner's Handbook.

Install the spare wheel alignment tool as shown before storing the spare wheel on the vehicle:

1. Fit the spare wheel alignment tool to the spare wheel carrier.
2. Tighten the spare wheel alignment tool using the end of the wheel brace.

⚠ Make sure that the locking wheel nuts are fitted in the correct location.

Reverse the removal procedure to store the changed wheel. Tighten the spare wheel nuts to 140 Nm.



E259530

⚠ Make sure that the hubcap is correctly aligned to the locking wheel nut.





To install the hubcap:

Vehicle Recovery Guide

1. Align the hubcap to the locking wheel nut.
2. Press the hubcap firmly into place.

WHEEL CHANGING

Make sure to read and fully understand the following warnings. Failure to comply with the safety instructions could result in an accident, leading to serious injury or death.

-  **Make sure the relevant safety warnings have been read and understood before changing a wheel. See the Owner's Handbook.**
-  **Disconnect any trailer or caravan from the vehicle.**
-  **The standard vehicle jacking points should be used to raise the vehicle. Do not raise the vehicle by jacking under the fixed side steps, deployable side steps, or side tubes.**
-  Only jack the vehicle using the jacking points described, or damage to the vehicle could occur.

Note: To allow easier access to the vehicle's jacking points, it is recommended that the deployable side steps are in the stored position. See the Owner's Handbook.

Note: Vehicles fitted with deployable side steps: Select off-road height before jacking the vehicle. See the Owner's Handbook.

Note: A tilt sensor activates the alarm if the vehicle is tilted in any direction after it has been locked. To lock the doors while changing the wheel, and avoid the alarm activating, the tilt sensor can be temporarily disabled. See the Owner's Handbook.

Before raising the vehicle:

1. Remove the required tools from the vehicle. See the Owner's Handbook.
2. Remove the spare wheel. See **33, REMOVING THE SPARE WHEEL.**
3. Correctly position the wheel chocks. See the Owner's Handbook.



E259529

Vehicles with steel wheels have a hubcap. To remove the hubcap:

1. Insert a suitable tool into the slot on the hub cap.
2. Carefully lever the hub cap off the wheel nuts.

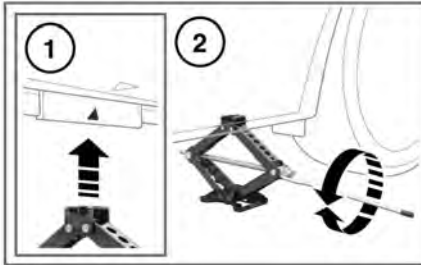

E246861

To change a wheel:

1. Use the wheel nut brace to loosen the wheel nuts of the wheel to be replaced. Turn half a turn counter-clockwise.
2. Locate the jack under the relevant jacking point (1).

! Do not allow the jack to contact the sill at any other point, as damage may result.

3. Unfold the handle from the stored position on the jack. Fit the wheel nut brace to the end of the cranking handle.
4. Rotate the handle clockwise (2) to raise the jack, until the jack pin locates into the jacking point.

5. Raise the vehicle until the wheel is clear of the ground.

! **Avoid rapid, jerky actions. Rapid, jerky actions may cause the vehicle and jack to become unstable, which may result in an accident, leading to serious injury or death.**

6. Remove the wheel nuts. Place the wheel nuts together where they cannot roll away.

7. Remove the wheel and place it to one side.

! Do not lay the wheel on its face, as this may damage the finish.

8. Fit the spare wheel to the hub.

9. Refit the wheel nuts. Lightly tighten the wheel nuts. Make sure the wheel is making contact with the hub evenly.

10. Make sure the area under the vehicle is clear of obstructions. Lower the vehicle slowly and smoothly.

11. With all of the wheels on the ground and the jack removed, fully tighten the wheel nuts. Tighten the wheel nuts, in the sequence shown in the illustration, to the correct torque of 140 Nm.

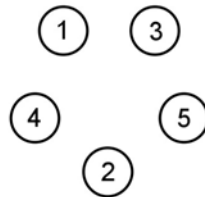

E132675

Note: If it is not possible to torque the wheel nuts when a wheel is replaced, set to the correct torque as soon as possible.

Vehicle Recovery Guide

Check and adjust the tyre pressure as soon as possible.

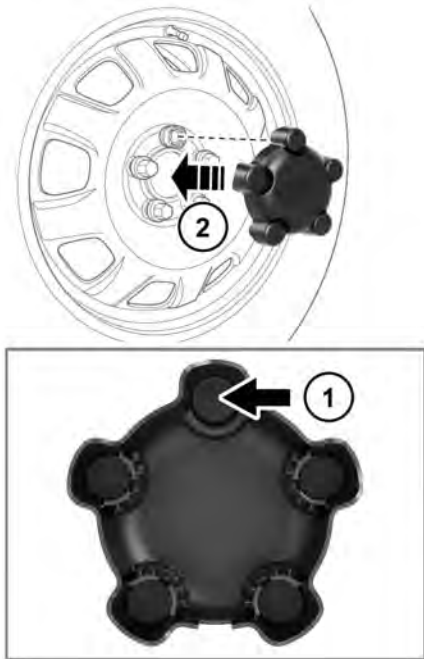

E259530

- ⚠ Make sure that the hubcap is correctly aligned to the locking wheel nut.

To install the hubcap:

1. Align the hubcap to the locking wheel nut.
2. Press the hubcap firmly into place.

FRONT TOWING EYE

⚠ The front towing eye is designed for both on-road and off-road recovery (up to 6.5 tonnes). If the towing eye is used for any other purpose, it may result in vehicle damage and can cause serious injury or death.

⚠ Use extreme caution when moving or towing the vehicle. Death or serious injury may occur.

⚠ Remove the front towing eye cover before driving off-road, to prevent damage or loss. The cover must be replaced before driving on the road.

The front towing eye is located behind a removable cover in the front bumper.

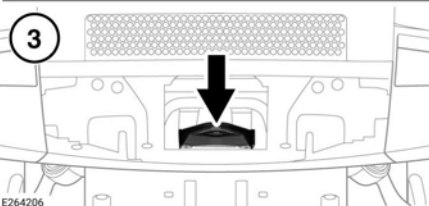
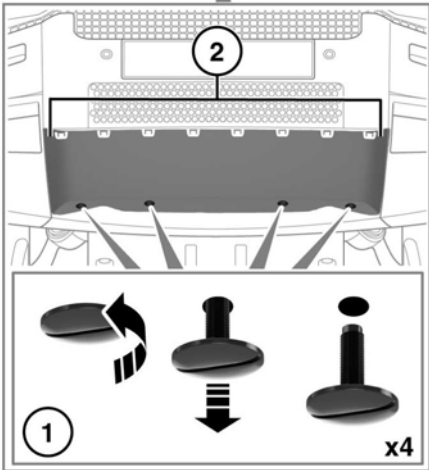
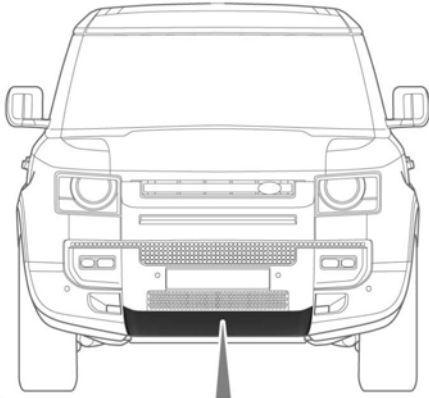

E264206

2. Pull the cover forward from the rear lower edge to release the lower tabs and the lugs on the top edge of the cover.
3. The towing eye is located in the centre of the exposed area.

To refit the cover:

1. Offer up the cover. Make sure the lugs at the top edge and the tabs in the bottom edge engage with the holes in the bumper.
2. Rotate each of the fasteners clockwise to secure the cover in position.

REAR TOWING EYE



The screw-in type rear recovery eyes are designed for on-road recovery only. If the screw-in type towing eyes are used for any other purpose, it may result in vehicle damage and can cause serious injury or death.



Use extreme caution when moving or towing the vehicle. Death or serious injury may occur.

Note: The rear towing eyes may be used to tow another vehicle, if required.

To remove the cover:

1. Rotate each of the fasteners counter-clockwise with a suitable tool.

Vehicle Recovery Guide

Vehicles without exposed towing eyes

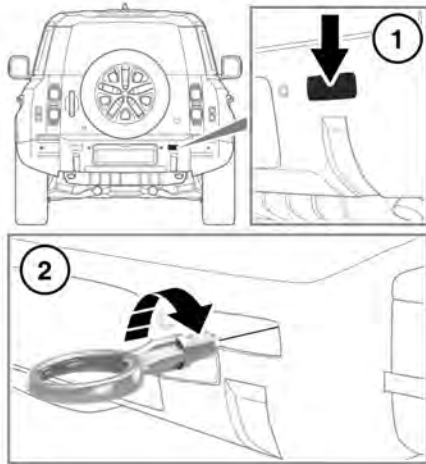

E246418

The vehicle's rear towing eye socket is located behind the rear bumper cover **1**. To remove the cover, lever the left-hand side of the cover outward from the bumper.

The vehicle's rear towing eye **2** is located underneath the loadspace floor. Screw the towing eye into the aperture located behind the rear bumper cover.

To refit the cover, push the right-hand side of the cover home first. Then push the left-hand side of the cover to be flush with the bumper.

Vehicles with exposed towing eyes



The rear exposed towing eyes are designed for both on-road and off-road recovery (up to 6.5 tonnes). If the exposed towing eyes are used for any other purpose, it may result in vehicle damage and can cause serious injury or death.



E249092



Avoid leaving towing equipment attached to the rear towing eyes when not in use. Some towing equipment may damage the vehicle's paintwork.

Vehicles with exposed towing eyes have a pair of towing eyes protruding through the rear bumper cover **1**.

LABEL LOCATIONS



Warning labels attached to the vehicle bearing this symbol mean: Do not touch or adjust components until having read the relevant instructions in the handbook.



Labels showing this symbol indicate that the ignition system utilises very high voltages. Do not touch any ignition components while the ignition is switched on.

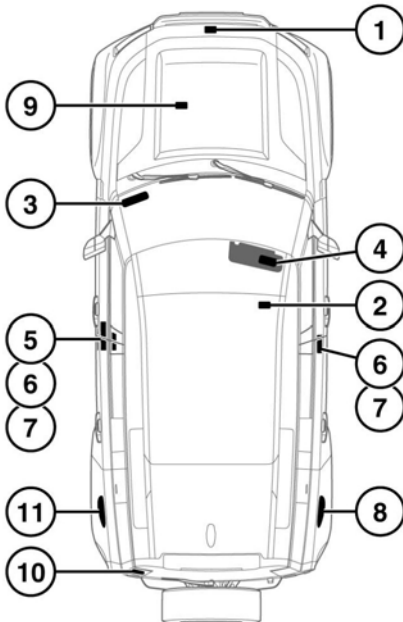

E267874

1. Bonnet locking platform: Air Conditioning (A/C) label.
2. Top of the battery: Battery warning symbols.

3. The Vehicle Identification Number (VIN) is etched onto a label, visible through the lowest part of the left side of the windscreen. The number is also stamped into the right-side suspension tower.

Note: The VIN number may be requested by the retailer/authorised repairer.

4. Passenger side sun visor: Airbag label, vehicle handling label.
5. B pillar: VIN certification label, containing the certified vehicle weights.
6. B pillar or inside base of the front door: Tyre pressure labels.
7. B pillar: Airbag warning label.
8. Inside the fuel filler flap: Fuel label.
9. Engine number: Inlet manifold.
10. Rear taildoor warning information.
11. PHEV information and warning label (PHEV vehicles only): Located inside charge flap.

It is important to be familiar with these subjects, to make sure that the vehicle and its features are used safely.

